

INICIO

MÉDIA A

MÉDIA B

MÉDIA C

5º Enduro Amigos na Trilha
14/07/2018



IMPORTANTE

PLANILHA TERMICA
FITA ADESIVA DO LADO DE
TRÁS. NÃO USE CANETA
MARCA TEXTO,
USE CANETA ESFEROGRÁFICA
OU HIDROGRÁFICA

DIRETORES DE PROVA:
DIOGES OSELLAME
DIONATAN OSELLAME

REALIZAÇÃO:
EQUIPE AMIGOS NA TRILHA

NOS TRECHOS URBANOS
PREVALECEM AS LEIS DO
CÓDIGO NACIONAL DE
TRANSITO. É OBRIGAÇÃO
RESPEITAR AS PROPRIEDADES
ALHEIAS E OS MORADORES.
A ORGANIZAÇÃO NÃO SE
RESPONSABILIZA POR PASSAR
PROGRAMAÇÃO DE NAVEGAÇÃO.
É OBRIGAÇÃO DO PILOTO
CONFERIR A PROGRAMAÇÃO DO
NAVEGADOR.

LARGADA - 14:00 HS
CTG TIO MILLO
NEUTRO PRINCIPAL RANCHO DO
CAVALO VELHO - SIDEROPOLIS
CHEGADA NO MESMO
LOCAL DA LARGADA

1 ETAPA KM 40,79
2 ETAPA KM 31,37
TOTAL KM 72,16

LEVANTAMENTO DA PROVA
COM MOTO CRF 230F COM
PNEU DIANTEIRO BOM
E 12 LIBRAS

14/07/2018

Pág: 001



CUIDADO



ATENÇÃO



MUITA ATENÇÃO

Tempo de Prova

MÉDIA A 02:59:50

MÉDIA B 03:01:32

MÉDIA C 03:05:18



AFERIÇÃO

Aferição

0.00		1	AFER
0.25		2	AFER
0.36		3	AFER
0.38		4	AFER
0.64		5	AFER
1.80		6	AFER

Aferir!

Retorne com Cuidado!

14/07/2018

Pág: 002

2.269

0.000



7

AFER





INÍCIO DE PROVA



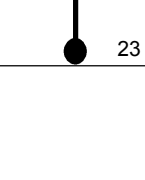

Início da Prova

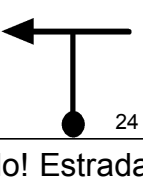

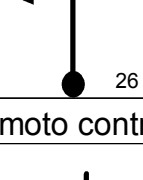
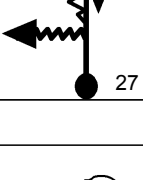
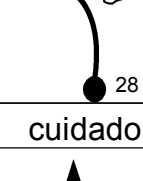
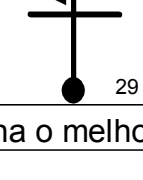
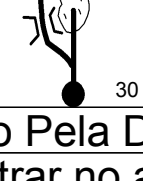
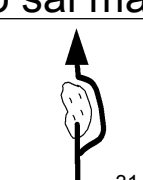
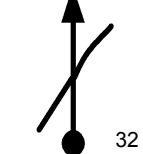

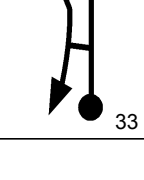
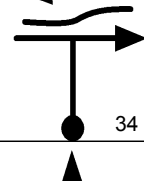
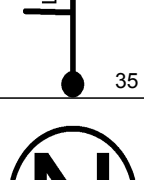
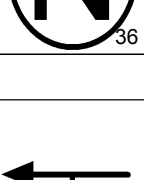
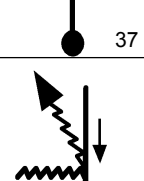
Boa Sorte !

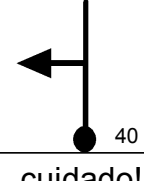
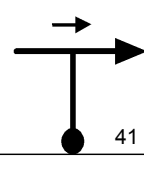
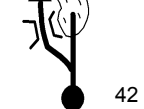



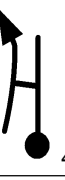
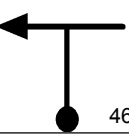
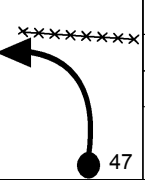
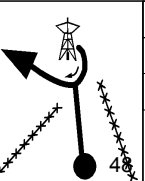
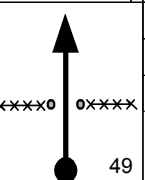
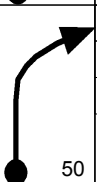

0.00		8	V	25	00.00.00
				25	00.00.00
				25	00.00.00
0.25		9	V	T1	
				25	00.00.36
				25	00.00.36
0.42		10	V	T1	
				25	00.01.00
				25	00.01.00
0.56		11	V	T1	
				25	00.01.21
				25	00.01.21
siga bamp					
0.61		12	V	T2	
				36	00.01.28
				33	00.01.28
Bamp!					
0.65		13	V	T2	
				36	00.01.32
				33	00.01.32
ATENÇÃO!!					
0.77		14	V	T2	
				36	00.01.44
				33	00.01.45
				30	00.01.47

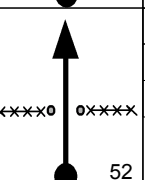

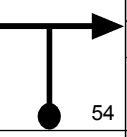

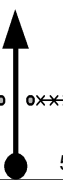
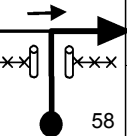

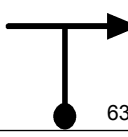

14/07/2018		Pág: 003	
Bamp!			
1.31		36	00.02.38
		33	00.02.44
		30	00.02.52
		V	T2
Bamp!			
1.50		36	00.02.57
		33	00.03.05
		30	00.03.15
		V	T2
Bamp			
1.54		36	00.03.01
		33	00.03.09
		30	00.03.19
		V	T2
Cuidado Estrada Geral!			
1.63		1'	00.03.10
		1'	00.03.19
		1'	00.03.30
		N	T3
Bamp			
1.63		35	00.04.10
		35	00.04.19
		35	00.04.30
		V	T4
2.01		35	00.04.49
		35	00.04.58
		35	00.05.09
		V	T4
2.29		39	00.05.18
		36	00.05.27
		33	00.05.38
		V	T5
2.51		39	00.05.38
		36	00.05.49
		33	00.06.02
		V	T5
Atenção			
2.64		39	00.05.50
		36	00.06.02
		33	00.06.16
		V	T5

14/07/2018		Pág: 004	
2.75		39	00.06.00
		36	00.06.13
		33	00.06.28
		V	T5
Cuidado! Estrada Geral!!!			
2.96		30s	00.06.20
		30s	00.06.34
		30s	00.06.51
		N	T6
2.96		39	00.06.50
		36	00.07.04
		33	00.07.21
		V	T7
moto contra			
3.07		39	00.07.00
		36	00.07.15
		33	00.07.33
		V	T7
Bamp			
3.17		39	00.07.09
		36	00.07.25
		33	00.07.44
		V	T7
cuidado			
3.33		39	00.07.24
		36	00.07.41
		33	00.08.02
		V	T7
escolha o melhor lugar!			
3.41		27	00.07.31
		24	00.07.49
		21	00.08.10
		V	T8
Atenção Pela Direita!!!! Se entrar no atoleiro não sai mais!!!			
3.46		27	00.07.38
		24	00.07.56
		21	00.08.19
		V	T8
3.48		39	00.07.40
		36	00.07.59
		33	00.08.22
		V	T9

14/07/2018		Pág: 005	
3.65		39	00.07.56
		36	00.08.16
		33	00.08.41
		V	T9
Bamp			
3.86		39	00.08.15
		36	00.08.37
		33	00.09.04
		V	T9
4.04		39	00.08.32
		36	00.08.55
		33	00.09.23
		V	T9
4.26		30s	00.08.52
		30s	00.09.17
		30s	00.09.47
		N	T10
Bamp			
4.26		39	00.09.22
		36	00.09.47
		33	00.10.17
		V	T11
4.37		39	00.09.33
		36	00.09.58
		33	00.10.29
		V	T11
4.59		39	00.09.53
		36	00.10.20
		33	00.10.53
		V	T11
4.71		39	00.10.04
		36	00.10.32
		33	00.11.06
		V	T11
cuidado!			
4.79		39	00.10.11
		36	00.10.40
		33	00.11.15
		V	T11
4.84		27	00.10.16
		24	00.10.45
		21	00.11.21
		V	T12



14/07/2018		Pág: 006	
4.89		27 00.10.23	V T12
		24 00.10.53	
		21 00.11.29	
4.91		39 00.10.25	V T13
		36 00.10.56	
		33 00.11.33	
5.09		39 00.10.42	V T13
		36 00.11.14	
		33 00.11.52	
5.42		39 00.11.12	V T13
		36 00.11.47	
		33 00.12.28	
5.66		39 00.11.35	V T13
		36 00.12.11	
		33 00.12.54	
Bamp!			
5.81		39 00.11.48	V T13
		36 00.12.26	
		33 00.13.11	
6.03		39 00.12.09	V T13
		36 00.12.48	
		33 00.13.35	
6.43		39 00.12.46	V T13
		36 00.13.28	
		33 00.14.18	
6.72		50 00.13.12	V T14
		47 00.13.57	
		44 00.14.50	
6.74		50 00.13.14	V T14
		47 00.13.59	
		44 00.14.52	



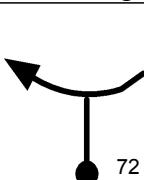
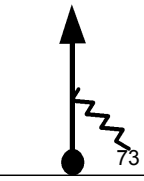
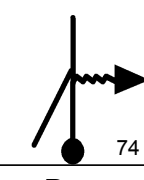
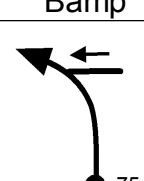
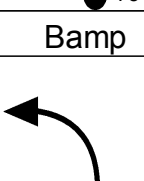
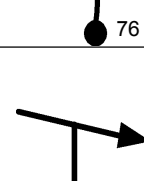
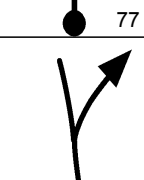
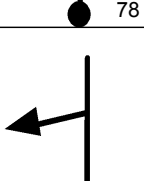
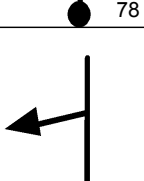
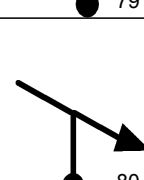
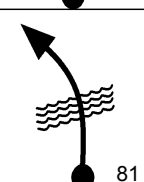

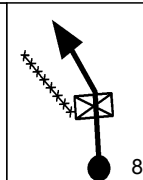
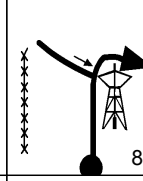
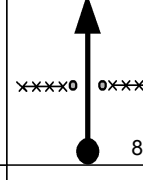
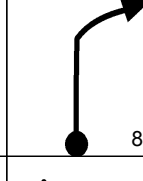
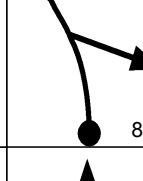
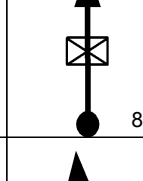
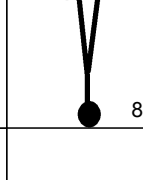
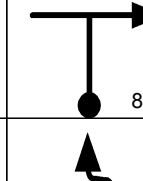
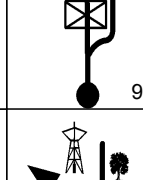
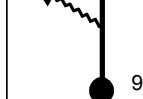

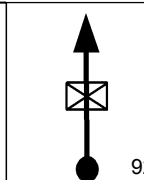

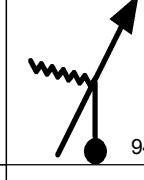
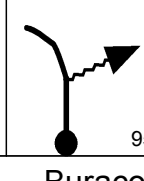
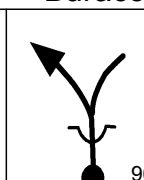
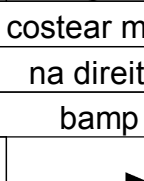
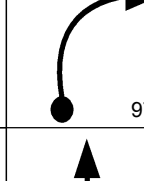
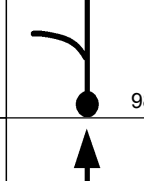
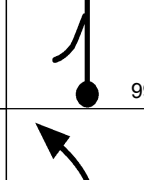
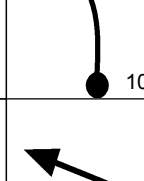
14/07/2018		Pág: 007	
6.78		50 00.13.17	V T14
		47 00.14.02	
		44 00.14.55	
6.84		50 00.13.21	V T14
		47 00.14.06	
		44 00.15.00	
6.93		36 00.13.27	V T15
		33 00.14.13	
		30 00.15.07	
7.00		36 00.13.34	V T15
		33 00.14.21	
		30 00.15.16	
Bamp no eucalipto!			
7.13		36 00.13.47	V T15
		33 00.14.35	
		30 00.15.31	
7.20		39 00.13.54	V T16
		36 00.14.43	
		33 00.15.40	
7.36		39 00.14.09	V T16
		36 00.14.59	
		33 00.15.57	
			
7.64		50 00.14.35	V T17
		47 00.15.27	
		44 00.16.28	
7.66		50 00.14.37	V T17
		47 00.15.28	
		44 00.16.29	



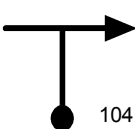



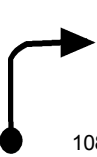
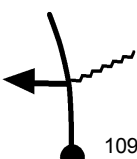

14/07/2018		Pág: 008	
7.71		50 00.14.40	V T17
		47 00.15.32	
		44 00.16.33	
7.76		50 00.14.44	V T17
		47 00.15.36	
		44 00.16.38	
7.86		36 00.14.51	V T18
		33 00.15.43	
		30 00.16.46	
Acelere!			
subida com erosão !!!			
7.93		36 00.14.58	V T18
		33 00.15.51	
		30 00.16.54	
8.38		36 00.15.43	V T18
		33 00.16.40	
		30 00.17.48	
8.43		2' 00.15.48	N T19
		2' 00.16.46	
		30s 00.17.54	
⚠			
8.43		33 00.17.48	V T20
		30 00.18.46	
		27 00.19.24	
8.52		33 00.17.58	V T20
		30 00.18.56	
		27 00.19.36	
8.75		33 00.18.23	V T20
		30 00.19.24	
		27 00.20.07	
Acelere!!			
8.87		33 00.18.36	V T20
		30 00.19.38	
		27 00.20.23	



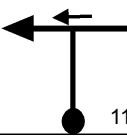



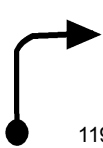

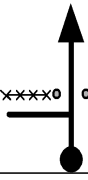

14/07/2018		Pág: 009	
☠☠☠ Cuidado de grauu!!!			
9.11		35	00.19.02
		35	00.20.07
		35	00.20.55
		V	T21
9.28		35	00.19.20
		35	00.20.25
		35	00.21.12
		V	T21
9.31		39	00.19.23
		36	00.20.28
		33	00.21.15
		V	T22
Bamp			
9.55		39	00.19.45
		36	00.20.52
		33	00.21.42
		V	T22
Bamp			
9.61		39	00.19.50
		36	00.20.58
		33	00.21.48
		V	T22
9.71		39	00.20.00
		36	00.21.08
		33	00.21.59
		V	T22
9.99		36	00.20.25
		33	00.21.36
		30	00.22.30
		V	T23
10.06		36	00.20.32
		33	00.21.43
		30	00.22.38
		V	T24
0.00		36	00.20.32
		33	00.21.43
		30	00.22.38
		V	T24
0.04		36	00.20.36
		33	00.21.48
		30	00.22.43
		V	T24
0.31		36	00.21.03
		33	00.22.17
		30	00.23.15
		V	T24



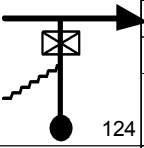

14/07/2018		Pág: 010	
Costear Mato!			
0.39		36	00.21.11
		33	00.22.26
		30	00.23.25
		V	T24
0.61		39	00.21.33
		36	00.22.50
		33	00.23.51
		V	T25
0.83		39	00.21.54
		36	00.23.12
		33	00.24.15
		V	T25
1.23		39	00.22.31
		36	00.23.52
		33	00.24.59
		V	T25
1.51		50	00.22.56
		47	00.24.20
		44	00.25.29
		V	T26
1.53		50	00.22.58
		47	00.24.21
		44	00.25.31
		V	T26
1.57		50	00.23.01
		47	00.24.24
		44	00.25.34
		V	T26
1.63		50	00.23.05
		47	00.24.29
		44	00.25.39
		V	T26
1.73		36	00.23.12
		33	00.24.37
		30	00.25.47
		V	T27
1.79		36	00.23.18
		33	00.24.43
		30	00.25.54
		V	T27

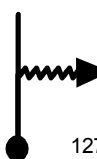
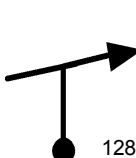



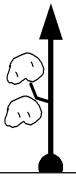

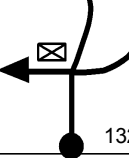
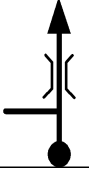
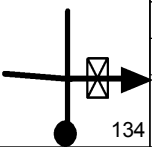
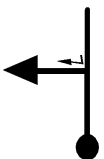

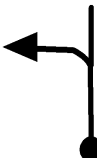
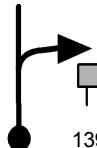
14/07/2018		Pág: 011	
2.25		36	00.24.04
		33	00.25.33
		30	00.26.50
		V	T27
2.30		2'	00.24.09
		1'	00.25.39
		1'	00.26.56
		N	T28
2.30		36	00.26.09
		33	00.26.39
		30	00.27.56
		V	T29
2.56		36	00.26.35
		33	00.27.07
		30	00.28.27
		V	T29
Buraco			
2.73		36	00.26.52
		33	00.27.26
		30	00.28.47
		V	T29
costear mato			
na direita			
bamp			
2.76		36	00.26.55
		33	00.27.29
		30	00.28.51
		V	T29
2.80		36	00.26.59
		33	00.27.33
		30	00.28.56
		V	T29
2.93		36	00.27.12
		33	00.27.48
		30	00.29.11
		V	T29
2.99		36	00.27.18
		33	00.27.54
		30	00.29.18
		V	T29
3.09		45	00.27.28
		42	00.28.05
		39	00.29.30
		V	T30

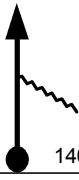

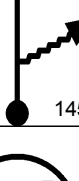

14/07/2018		Pág: 012	
3.51		45	00.28.02
		42	00.28.41
		39	00.30.09
	102	V	T30
3.52		1'	00.28.03
		1'	00.28.42
		30s	00.30.10
	103	N	T31
			
3.52		35	00.29.03
		35	00.29.42
		35	00.30.40
	104	V	T32
3.57		35	00.29.08
		35	00.29.47
		35	00.30.45
	105	V	T32
3.81		39	00.29.33
		36	00.30.12
		33	00.31.10
	106	V	T33
4.01		39	00.29.51
		36	00.30.32
		33	00.31.32
	107	V	T33
4.59		39	00.30.45
		36	00.31.30
		33	00.32.35
	108	V	T33
4.67		33	00.30.52
		30	00.31.38
		27	00.32.44
	109	V	T34
5.03		33	00.31.31
		30	00.32.21
		27	00.33.32
	110	V	T34
Escolha			
5.12		33	00.31.41
		30	00.32.32
		27	00.33.44
	111	V	T34

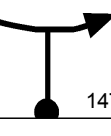
14/07/2018		Pág: 013	
entrada escondida !!			
5.13		30	00.31.42
		27	00.32.33
		24	00.33.45
	112	V	T35
5.69		30	00.32.49
		27	00.33.48
		24	00.35.09
	113	V	T35
5.85		1'30s	00.33.09
		1'30s	00.34.09
		1'	00.35.33
	114	N	T36
5.85		39	00.34.39
		36	00.35.39
		33	00.36.33
	115	V	T37
6.09		39	00.35.01
		36	00.36.03
		33	00.36.59
	116	V	T37
6.30		39	00.35.20
		36	00.36.24
		33	00.37.22
	117	V	T37
6.97		39	00.36.22
		36	00.37.31
		33	00.38.35
	118	V	T37
7.11		39	00.36.35
		36	00.37.45
		33	00.38.51
	119	V	T37
			
7.17		39	00.36.40
		36	00.37.51
		33	00.38.57
	120	V	T37

14/07/2018		Pág: 014	
Entre no Mato!!!			
7.20		39	00.36.43
		36	00.37.54
		33	00.39.00
	121	V	T37
7.46		39	00.37.07
		36	00.38.20
		33	00.39.29
	122	V	T37
7.69		1'30s	00.37.28
		1'30s	00.38.43
		30s	00.39.54
	123	N	T38
			
7.69		35	00.38.58
		35	00.40.13
		35	00.40.24
	124	V	T39
8.89		35	00.41.02
		35	00.42.16
		35	00.42.27
	125	V	T39
10.17		36	00.43.13
		33	00.44.28
		30	00.44.39
	126	V	T40
Descida com Erosões!!!!			
			
0.32		33	00.43.45
		30	00.45.03
		27	00.45.17
	127	V	T41
0.98		36	00.44.57
		33	00.46.22
		30	00.46.45
	128	V	T42
Não erre!!			
Se entrar no atoleiro nao sai mais!			
1.26		27	00.45.25
		24	00.46.53
		21	00.47.19
	129	V	T43

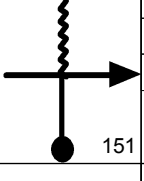
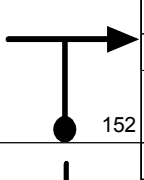
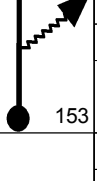
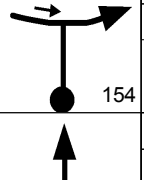
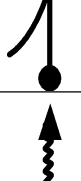
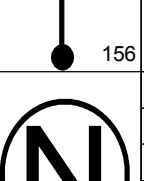
14/07/2018		Pág: 015	
1.28		27	00.45.28
		24	00.46.56
		21	00.47.22
	130	V	T43
1.38		2'	00.45.41
		2'	00.47.11
		2'	00.47.40
		N	T44
1.38		35	00.47.41
		35	00.49.11
		35	00.49.40
	132	V	T45
☠☠erigo ponte estreita !!!!!			
2.65		35	00.49.52
		35	00.51.21
		35	00.51.50
		V	T45
	133		
4.29		35	00.52.41
		35	00.54.10
		35	00.54.39
		V	T45
	134		
Bamp			
4.70		36	00.53.23
		33	00.54.52
		30	00.55.21
		V	T46
	135		
4.88		36	00.53.41
		33	00.55.12
		30	00.55.43
		V	T46
	136		
4.93		36	00.53.46
		33	00.55.17
		30	00.55.49
		V	T46
	137		
4.99		36	00.53.52
		33	00.55.24
		30	00.55.56
		V	T46
	138		
5.09		36	00.54.02
		33	00.55.35
		30	00.56.08
		V	T46
	139		

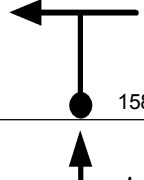
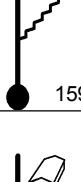
14/07/2018		Pág: 016	
☠☠trafego de caminhoes			
5.15		33	00.54.08
		30	00.55.41
		27	00.56.15
		V	T47
	140		
5.55		33	00.54.52
		30	00.56.29
		27	00.57.08
		V	T47
	141		
5.60		33	00.54.57
		30	00.56.35
		27	00.57.15
		V	T47
	142		
5.65		33	00.55.02
		30	00.56.41
		27	00.57.22
		V	T47
	143		
5.71		33	00.55.09
		30	00.56.48
		27	00.57.30
		V	T47
	144		
6.13		33	00.55.55
		30	00.57.39
		27	00.58.26
		V	T47
	145		
6.15		1'	00.55.57
		1'	00.57.41
		1'	00.58.28
		N	T48
	146		
6.15		36	00.56.57
		33	00.58.41
		30	00.59.28
		V	T49
	147		
6.41		36	00.57.23
		33	00.59.10
		30	01.00.00
		V	T49
	148		
6.62		36	00.57.44
		33	00.59.33
		30	01.00.25
		V	T49
	149		

14/07/2018		Pág: 017	
6.88		36	00.58.10
		33	01.00.01
		30	01.00.56
		V	T49
	150		
6.97		36	00.58.19
		33	01.00.11
		30	01.01.07
		V	T49
	151		
7.03		20	00.58.25
		20	01.00.17
		20	01.01.14
		V	T50
	152		
7.36		36	00.59.24
		33	01.01.17
		30	01.02.13
		V	T51
	153		
7.40		36	00.59.28
		33	01.01.21
		30	01.02.18
		V	T51
	154		
7.66		36	00.59.54
		33	01.01.49
		30	01.02.49
		V	T51
	155		
7.75		36	01.00.03
		33	01.01.59
		30	01.03.00
		V	T51
	156		
8.08		2'	01.00.36
		2'	01.02.35
		2'	01.03.40
		N	T52
	157		
8.08		35	01.02.36
		35	01.04.35
		35	01.05.40
		V	T53
	158		
8.08		35	01.02.44
		35	01.04.42
		35	01.05.47
		V	T53
	159		
8.96		35	01.04.07
		35	01.06.06
		35	01.07.10
		V	T53
	160		

14/07/2018		Pág: 018	
9.39		35 01.04.51	
		35 01.06.50	
		35 01.07.54	
	V	T53	
9.67		35 01.05.20	
		35 01.07.19	
		35 01.08.23	
	V	T53	
10.02		39 01.05.56	
		36 01.07.55	
		33 01.08.59	
0.00	V	T54	
0.32		39 01.06.25	
		36 01.08.27	
		33 01.09.34	
	V	T54	
0.41		39 01.06.34	
		36 01.08.36	
		33 01.09.44	
	V	T54	
0.52		39 01.06.44	
		36 01.08.47	
		33 01.09.56	
	V	T54	
0.56		39 01.06.48	
		36 01.08.51	
		33 01.10.00	
	V	T54	
Erosões!!!!!!!			
0.68		36 01.06.59	
		33 01.09.03	
		30 01.10.13	
	V	T55	
1.33		25 01.08.04	
		22 01.10.14	
		19 01.11.31	
	V	T56	
Escolha o melhor lugar!!!			
Perigo!!			
1.36		25 01.08.08	
		22 01.10.19	
		19 01.11.37	
	V	T56	





14/07/2018		Pág: 019	
1.51		36 01.08.30	
		33 01.10.43	
		30 01.12.06	
	V	T57	
1.90		36 01.09.09	
		33 01.11.26	
		30 01.12.52	
	V	T57	
Bamp!			
2.29		36 01.09.48	
		33 01.12.08	
		30 01.13.39	
	V	T57	
2.47		36 01.10.06	
		33 01.12.28	
		30 01.14.01	
	V	T57	
2.52		36 01.10.11	
		33 01.12.33	
		30 01.14.07	
	V	T57	
2.58		36 01.10.17	
		33 01.12.40	
		30 01.14.14	
	V	T57	
2.68		36 01.10.27	
		33 01.12.51	
		30 01.14.26	
	V	T57	
☠☠trafego de caminhoes			
2.74		27 01.10.33	
		27 01.12.57	
		27 01.14.33	
	V	T58	
3.06		27 01.11.15	
		27 01.13.40	
		27 01.15.16	
	V	T58	

14/07/2018		Pág: 020	
liso!			
Acelere			
3.14		33 01.11.26	
		30 01.13.51	
		27 01.15.26	
	V	T59	
☠☠ liso			
3.25		33 01.11.38	
		30 01.14.04	
		27 01.15.41	
	V	T59	
3.39		36 01.11.53	
		33 01.14.21	
		30 01.16.00	
	V	T60	
3.46		36 01.12.00	
		33 01.14.28	
		30 01.16.08	
	V	T60	
3.53		36 01.12.07	
		33 01.14.36	
		30 01.16.17	
	V	T60	
3.58		36 01.12.12	
		33 01.14.41	
		30 01.16.23	
	V	T60	
3.65		36 01.12.19	
		33 01.14.49	
		30 01.16.31	
	V	T60	
3.71		36 01.12.25	
		33 01.14.56	
		30 01.16.38	
	V	T60	
3.78		36 01.12.32	
		33 01.15.03	
		30 01.16.47	
	V	T60	
3.81		36 01.12.35	
		33 01.15.06	
		30 01.16.50	
	V	T60	

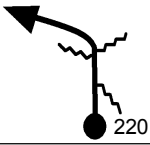
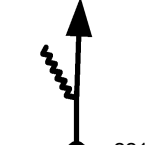
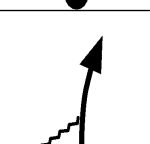

14/07/2018		Pág: 021	
3.88		36 01.12.42	
		33 01.15.14	
		30 01.16.59	
		V	T60
3.94		36 01.12.48	
		33 01.15.21	
		30 01.17.06	
		V	T60
3.98		36 01.12.52	
		33 01.15.25	
		30 01.17.11	
		V	T60
4.05		36 01.12.59	
		33 01.15.33	
		30 01.17.19	
		V	T60
4.15		36 01.13.09	
		33 01.15.44	
		30 01.17.31	
		V	T60
4.46		36 01.13.40	
		33 01.16.17	
		30 01.18.08	
		V	T60
☠			
4.53		2' 01.13.47	
		1' 01.16.25	
		1' 01.18.17	
		N	T61
4.53		35 01.15.47	
		35 01.17.25	
		35 01.19.17	
		V	T62
4.58		35 01.15.52	
		35 01.17.30	
		35 01.19.22	
		V	T62
4.85		36 01.16.20	
		33 01.17.58	
		30 01.19.50	
		V	T63

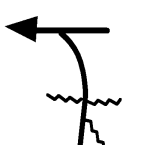
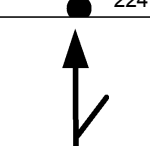
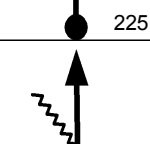
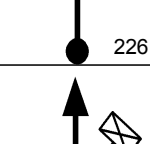
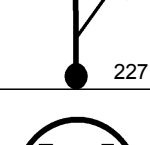
14/07/2018		Pág: 022	
5.05		36 01.16.40	
		33 01.18.20	
		30 01.20.14	
		V	T63
5.32		36 01.17.07	
		33 01.18.49	
		30 01.20.46	
		V	T63
5.42		36 01.17.17	
		33 01.19.00	
		30 01.20.58	
		V	T63
5.73		1' 01.17.48	
		30s 01.19.34	
		30s 01.21.35	
		N	T64
☠			
5.73		35 01.18.48	
		35 01.20.04	
		35 01.22.05	
		V	T65
5.80		35 01.18.55	
		35 01.20.11	
		35 01.22.12	
		V	T65
6.36		35 01.19.53	
		35 01.21.09	
		35 01.23.10	
		V	T65
6.61		35 01.20.19	
		35 01.21.34	
		35 01.23.36	
		V	T65
7.05		35 01.21.04	
		35 01.22.20	
		35 01.24.21	
		V	T65
7.32		35 01.21.32	
		35 01.22.47	
		35 01.24.49	
		V	T65

14/07/2018		Pág: 023	
7.68		35 01.22.09	
		35 01.23.24	
		35 01.25.26	
		V	T65
8.18		36 01.23.00	
		33 01.24.16	
		30 01.26.17	
		V	T66
Acelere!			
8.22		36 01.23.04	
		33 01.24.20	
		30 01.26.22	
		V	T66
Atoleiro!!!!!!!			
8.82		36 01.24.04	
		33 01.25.26	
		30 01.27.34	
		V	T66
8.98		36 01.24.20	
		33 01.25.43	
		30 01.27.53	
		V	T66
9.06		39 01.24.28	
		36 01.25.52	
		33 01.28.03	
		V	T67
9.39		39 01.24.59	
		36 01.26.25	
		33 01.28.39	
		V	T67
9.52		39 01.25.11	
		36 01.26.38	
		33 01.28.53	
		V	T67
9.63		39 01.25.21	
		36 01.26.49	
		33 01.29.05	
		V	T67
9.88		39 01.25.44	
		36 01.27.14	
		33 01.29.32	
		V	T67

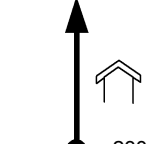
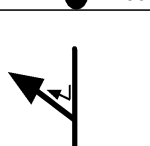
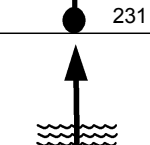
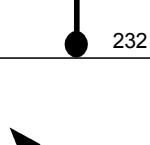
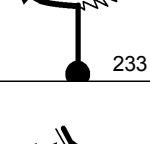
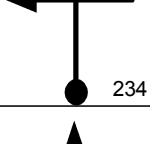
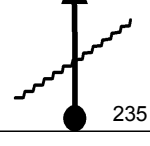
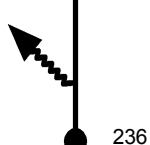
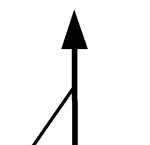
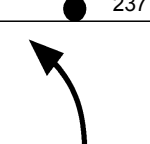
14/07/2018		Pág: 024	
10.04		39	01.25.59
		36	01.27.30
		33	01.29.50
	V	T67	
10.10		39	01.26.04
		36	01.27.36
		33	01.29.56
	V	T67	
10.26		39	01.26.19
		36	01.27.52
		33	01.30.14
	V	T67	
10.39		2'	01.26.31
		1'	01.28.05
		1'	01.30.28
	N	T68	
			
10.39		35	01.28.31
		35	01.29.05
		35	01.31.28
	V	T69	
10.54		35	01.28.46
		35	01.29.20
		35	01.31.43
	V	T69	
10.57		35	01.28.49
		35	01.29.23
		35	01.31.46
	V	T69	
10.70		35	01.29.03
		35	01.29.37
		35	01.32.00
	V	T69	
10.74		20'	01.29.07
		20'	01.29.41
		18'	01.32.04
	N	T70	
Início 2ª Etapa			
0.00		20	01.49.07
		20	01.49.41
		20	01.50.04
	V	T71	

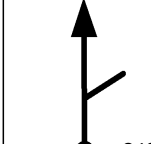
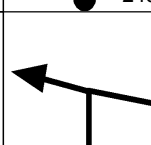
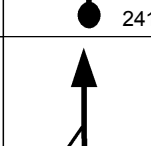
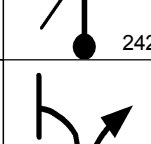
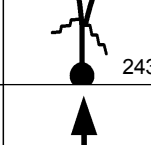
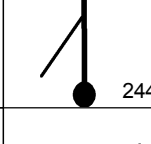
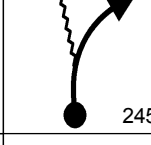
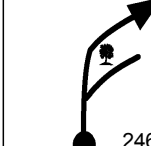
14/07/2018		Pág: 025	
Cavalo velho!!			
0.03		20	01.49.12
		20	01.49.46
		20	01.50.09
	V	T71	
0.10		39	01.49.25
		36	01.49.59
		33	01.50.22
	V	T72	
0.44		39	01.49.56
		36	01.50.33
		33	01.50.59
	V	T72	
0.57		39	01.50.08
		36	01.50.46
		33	01.51.13
	V	T72	
0.68		39	01.50.18
		36	01.50.57
		33	01.51.25
	V	T72	
0.90		39	01.50.39
		36	01.51.19
		33	01.51.49
	V	T72	
0.92		39	01.50.41
		36	01.51.21
		33	01.51.51
	V	T72	
0.98		39	01.50.46
		36	01.51.27
		33	01.51.58
	V	T72	
1.07		39	01.50.54
		36	01.51.36
		33	01.52.08
	V	T72	
1.10		39	01.50.57
		36	01.51.39
		33	01.52.11
	V	T72	

14/07/2018		Pág: 026	
			
1.14		39	01.51.01
		36	01.51.43
		33	01.52.15
	V	T72	
1.21		39	01.51.07
		36	01.51.50
		33	01.52.23
	V	T72	
1.27		39	01.51.13
		36	01.51.56
		33	01.52.29
	V	T72	
1.36		39	01.51.21
		36	01.52.05
		33	01.52.39
	V	T72	
1.51		39	01.51.35
		36	01.52.20
		33	01.52.56
	V	T72	
1.70		39	01.51.53
		36	01.52.39
		33	01.53.16
	V	T72	
1.94		39	01.52.15
		36	01.53.03
		33	01.53.43
	V	T72	
2.07		39	01.52.27
		36	01.53.16
		33	01.53.57
	V	T72	
2.30		39	01.52.48
		36	01.53.39
		33	01.54.22
	V	T72	

14/07/2018		Pág: 027	
2.32		39	01.52.50
		36	01.53.41
		33	01.54.24
		V	T72
2.49		39	01.53.06
		36	01.53.58
		33	01.54.43
		V	T72
2.66		39	01.53.21
		36	01.54.15
		33	01.55.01
		V	T72
2.71		39	01.53.26
		36	01.54.20
		33	01.55.07
		V	T72
2.82		39	01.53.36
		36	01.54.31
		33	01.55.19
		V	T72
2.96		36	01.53.49
		33	01.54.45
		30	01.55.34
		V	T73
3.10		36	01.54.03
		33	01.55.00
		30	01.55.51
		V	T73
3.45		36	01.54.38
		33	01.55.38
		30	01.56.33
		V	T73
3.65		36	01.54.58
		33	01.56.00
		30	01.56.57
		V	T73
3.67		36	01.55.00
		33	01.56.02
		30	01.56.59
		V	T73
3.81		36	01.55.14
		33	01.56.18
		30	01.57.16
		V	T73

14/07/2018		Pág: 028	
3.83		36	01.55.16
		33	01.56.20
		30	01.57.18
		V	T73
3.87		36	01.55.20
		33	01.56.24
		30	01.57.23
		V	T73
3.95		36	01.55.28
		33	01.56.33
		30	01.57.33
		V	T73
3.97		36	01.55.30
		33	01.56.35
		30	01.57.35
		V	T73
4.10		36	01.55.43
		33	01.56.49
		30	01.57.51
		V	T73
4.12		36	01.55.45
		33	01.56.51
		30	01.57.53
		V	T73
4.22		36	01.55.55
		33	01.57.02
		30	01.58.05
		V	T73
4.31		36	01.56.04
		33	01.57.12
		30	01.58.16
		V	T73
4.33		36	01.56.06
		33	01.57.14
		30	01.58.18
		V	T73
4.38		36	01.56.11
		33	01.57.20
		30	01.58.24
		V	T73
4.44		36	01.56.17
		33	01.57.26
		30	01.58.31
		V	T73

14/07/2018		Pág: 029	
4.74		4'	01.56.47
		4'	01.57.59
		4'	01.59.07
		N	T74
Por Favor Respeite a Propriedade!!!			
4.74		12	02.00.47
		12	02.01.59
		12	02.03.07
		V	T75
4.83		12	02.01.14
		12	02.02.26
		12	02.03.34
		V	T75
4.92		12	02.01.41
		12	02.02.53
		12	02.04.01
		V	T75
4.94		36	02.01.47
		33	02.02.59
		30	02.04.07
		V	T76
5.02		36	02.01.55
		33	02.03.08
		30	02.04.17
		V	T76
5.36		36	02.02.29
		33	02.03.45
		30	02.04.58
		V	T76
5.59		36	02.02.52
		33	02.04.10
		30	02.05.25
		V	T76
5.72		36	02.03.05
		33	02.04.24
		30	02.05.41
		V	T76
5.79		36	02.03.12
		33	02.04.32
		30	02.05.49
		V	T76

14/07/2018		Pág: 030	
5.86		36	02.03.19
		33	02.04.39
		30	02.05.58
		V	T76
6.04		36	02.03.37
		33	02.04.59
		30	02.06.19
		V	T76
6.08		36	02.03.41
		33	02.05.03
		30	02.06.24
		V	T76
6.52		36	02.04.25
		33	02.05.51
		30	02.07.17
		V	T76
6.57		36	02.04.30
		33	02.05.57
		30	02.07.23
		V	T76
6.62		36	02.04.35
		33	02.06.02
		30	02.07.29
		V	T76
Cuidado Trilha com pedras e degraus!!			
☠☠☠isco de morte!!			
6.76		21	02.04.49
		18	02.06.18
		15	02.07.46
		V	T77
7.13		33	02.05.52
		30	02.07.32
		27	02.09.15
		V	T78
7.33		33	02.06.14
		30	02.07.56
		27	02.09.41
		V	T78
7.47		33	02.06.29
		30	02.08.12
		27	02.10.00
		V	T78

14/07/2018		Pág: 031	
7.68		33	02.06.52
		30	02.08.38
		27	02.10.28
		V	T78
7.74		2'	02.06.59
		2'	02.08.45
		2'	02.10.36
		N	T79
Bamp!!			
Respeite o Gado !!			
Gado arisco!!!!			
7.74		15	02.08.59
		15	02.10.45
		15	02.12.36
		V	T80
Costear o Gravata			
7.94		15	02.09.47
		15	02.11.33
		15	02.13.24
		V	T80
8.05		15	02.10.13
		15	02.11.59
		15	02.13.50
		V	T80
Respeite os moradores!!			
8.10		15	02.10.25
		15	02.12.11
		15	02.14.02
		V	T80
8.16		15	02.10.40
		15	02.12.26
		15	02.14.17
		V	T80
8.31		35	02.11.16
		35	02.13.02
		35	02.14.53
		V	T81
9.23		35	02.12.50
		35	02.14.36
		35	02.16.27
		V	T82
0.00			







14/07/2018		Pág: 032	
2.32		35	02.16.49
		35	02.18.35
		35	02.20.26
		V	T82
3.04		35	02.18.03
		35	02.19.49
		35	02.21.40
		V	T82
3.35		35	02.18.35
		35	02.20.21
		35	02.22.12
		V	T82
5.02		35	02.21.27
		35	02.23.13
		35	02.25.04
		V	T82
5.57		35	02.22.23
		35	02.24.09
		35	02.26.00
		V	T82
Costear muro!!			
6.53		15	02.24.02
		15	02.25.48
		15	02.27.39
		V	T83
6.62		15	02.24.24
		15	02.26.09
		15	02.28.01
		V	T83
em direção ao mato			
6.67		30	02.24.36
		30	02.26.21
		30	02.28.13
		V	T84
6.80		36	02.24.51
		33	02.26.37
		30	02.28.28
		V	T85

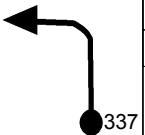
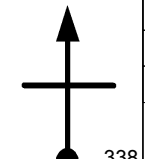
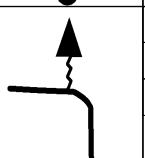
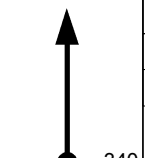
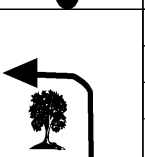
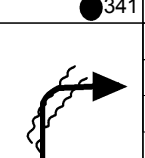
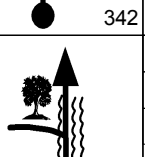
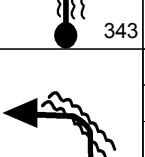
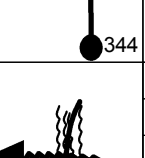
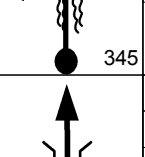

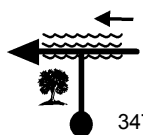
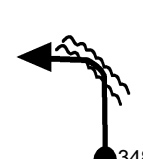
14/07/2018		Pág: 033	
7.02		36	02.25.13
		33	02.27.01
		30	02.28.55
		V	T85
costear mato!!			
7.40		36	02.25.51
		33	02.27.43
		30	02.29.40
		V	T85
7.45		36	02.25.56
		33	02.27.48
		30	02.29.46
		V	T85
7.54		36	02.26.05
		33	02.27.58
		30	02.29.57
		V	T85
7.64		36	02.26.15
		33	02.28.09
		30	02.30.09
		V	T85
7.82		1'	02.26.33
		30s	02.28.28
		30s	02.30.31
		N	T86
7.82		36	02.27.33
		33	02.28.58
		30	02.31.01
		V	T87
7.88		36	02.27.39
		33	02.29.05
		30	02.31.08
		V	T87
8.14		36	02.28.05
		33	02.29.33
		30	02.31.39
		V	T87
8.29		36	02.28.20
		33	02.29.50
		30	02.31.57
		V	T87

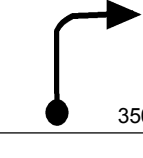

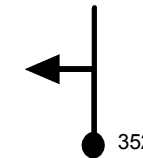

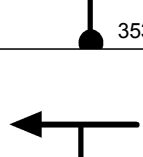
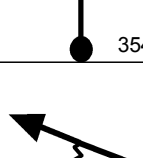
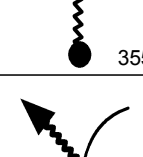

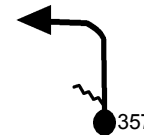
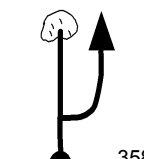
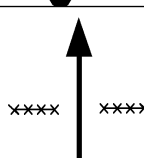

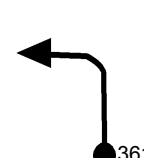
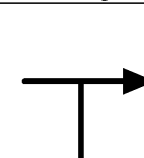
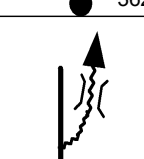
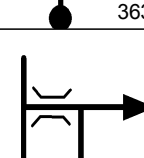
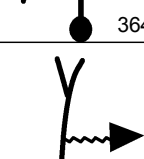
14/07/2018		Pág: 034	
8.47		1'	02.28.38
		30s	02.30.09
		30s	02.32.19
		N	T88
0.00		35	02.29.38
		35	02.30.39
		35	02.32.49
		V	T89
0.23		35	02.30.02
		35	02.31.03
		35	02.33.12
		V	T89
0.74		25	02.30.54
		25	02.31.55
		25	02.34.05
		V	T90
0.87		25	02.31.13
		25	02.32.14
		25	02.34.23
		V	T90
Bamp			
1.13		36	02.31.50
		33	02.32.52
		30	02.35.01
		V	T91
Costear mato!!			
1.30		36	02.32.07
		33	02.33.10
		30	02.35.21
		V	T91
Costear Mato!!			
1.35		36	02.32.12
		33	02.33.16
		30	02.35.27
		V	T91
costear mato..			
1.44		36	02.32.21
		33	02.33.25
		30	02.35.38
		V	T91



14/07/2018		Pág: 035	
1.60		36	02.32.37
		33	02.33.43
		30	02.35.57
		V	T91
1.83		33	02.33.00
		30	02.34.08
		27	02.36.25
		V	T92
2.19		33	02.33.40
		30	02.34.51
		27	02.37.13
		V	T92
Costear mato!!			
2.29		39	02.33.51
		36	02.35.03
		33	02.37.26
		V	T93
costear bananeira!!!			
2.49		39	02.34.09
		36	02.35.23
		33	02.37.48
		V	T93
costear mato			
2.87		39	02.34.44
		36	02.36.01
		33	02.38.29
		V	T93
2.94		33	02.34.51
		30	02.36.08
		27	02.38.37
		V	T94
3.28		36	02.35.28
		33	02.36.49
		30	02.39.22
		V	T95
costear mato!!			
3.52		36	02.35.52
		33	02.37.15
		30	02.39.51
		V	T95
costear bananeira !!!			

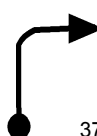

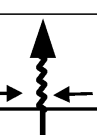

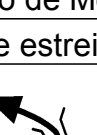
14/07/2018		Pág: 036	
3.63		36	02.36.03
		33	02.37.27
		30	02.40.04
		V	T95
3.72		36	02.36.12
		33	02.37.37
		30	02.40.15
		V	T95
3.76		36	02.36.16
		33	02.37.41
		30	02.40.20
		V	T95
☠☠☠ Cuidado descida !!			
3.96		27	02.36.36
		24	02.38.03
		21	02.40.44
		V	T96
4.05		27	02.36.48
		24	02.38.17
		21	02.40.59
		V	T96
4.22		18	02.37.10
		15	02.38.42
		12	02.41.29
		V	T97
4.24		18	02.37.14
		15	02.38.47
		12	02.41.35
		V	T97
4.26		18	02.37.18
		15	02.38.52
		12	02.41.41
		V	T97
4.34		18	02.37.34
		15	02.39.11
		12	02.42.05
		V	T97
4.38		18	02.37.42
		15	02.39.20
		12	02.42.17
		V	T97

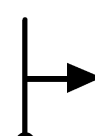
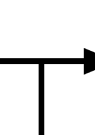
14/07/2018		Pág: 037	
4.41		18	02.37.48
		15	02.39.28
		12	02.42.26
		V	T97
4.43		18	02.37.52
		15	02.39.32
		12	02.42.32
		V	T97
4.52		18	02.38.10
		15	02.39.54
		12	02.42.59
		V	T97
4.63		36	02.38.32
		33	02.40.20
		30	02.43.32
		V	T98
4.94		4'	02.39.03
		3'	02.40.54
		3'	02.44.09
		N	T99
4.94		33	02.43.03
		30	02.43.54
		27	02.47.09
		V	T100
no mato!!			
5.00		33	02.43.10
		30	02.44.01
		27	02.47.17
		V	T100
5.33		33	02.43.46
		30	02.44.41
		27	02.48.01
		V	T100
5.72		33	02.44.28
		30	02.45.28
		27	02.48.53
		V	T100
5.75		33	02.44.32
		30	02.45.31
		27	02.48.57
		V	T100

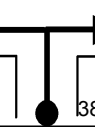
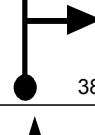
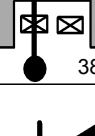
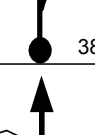
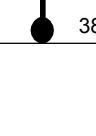
14/07/2018		Pág: 038	
6.30		33	02.45.32
		30	02.46.37
		27	02.50.10
		V	T100
6.52		33	02.45.56
		30	02.47.04
		27	02.50.39
		V	T100
6.59		33	02.46.03
		30	02.47.12
		27	02.50.49
		V	T100
			
☠☠			
6.72		39	02.46.18
		36	02.47.28
		33	02.51.06
		V	T101
6.85		39	02.46.30
		36	02.47.41
		33	02.51.20
		V	T101
7.02		30	02.46.45
		27	02.47.58
		24	02.51.39
		V	T102
7.03		30	02.46.46
		27	02.47.59
		24	02.51.40
		V	T102
7.40		30	02.47.31
		27	02.48.49
		24	02.52.36
		V	T102
7.56		30	02.47.50
		27	02.49.10
		24	02.53.00
		V	T102

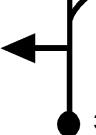
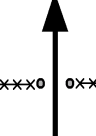
14/07/2018		Pág: 039	
7.83		30	02.48.22
		27	02.49.46
		24	02.53.40
	366	V	T102
7.91		36	02.48.32
		33	02.49.57
		30	02.53.52
	367	V	T103
7.94		36	02.48.35
		33	02.50.00
		30	02.53.56
	368	V	T103
☠☠			
8.17		36	02.48.58
		33	02.50.25
		30	02.54.24
	369	V	T103
8.40		36	02.49.21
		33	02.50.50
		30	02.54.51
	370	V	T103
Cuidado estrada geral!!			
8.72		1'	02.49.53
		1'	02.51.25
		30s	02.55.30
	371	N	T104
☠☠			
8.72		36	02.50.53
		33	02.52.25
		30	02.56.00
	372	V	T105
8.85		36	02.51.06
		33	02.52.39
		30	02.56.15
	373	V	T105
Perigo de Morte!!			
☠☠☠ ponte estreita !!!			
8.94		36	02.51.15
		33	02.52.49
		30	02.56.26
	374	V	T105

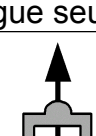
14/07/2018		Pág: 040	
9.19		36	02.51.40
		33	02.53.16
		30	02.56.56
	375	V	T105
9.34		36	02.51.55
		33	02.53.32
		30	02.57.14
	376	V	T105
9.83		30	02.52.44
		30	02.54.26
		30	02.58.13
	377	V	T106
☠☠			
10.32		35	02.53.43
		35	02.55.25
		35	02.59.12
	378	V	T107
10.68		35	02.54.20
		35	02.56.02
		35	02.59.49
	379	V	T107
11.49		35	02.55.43
		35	02.57.25
		35	03.01.12
	380	V	T107
13.13		25	02.58.32
		25	03.00.14
		25	03.04.01
	381	V	T108
13.15		25	02.58.35
		25	03.00.17
		25	03.04.03
	382	V	T108
13.26		25	02.58.51
		25	03.00.32
		25	03.04.19
	383	V	T108
13.43		25	02.59.15
		25	03.00.57
		25	03.04.44
	384	V	T108

14/07/2018		Pág: 041	
13.57		25	02.59.35
		25	03.01.17
		25	03.05.04
	385	V	T108
13.63		25	02.59.44
		25	03.01.26
		25	03.05.13
	386	V	T108
13.65		25	02.59.47
		25	03.01.29
		25	03.05.15
	387	V	T108
Fim! Parabéns !!			
Entregue seu colete!!			
13.67		25	02.59.50
		25	03.01.32
		25	03.05.18
	388	V	T108
FIM DE PROVA !!			
			
www.t15.com.br			
Tempo de Prova			
MÉDIA A 02:59:50			
MÉDIA B 03:01:32			
MÉDIA C 03:05:18			
FIM			