

# INICIO

## OVER 40/JUNIOR

COPA MTC  
25/05/2019



## IMPORTANTE

Média "A" para Graduados

Média "B" para Over 40,  
Júnior

Média "C" para Over 45,  
Duplas, Estreantes e  
Equipes

**CUIDADO AO ATRAVESSAR AS  
ESTRADAS!!!**

**CUIDADO COM AS  
CRIANÇAS!!!**

**CUIDE DA SUA VIDA E DA  
DO SEU COLEGA DE  
ESPORTE!!!!**



**CUIDADO**



**ATENÇÃO**



**MUITA ATENÇÃO**



# Tempo de Prova



OVER 40/JUNIOR 03:01:46







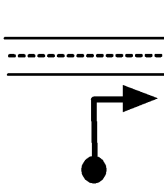
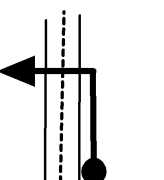

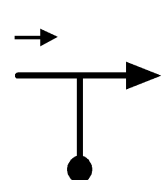
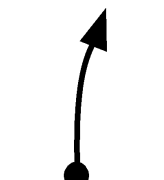
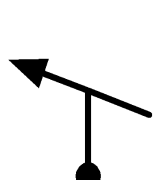
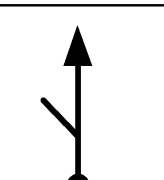
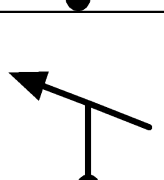
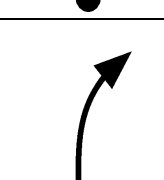
## AFERIÇÃO

	0.00
	1 AFER
	0.71
	2 AFER
	1.17
	3 AFER
	1.60
	4 AFER
	1.67
	5 AFER
	1.75
	6 AFER

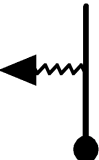
	1.83	
	7	AFER
	2.00	
	0.00	
	8	AFER
		
<b>INICIO DE PROVA</b>		
	0.00	
	V 33	00.00.00
	9	T1
	0.08	
	V 33	00.00.09
	10	T1
	0.62	
	V 33	00.01.08
	11	T1
	0.66	
	V 33	00.01.12
	12	T1

	<b>0.74</b>
D 3'	00.01.21
13	<b>T2</b>
	<b>0.93</b>
V 33	00.04.21
14	<b>T3</b>
	
	<b>0.98</b>
V 42	00.04.26
15	<b>T4</b>
	<b>1.21</b>
V 42	00.04.46
16	<b>T4</b>
	<b>1.23</b>
V 42	00.04.48
17	<b>T4</b>
	<b>1.29</b>
V 42	00.04.53
18	<b>T4</b>
	<b>1.43</b>
V 42	00.05.05
19	<b>T4</b>
	<b>1.49</b>
V 42	00.05.10
20	<b>T4</b>

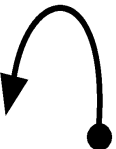
	1.51
	V 27 00.05.12
	21 <b>T5</b>
	1.91
	V 27 00.06.05
	22 <b>T5</b>
	1.99
	V 42 00.06.16
	23 <b>T6</b>
PELA ESQUERDA	
BAMP	
	2.14
	V 42 00.06.28
	24 <b>T6</b>
	2.36
	V 42 00.06.47
	25 <b>T6</b>
	2.43
	V 48 00.06.53
	26 <b>T7</b>
	2.82
	V 48 00.07.23
	27 <b>T7</b>
	2.87
	V 48 00.07.26
	28 <b>T7</b>





	<b>3.25</b>	
	V 48	00.07.55
	29	<b>T7</b>
	<b>3.28</b>	
	V 33	00.07.57
	30	<b>T8</b>
	<b>3.39</b>	
	V 39	00.08.09
	31	<b>T9</b>
<b>CUIDADO</b>		
VALO		
		
	<b>3.47</b>	
	V 39	00.08.16
	32	<b>T9</b>
<b>BAMP</b>		
	<b>3.70</b>	
	V 39	00.08.38
	33	<b>T9</b>
<b>SUBA</b>		
<b>BAMP</b>		
	<b>3.75</b>	
	V 30	00.08.42
	34	<b>T10</b>
	<b>3.80</b>	
	V 30	00.08.48
	35	<b>T10</b>

BAMP

	<b>3.92</b>	
	V 30	00.09.03
	36	<b>T10</b>
	<b>4.03</b>	
	V 30	00.09.16
	37	<b>T10</b>
<del>X</del>		
	<b>4.24</b>	
	V 42	00.09.41
	38	<b>T11</b>
	<b>4.46</b>	
	V 42	00.10.00
	39	<b>T11</b>
	<b>4.50</b>	
	V 42	00.10.03
	40	<b>T11</b>
	<b>4.56</b>	
	V 42	00.10.08
	41	<b>T11</b>
	<b>4.69</b>	
	V 42	00.10.20
	42	<b>T11</b>
	<b>4.74</b>	
	V 42	00.10.24
	43	<b>T11</b>

	4.78
	V 27 00.10.27
	44 <b>T12</b>
	5.26
	V 42 00.11.31
	45 <b>T13</b>
COSTER	
O MATO	
	5.40
	V 42 00.11.43
	46 <b>T13</b>
	5.49
	V 42 00.11.51
	47 <b>T13</b>
	5.54
	V 48 00.11.55
	48 <b>T14</b>
	5.72
	V 48 00.12.09
	49 <b>T14</b>
	6.11
	V 48 00.12.38
	50 <b>T14</b>
	6.16
	V 48 00.12.42
	51 <b>T14</b>

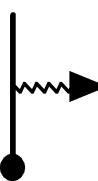
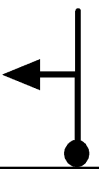

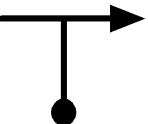
	<b>6.54</b>	
	V 24	00.13.10
	52	<b>T15</b>
COSTEAR O BARRANCO		
	<b>6.59</b>	
	V 24	00.13.18
	53	<b>T15</b>
	<b>6.75</b>	
	V 24	00.13.42
	54	<b>T15</b>
BAMP		
	<b>6.87</b>	
	V 24	00.14.00
	55	<b>T15</b>
	<b>6.91</b>	
	V 24	00.14.06
	56	<b>T15</b>
NO MATO		
	<b>7.06</b>	
	V 24	00.14.28
	57	<b>T15</b>
	<b>7.25</b>	
	N 1'	00.14.57
	58	<b>T16</b>
	<b>7.25</b>	
	V 48	00.15.57
	59	<b>T17</b>



	7.50
	V 48   00.16.16
	60   <b>T17</b>
	7.55
	V 48   00.16.19
	61   <b>T17</b>
	7.77
	V 24   00.16.36
	62   <b>T18</b>
VALO	
	7.96
	V 24   00.17.04
	63   <b>T18</b>
SUBA	
	7.99
	V 24   00.17.09
	64   <b>T18</b>
	8.00
	V 24   00.17.10
	65   <b>T18</b>
CUIDADO	
AÇUDE	
	8.15
	V 24   00.17.33
	66   <b>T18</b>

	8.22	
	V 24	00.17.43
	67	<b>T18</b>



	8.29	
	V 45	00.17.54
	68	<b>T19</b>



	8.57	
	V 45	00.18.16
	69	<b>T19</b>

LAGO

	8.93	
	V 54	00.18.45
	70	<b>T20</b>



	9.32	
	V 54	00.19.11
	71	<b>T20</b>

	9.72	
	V 54	00.19.38
	72	<b>T20</b>

	9.80	
	V 33	00.19.43
	73	<b>T21</b>

	9.92	
	N 1'	00.19.56
	74	<b>T22</b>

	9.92	
	V 45	00.20.56
	75	<b>T23</b>

LAGO

	10.28	
	V 54	00.21.25
	76	<b>T24</b>







	10.68	
	V 54	00.21.52
	77	<b>T24</b>



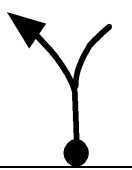
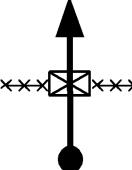

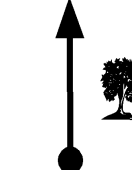
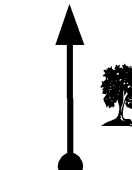

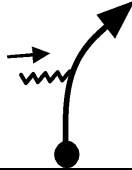
	10.95	
	V 54	00.22.10
	78	<b>T24</b>

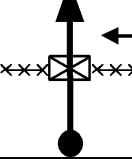
	11.20	
	V 21	00.22.26
	79	<b>T25</b>

	11.52	
	N 1'	00.23.21
	80	<b>T26</b>

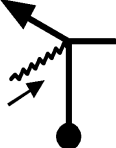

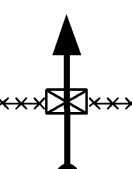
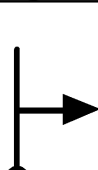

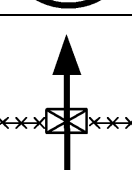
	11.52	
	<b>0.00</b>	
	V 54	00.24.21
	81	<b>T27</b>

	<b>0.39</b>	
	V 54	00.24.47
	82	<b>T27</b>
	<b>0.48</b>	
	V 54	00.24.53
	83	<b>T27</b>
AÇUDE		
SIGA O BAMP		
		
	<b>0.81</b>	
	V 21	00.25.15
	84	<b>T28</b>
	<b>0.90</b>	
	V 21	00.25.31
	85	<b>T28</b>
	<b>0.96</b>	
	V 21	00.25.41
	86	<b>T28</b>
		
	<b>1.10</b>	
	V 45	00.26.05
	87	<b>T29</b>
		
	<b>1.37</b>	
	V 45	00.26.26
	88	<b>T29</b>





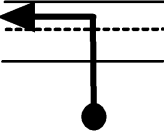
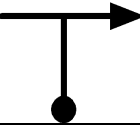
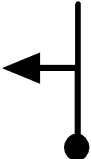
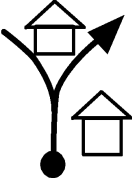

	1.73	
	V 54	00.26.55
	89	<b>T30</b>
		
	2.12	
	V 54	00.27.21
	90	<b>T30</b>
	2.38	
	V 54	00.27.39
	91	<b>T30</b>
	2.62	
	V 54	00.27.55
	92	<b>T30</b>
	2.90	
	V 54	00.28.13
	93	<b>T30</b>
	3.43	
	V 54	00.28.49
	94	<b>T30</b>
	3.54	
	N 2'	00.28.56
	95	<b>T31</b>
	3.54	
	V 15	00.30.56
	96	<b>T32</b>

	<b>3.60</b>	
	V 15	00.31.10
	97	<b>T32</b>
<b>PELO RIO</b>		
	<b>3.68</b>	
	V 15	00.31.30
	98	<b>T32</b>
	<b>3.74</b>	
	D 5'	00.31.44
	99	<b>T33</b>
	<b>5.18</b>	
	100	<b>T33</b>
	<b>5.53</b>	
	V 39	00.36.44
	101	<b>T34</b>
	<b>6.02</b>	
	V 39	00.37.29
	102	<b>T34</b>
	<b>7.46</b>	
	V 39	00.39.42
	103	<b>T34</b>
	<b>7.78</b>	
	V 39	00.40.12
	104	<b>T34</b>

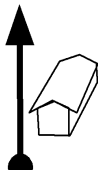
MATA BURRO

	8.56
	V 18 00.41.24
	105 <b>T35</b>
	8.74
	V 18 00.42.00
	106 <b>T35</b>
	8.79
	N 1' 00.42.10
	107 <b>T36</b>
	
	8.79
	0.00
	V 39 00.43.10
108 <b>T37</b>	
	0.41
	V 39 00.43.47
	109 <b>T37</b>
	1.16
	V 18 00.44.57
	110 <b>T38</b>
	1.29
	V 18 00.45.23
	111 <b>T38</b>

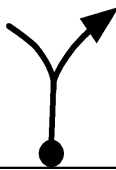
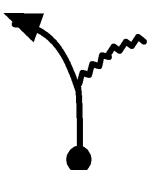
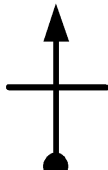







PAIOL	
	1.36
	V 39 00.45.37
	112 <b>T39</b>
	1.84
	N 1' 00.46.21
	113 <b>T40</b>
POR DENTRO	
	1.84
	V 36 00.47.21
	114 <b>T41</b>
	1.89
	V 36 00.47.26
	115 <b>T41</b>
	1.96
	V 36 00.47.33
	116 <b>T41</b>
	2.15
	V 36 00.47.52
	117 <b>T41</b>
	2.39
	V 36 00.48.16
	118 <b>T41</b>
	2.48
	V 24 00.48.25
	119 <b>T42</b>

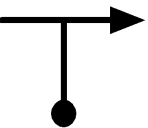

	2.53
	V 24 00.48.32
	120 T42
	2.76
	V 24 00.49.07
	121 T42
	2.84
	V 24 00.49.19
	122 T42
	2.86
	V 33 00.49.22
	123 T43
	2.98
	V 33 00.49.35
	124 T43
	3.08
	V 33 00.49.46
	125 T43
	3.58
	V 33 00.50.40
	126 T43

	3.64	
	V 33	00.50.47
	127	<b>T43</b>
	3.88	
	V 33	00.51.13
	128	<b>T43</b>
	3.95	
	V 21	00.51.21
	129	<b>T44</b>
	4.58	
	V 21	00.53.09
	130	<b>T44</b>
	4.75	
	V 21	00.53.38
	131	<b>T44</b>
	5.59	
	V 33	00.56.02
	132	<b>T45</b>
	6.49	
	V 39	00.57.40
	133	<b>T46</b>
	7.08	
	N 3'	00.58.35
	134	<b>T47</b>

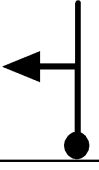
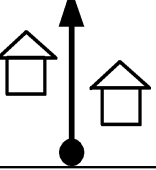
☠☠	
	7.08
	V 39 01.01.35
	135 <b>T48</b>
FINAL DO ASFALTO	
	7.92
	V 39 01.02.52
	136 <b>T48</b>
PELA DIREITA	
	8.05
	V 21 01.03.04
	137 <b>T49</b>
PELA ESQUERDA	
☠	
	8.36
	V 21 01.03.57
	138 <b>T49</b>
	8.74
	V 18 01.05.02
	139 <b>T50</b>
☠☠☠	
	9.33
	V 18 01.07.00
	140 <b>T50</b>
	9.40
	V 18 01.07.14
	141 <b>T50</b>

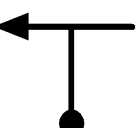
	9.50	
	V 18	01.07.34
	142	<b>T50</b>
	9.54	
	V 15	01.07.42
	143	<b>T51</b>
	9.93	
	<b>0.00</b>	
	V 36	01.09.16
	144	<b>T52</b>
	0.35	
	V 36	01.09.51
	145	<b>T52</b>
	0.46	
	V 18	01.10.02
	146	<b>T53</b>
	0.50	
	V 42	01.10.10
	147	<b>T54</b>
	0.74	
	V 42	01.10.31
	148	<b>T54</b>
	2.07	
	V 42	01.12.25
	149	<b>T54</b>

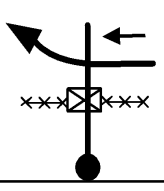
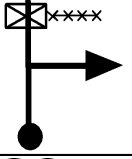
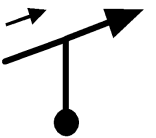
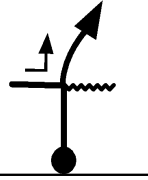
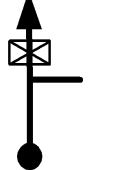
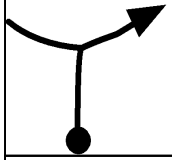
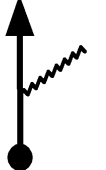
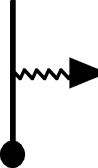

	2.35	V 9	01.12.49
	150	<b>T55</b>	
	2.67	N 2'	01.14.57
	151	<b>T56</b>	
	2.67	V 21	01.16.57
	152	<b>T57</b>	
	2.83	V 30	01.17.24
	153	<b>T58</b>	
	3.25	V 27	01.18.14
	154	<b>T59</b>	
	3.44	V 27	01.18.40
	155	<b>T59</b>	
	3.46	V 27	01.18.42
	156	<b>T59</b>	
	3.53	V 27	01.18.52
	157	<b>T59</b>	

☠☠			3.72
V 27	01.19.17		
158	<b>T59</b>		
		4.05	
		V 27	01.20.01
		159	<b>T59</b>
☠☠			4.26
V 27	01.20.29		
160	<b>T59</b>		
☠☠			4.32
V 27	01.20.37		
161	<b>T59</b>		
		4.65	
		V 27	01.21.21
		162	<b>T59</b>
		4.80	
		V 27	01.21.41
		163	<b>T59</b>
		5.02	
		V 27	01.22.10
		164	<b>T59</b>
		5.12	
		V 27	01.22.24
		165	<b>T59</b>

	
	<b>5.63</b>
	V 27 01.23.32
	166 <b>T59</b>
	
	<b>5.70</b>
	V 27 01.23.41
	167 <b>T59</b>
	<b>6.02</b>
	V 27 01.24.24
	168 <b>T59</b>
	<b>6.17</b>
	V 27 01.24.44
	169 <b>T59</b>
PELA ESQUERDA	
ATOLEIRO	
	
	<b>6.23</b>
	V 27 01.24.52
	170 <b>T59</b>
DESCE	
	<b>6.33</b>
	V 27 01.25.05
	171 <b>T59</b>
	<b>6.44</b>
	N 1' 01.25.20
	172 <b>T60</b>



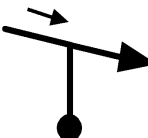
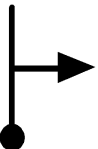
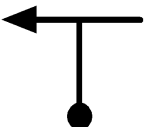

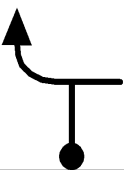
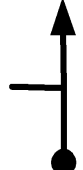
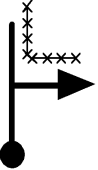

	6.44
	V 42 01.26.20
	173 <b>T61</b>
	6.93
	V 42 01.27.02
	174 <b>T61</b>
	7.30
	V 42 01.27.33
	175 <b>T61</b>
	7.69
	V 42 01.28.07
	176 <b>T61</b>
	7.96
	V 36 01.28.30
	177 <b>T62</b>
<b>CUIDADO</b>	
	8.51
	V 36 01.29.25
	178 <b>T62</b>
	8.55
	V 36 01.29.29
	179 <b>T62</b>
	8.59
	V 36 01.29.33
	180 <b>T62</b>

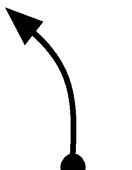
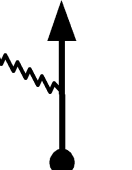
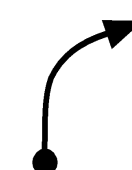
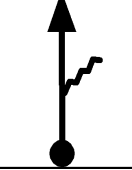
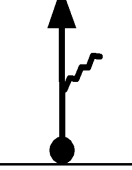
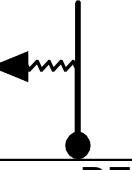
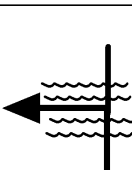
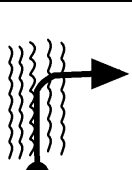

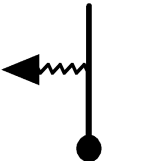

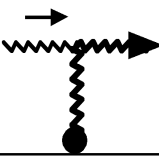
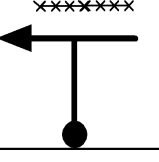
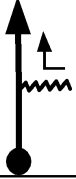
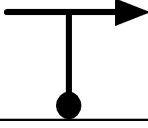

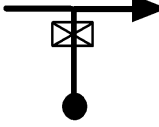

	
	<b>8.65</b>
	V 36 01.29.39
	181 <b>T62</b>
	<b>8.69</b>
	V 36 01.29.43
	182 <b>T62</b>
	<b>8.72</b>
	V 36 01.29.46
	183 <b>T62</b>
	<b>8.78</b>
	V 36 01.29.52
	184 <b>T62</b>
	<b>9.24</b>
	N 1' 01.30.38
	185 <b>T63</b>
	<b>9.24</b>
	V 36 01.31.38
	186 <b>T64</b>
	<b>9.52</b>
	V 36 01.32.06
	187 <b>T64</b>
	<b>9.95</b>
	V 42 01.32.49
	188 <b>T65</b>

BAMP

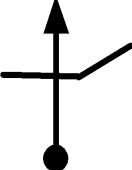
	10.34	
	V 24	01.33.22
	189	<b>T66</b>
	10.41	
	V 24	01.33.33
	190	<b>T66</b>
	10.43	
	V 24	01.33.36
	191	<b>T66</b>
	10.47	
	V 24	01.33.42
	192	<b>T66</b>
	10.53	
	V 24	01.33.51
	193	<b>T66</b>
	10.56	
	V 9	01.33.55
	194	<b>T67</b>
PELO RIO		
	10.58	
	V 9	01.34.03
	195	<b>T67</b>
	10.60	
	V 9	01.34.11
	196	<b>T67</b>



	10.62	
	V 9	01.34.19
	197	<b>T67</b>
SEGUIR A PISTA		
		
	10.63	
	V 45	01.34.23
	198	<b>T68</b>
	10.91	
	V 45	01.34.46
	199	<b>T68</b>
	11.84	
	V 45	01.36.00
	200	<b>T68</b>
	12.12	
	V 45	01.36.23
	201	<b>T68</b>
FINAL		
PRIMEIRA		
PARTE		
	12.17	
	N 18'	01.36.27
	202	<b>T69</b>
	12.17	
	<b>0.00</b>	
	V 39	01.54.27
203	<b>T70</b>	

FINAL DO ASFALTO



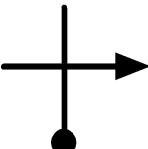

	1.64
	V 39 01.56.58
	204 T70
	1.71
	V 39 01.57.05
	205 T70
	1.79
	V 39 01.57.12
	206 T70
	1.87
	V 39 01.57.19
	207 T70
	2.04
	V 39 01.57.35
	208 T70
	2.31
	V 39 01.58.00
	209 T70
	2.63
	V 15 01.58.29
	210 T71
	2.80
	V 39 01.59.10
	211 T72

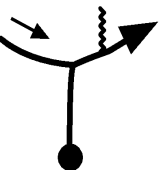
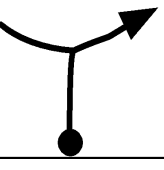
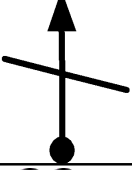
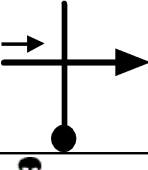
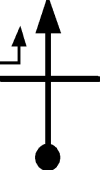
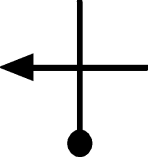



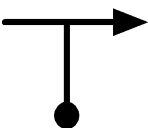

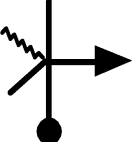
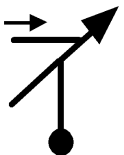

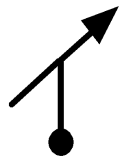
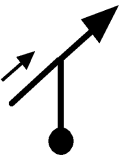
	2.85
	V 39 01.59.15
	212 T72
	3.21
	V 39 01.59.48
	213 T72
	3.44
	V 21 02.00.09
	214 T73
X(9)	
	3.62
	V 36 02.00.40
	215 T74
	3.91
	V 36 02.01.09
	216 T74
X(9)	
	3.96
	V 36 02.01.14
	217 T74
	4.09
	V 36 02.01.27
	218 T74
	4.20
	V 30 02.01.38
	219 T75

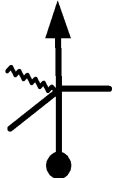





	4.30	
	V 30	02.01.50
	220	<b>T75</b>
	4.38	
	V 30	02.02.00
	221	<b>T75</b>
	4.45	
	V 27	02.02.08
	222	<b>T76</b>
	4.49	
	V 27	02.02.13
	223	<b>T76</b>
	4.75	
	V 27	02.02.48
	224	<b>T76</b>
	4.83	
	N 1'	02.02.59
	225	<b>T77</b>
	4.83	
	V 36	02.03.59
	226	<b>T78</b>
	5.08	
	V 36	02.04.24
	227	<b>T78</b>



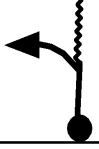

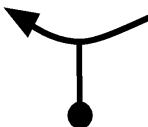
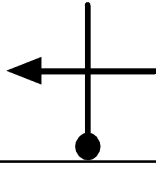

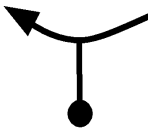
	<b>5.17</b>	
	V 36	02.04.33
	228	<b>T78</b>
	<b>5.42</b>	
	V 36	02.04.58
	229	<b>T78</b>
☠☠		
	<b>5.64</b>	
	V 36	02.05.20
	230	<b>T78</b>
	<b>5.75</b>	
	V 36	02.05.31
	231	<b>T78</b>
	<b>5.87</b>	
	V 36	02.05.43
	232	<b>T78</b>
☠☠		
	<b>6.00</b>	
	V 36	02.05.56
	233	<b>T78</b>
☠		
	<b>6.07</b>	
	V 36	02.06.03
	234	<b>T78</b>
	<b>6.42</b>	
	V 36	02.06.38
	235	<b>T78</b>

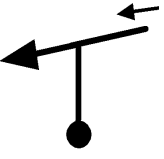

	6.55	
	V 36	02.06.51
	236	<b>T78</b>
X(6)		
	6.64	
	V 36	02.07.00
	237	<b>T78</b>
	6.67	
	V 30	02.07.03
	238	<b>T79</b>
☠☠		
	7.44	
	V 36	02.08.35
	239	<b>T80</b>
		
	7.73	
	V 27	02.09.04
	240	<b>T81</b>
	8.27	
	V 27	02.10.16
	241	<b>T81</b>
X(6)		
	8.29	
	V 27	02.10.19
	242	<b>T81</b>

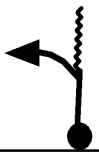
	8.32	
	V 33	02.10.23
	243	<b>T82</b>
	8.39	
	N 1'	02.10.30
	244	<b>T83</b>
	8.39	
	V 33	02.11.30
	245	<b>T84</b>
	8.54	
	V 33	02.11.47
	246	<b>T84</b>
	8.88	
	V 36	02.12.24
	247	<b>T85</b>
	9.36	
	V 36	02.13.12
	248	<b>T85</b>
	9.46	
	V 36	02.13.22
	249	<b>T85</b>
		
	9.85	
	V 36	02.14.01
	250	<b>T85</b>

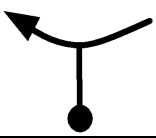
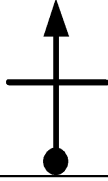





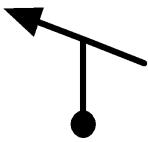
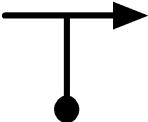

	10.08	
	V 36	02.14.24
	251	<b>T85</b>
	10.19	
	V 36	02.14.35
	252	<b>T85</b>
	10.22	
	V 36	02.14.38
	253	<b>T85</b>
	10.61	
	V 36	02.15.17
	254	<b>T85</b>
	10.69	
	V 36	02.15.25
	255	<b>T85</b>
	10.98	
	V 18	02.15.54
	256	<b>T86</b>
	11.37	
	V 39	02.17.12
	257	<b>T87</b>
	11.52	
	V 39	02.17.26
	258	<b>T87</b>

	
	<b>11.83</b>
	<b>0.00</b>
	V 36 02.17.54
	259 <b>T88</b>
	<b>0.23</b>
	V 36 02.18.17
	260 <b>T88</b>
	<b>0.33</b>
	V 36 02.18.27
	261 <b>T88</b>
	<b>0.36</b>
	V 36 02.18.30
	262 <b>T88</b>
	<b>0.75</b>
	N 1' 02.19.09
	263 <b>T89</b>
	<b>0.75</b>
	V 27 02.20.09
	264 <b>T90</b>
	<b>0.82</b>
	V 27 02.20.19
	265 <b>T90</b>
	<b>0.95</b>
	V 27 02.20.36
	266 <b>T90</b>

	<b>1.05</b>	
	V 27	02.20.49
	267	<b>T90</b>
	<b>1.24</b>	
	V 27	02.21.15
	268	<b>T90</b>
	<b>1.56</b>	
	V 30	02.21.57
	269	<b>T91</b>
	<b>1.76</b>	
	V 30	02.22.21
	270	<b>T91</b>
	<b>2.17</b>	
	V 30	02.23.11
	271	<b>T91</b>
	<b>2.37</b>	
	V 39	02.23.35
	272	<b>T92</b>
	<b>2.87</b>	
	V 39	02.24.21
	273	<b>T92</b>
	<b>3.17</b>	
	V 39	02.24.48
	274	<b>T92</b>

	3.52	
	V 24	02.25.21
	275	<b>T93</b>
<del>X(6)</del> <del>X(6)</del>		
	3.60	
	V 24	02.25.33
	276	<b>T93</b>
<del>X(6)</del> <del>X(6)</del>		
	3.69	
	V 24	02.25.46
	277	<b>T93</b>
	3.75	
	V 24	02.25.55
	278	<b>T93</b>
	3.87	
	V 24	02.26.13
	279	<b>T93</b>
	4.04	
	V 30	02.26.39
	280	<b>T94</b>
	4.25	
	V 30	02.27.04
	281	<b>T94</b>
	4.35	
	V 30	02.27.16
	282	<b>T94</b>

	4.74	
	V 36	02.28.03
	283	<b>T95</b>
	4.89	
	V 27	02.28.18
	284	<b>T96</b>
	4.94	
	V 27	02.28.24
	285	<b>T96</b>
	5.00	
	V 27	02.28.32
	286	<b>T96</b>
	5.06	
	V 27	02.28.40
	287	<b>T96</b>
	5.22	
	V 27	02.29.02
	288	<b>T96</b>
	5.40	
	N 1'	02.29.26
	289	<b>T97</b>
	5.40	
	V 36	02.30.26
	290	<b>T98</b>

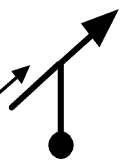
	5.65	
	V 30	02.30.51
	291	<b>T99</b>
	5.79	
	V 30	02.31.08
	292	<b>T99</b>
	5.82	
	V 30	02.31.11
	293	<b>T99</b>
		
	5.91	
	V 30	02.31.22
	294	<b>T99</b>
	5.96	
	V 42	02.31.28
	295	<b>T100</b>
	6.03	
	V 42	02.31.34
	296	<b>T100</b>
	6.48	
	V 24	02.32.13
	297	<b>T101</b>
		
	6.66	
	V 24	02.32.40
	298	<b>T101</b>



	<b>7.02</b>	
	V 30	02.33.34
	299	<b>T102</b>



	<b>7.32</b>	
	V 24	02.34.10
	300	<b>T103</b>





	<b>7.53</b>	
	V 24	02.34.41
	301	<b>T103</b>





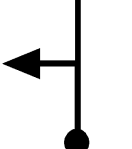
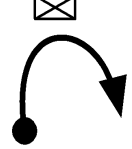

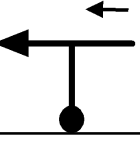
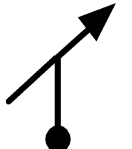
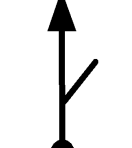
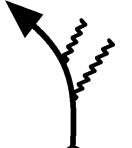

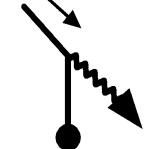
	<b>7.75</b>	
	V 36	02.35.14
	302	<b>T104</b>



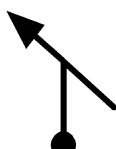

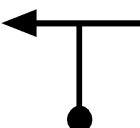
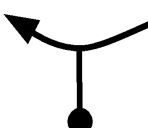
	<b>7.83</b>	
	V 36	02.35.22
	303	<b>T104</b>





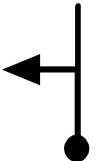
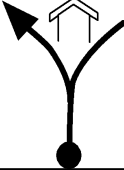

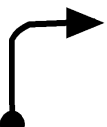
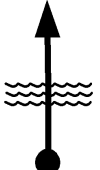

	<b>8.09</b>	
	V 30	02.35.48
	304	<b>T105</b>

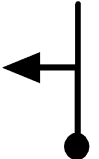
	<b>8.22</b>	
	V 30	02.36.04
	305	<b>T105</b>

	8.25
	V 30 02.36.07
	306 <b>T105</b>
	8.40
	V 30 02.36.25
	307 <b>T105</b>
	8.55
	N1'30s 02.36.43
	308 <b>T106</b>
	8.55
	V 30 02.38.13
	309 <b>T107</b>
	8.60
	V 42 02.38.19
	310 <b>T108</b>
	8.68
	V 42 02.38.26
	311 <b>T108</b>
	9.12
	V 36 02.39.04
	312 <b>T109</b>
	
	9.36
	V 24 02.39.28
	313 <b>T110</b>

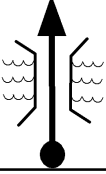
	
	<b>9.44</b>
	V 24 02.39.40
	314 <b>T110</b>
	<b>9.79</b>
	V 24 02.40.32
	315 <b>T110</b>
	
	<b>9.92</b>
	V 24 02.40.52
	316 <b>T110</b>
	<b>10.14</b>
	<b>0.00</b>
	V 39 02.41.25
	317 <b>T111</b>
<b>MUITO CUIDADO - MOTO CONTRA</b>	
<b>MOTO CONTRA</b>	
	
	<b>0.17</b>
	V 39 02.41.40
	318 <b>T111</b>
	<b>0.51</b>
	V 39 02.42.12
	319 <b>T111</b>

	<b>0.65</b>	
	V 30	02.42.25
	320	<b>T112</b>
	<b>0.67</b>	
	V 30	02.42.27
	321	<b>T112</b>
	<b>0.78</b>	
	V 30	02.42.40
	322	<b>T112</b>
	<b>1.11</b>	
	V 24	02.43.20
	323	<b>T113</b>
	<b>1.15</b>	
	V 24	02.43.26
	324	<b>T113</b>
RIO		
	<b>1.20</b>	
	V 24	02.43.34
	325	<b>T113</b>
	<b>1.28</b>	
	V 27	02.43.46
	326	<b>T114</b>
	<b>1.41</b>	
	V 27	02.44.03
	327	<b>T114</b>

	1.46	
	V 27	02.44.10
	328	<b>T114</b>
	1.60	
	V 27	02.44.28
	329	<b>T114</b>
	1.77	
	V 27	02.44.51
	330	<b>T114</b>
	1.86	
	V 42	02.45.03
	331	<b>T115</b>
	1.95	
	V 42	02.45.11
	332	<b>T115</b>
	2.30	
	N 1'	02.45.41
	333	<b>T116</b>
	2.30	
	V 18	02.46.41
	334	<b>T117</b>
	2.33	
	V 18	02.46.47
	335	<b>T117</b>

	2.42
	V 42 02.47.05
	336 <b>T118</b>
	2.75
	V 42 02.47.33
	337 <b>T118</b>
	2.90
	V 21 02.47.46
	338 <b>T119</b>
	3.00
	V 24 02.48.03
	339 <b>T120</b>
CUIDADO	
ATOLEIRO	
	3.24
	V 21 02.48.39
	340 <b>T121</b>
	3.28
	V 21 02.48.46
	341 <b>T121</b>
	3.87
	V 21 02.50.27
	342 <b>T121</b>
	3.90
	V 39 02.50.32
	343 <b>T122</b>

	5.41	
	V 39	02.52.51
	344	<b>T122</b>
	6.19	
	V 39	02.54.03
	345	<b>T122</b>
	6.26	
	V 21	02.54.10
	346	<b>T123</b>
	6.57	
	V 24	02.55.03
	347	<b>T124</b>
	6.92	
	V 24	02.55.55
	348	<b>T124</b>
	7.11	
	V 39	02.56.24
	349	<b>T125</b>
	7.49	
	V 24	02.56.59
	350	<b>T126</b>
BAMP		
	7.60	
	V 24	02.57.16
	351	<b>T126</b>

	<b>7.73</b>	
	V 36	02.57.35
	352	<b>T127</b>
	<b>7.75</b>	
	V 36	02.57.37
	353	<b>T127</b>
	<b>8.18</b>	
	V 42	02.58.20
	354	<b>T128</b>
BAMP		
	<b>8.56</b>	
	V 24	02.58.53
	355	<b>T129</b>
	<b>8.69</b>	
	V 24	02.59.12
	356	<b>T129</b>
	<b>8.75</b>	
	V 24	02.59.21
	357	<b>T129</b>
	<b>8.79</b>	
	V 9	02.59.27
	358	<b>T130</b>
SIGA PELO RIO		
	<b>8.81</b>	
	V 9	02.59.35
	359	<b>T130</b>



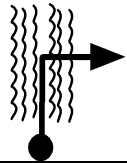

8.82

V 9 02.59.39

360 T130

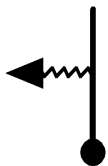

8.83

V 9 02.59.43

361 T130

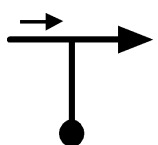

8.84

V 45 02.59.47

362 T131

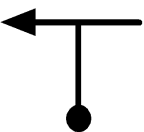

9.13

V 45 03.00.10

363 T131

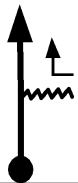

10.05

V 45 03.01.24

364 T131

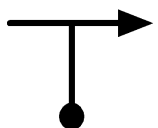

10.33

V 45 03.01.46

365 T131

**FIM DE PROVA !!**



[www.t15.com.br](http://www.t15.com.br)

A EQUIPE BICHO DO MATO  
AGRADECE O SEU  
COMPARECIMENTO.

**Tempo de Prova**

OVER 40/JUNIOR 03:01:46

**FIM**