

INICIO

MÉDIA B

11º ENDURO DO CARVÃO
16 DE MARÇO DE 2019



IMPORTANTE

 CUIDADO

 ATENÇÃO

 MUITA ATENÇÃO

Tempo de Prova

MÉDIA B 02:50:03



AFERIÇÃO

ZERAR NA PARADA

DE ONIBUS

0.00

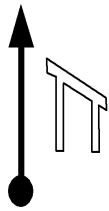

AFER

1

LOMBADA

0.05



AFER

2

LOMBADA

0.21



AFER

3

0.48

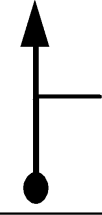

AFER

4

0.95

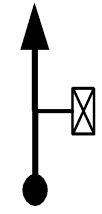

AFER

5

1.25

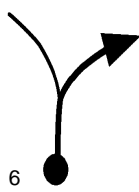

AFER

6

RÓTULA

1.39



AFER

7

1.44

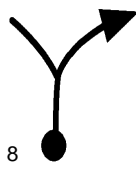

AFER 8

AFERIR NO FINAL
DO ASFALTO

1.65

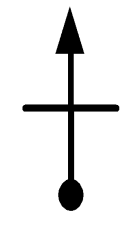

0.00

AFER 9



INICIO DE PROVA

ZERAR NA
PARADA DE ONIBUS

0.00

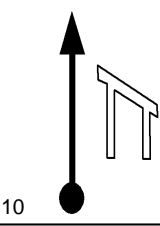

V 30 00.00.00

T1 10

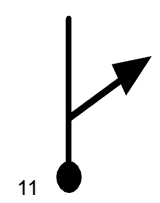
0.18	
V 30 00.00.22	
T1	11

FINAL DA LAJOTA

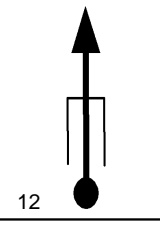
0.56	
V 30 00.01.07	
T1	12

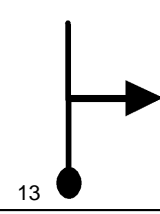
0.97	
V 30 00.01.56	
T1	13

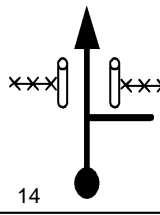
1.08	
V 25 00.02.10	
T2	14

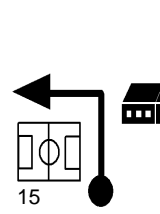
1.17	
V 25 00.02.23	
T2	15

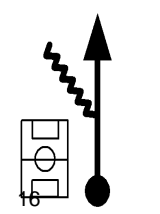
1.28	
V 25 00.02.38	
T2	16

1.30

V 25 00.02.41

T2 17

1.43

V 19 00.03.00

T3 18

PELA ESQUERDA
DO BAMPI

1.44

V 19 00.03.02

T3 19

MUITO CUIDADO
MOTOS CONTRA

1.53

V 27 00.03.19

T4 20

1.54

V 27 00.03.20

T4 21

1.56

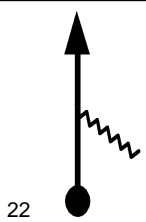

22

V 27 00.03.23

T4

1.65

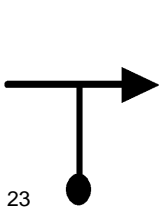

23

V 27 00.03.35

T4

1.69

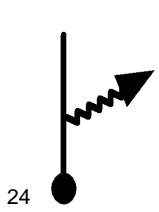

24

V 27 00.03.40

T4

1.73

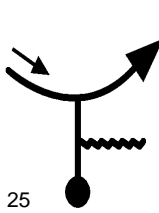

25

V 27 00.03.46

T4

1.84

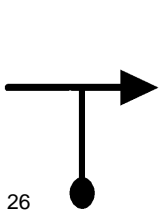

26

V 27 00.04.00

T4

1.89

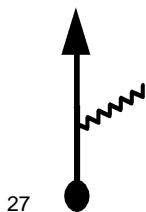

27

V 27 00.04.07

T4

1.93	xxxxxxxxx ↓ →
V 19 00.04.12	
T5	28

PELA ESQUERDA

DO BAMPI

MOTOS CONTRA

1.95	↑ ↓ ↓ ↗
V 19 00.04.16	
T5	29

2.03	x x x x x ↓ ← x x x x x ↓
V 33 00.04.31	
T6	30

COSTEANDO

O MATO

2.04	↑ ↓ ↓ ↓ ↓ ↓
V 33 00.04.32	
T6	31

2.17	→ ↗ ↑
V 33 00.04.46	
T6	32

COSTEAR O MATO

2.25

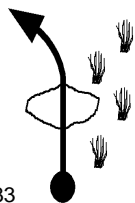

33

V 33 00.04.55

T6

2.32

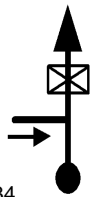

34

V 33 00.05.03

T6

2.65



35

V 33 00.05.39

T6

2.72



36

V 33 00.05.46

T6

2.89

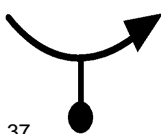

37

V 33 00.06.05

T6

3.16



38

V 33 00.06.34

T6

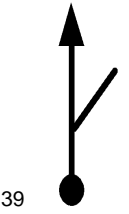
3.21	
V 33 00.06.40	
T6	39

COSTEAR O VALO

SIGA BUMPIS

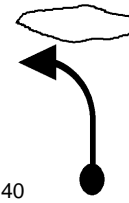
3.40	
V 33 00.07.01	
T6	40

VALO

3.46	
V 33 00.07.07	
T6	41

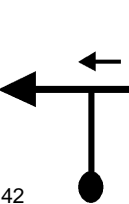
3.50	
V 33 00.07.12	
T6	42

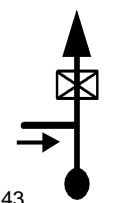
3.66	
V 36 00.07.29	
T7	43

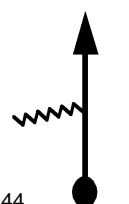
3.99	
V 36 00.08.02	
T7	44

4.06

V 36 00.08.09
T7

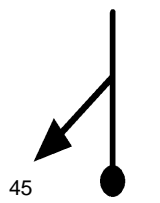

45

COSTEAR O MATO

4.22

V 36 00.08.25
T7

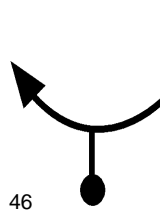

46

4.54

V 36 00.08.57
T7

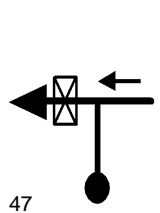

47

4.87

V 36 00.09.30
T7

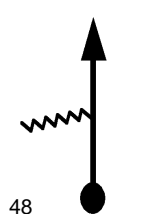

48

4.94

V 36 00.09.37
T7

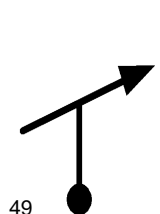

49

5.21

V 36 00.10.04
T7

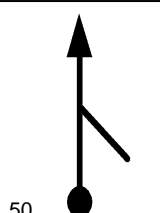

50

5.24	
N 2' 00.10.07	
T8	51

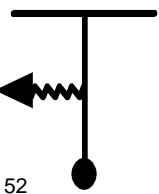
5.24	
V 22 00.12.07	
T9	52

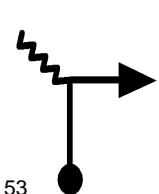
5.32	
V 22 00.12.20	
T9	53

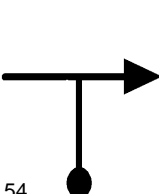
5.42	
V 22 00.12.36	
T9	54

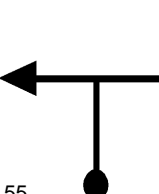
5.55	
V 24 00.12.58	
T10	55

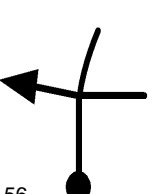
5.85	
V 24 00.13.43	
T10	56

FINAL DO ASFALTO

5.94



V 24 00.13.56

T10

57

COLINA DO AVIVAMENTO

6.64



V 24 00.15.41

T10

58

7.76



V 24 00.18.29

T10

59



8.04

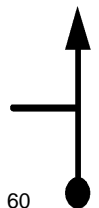

V 24 00.19.11

T10

60

CUIDADO - VALO

8.89

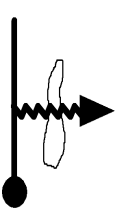

V 19 00.21.19

T11

61

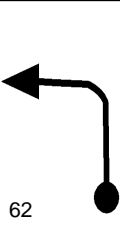
9.15	
V 19 00.22.08	
T11	62

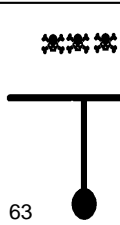
9.25	
V 33 00.22.27	
T12	63

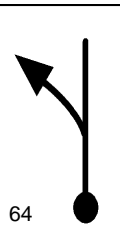
9.40	
V 33 00.22.43	
T12	64

10.00	
V 23 00.23.49	
T13	65

BANHADO

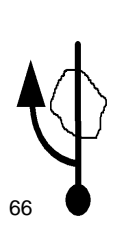
10.31	
V 19 00.24.37	
T14	66

10.60	
V 19 00.25.32	
T14	67

10.69
V 19 00.25.49
T14 68

10.85
V 19 00.26.20
T14 69

10.89
V 19 00.26.27
T14 70

10.93
V 17 00.26.35
T15 71

11.01
V 17 00.26.52
T15 72

11.05
V 17 00.27.00
T15 73

11.08	
V 17 00.27.07	
T15	74

11.25	
N2'50s 00.27.43	
T16	75

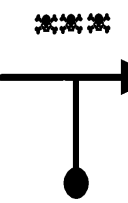
11.25	
0.00	
V 33 00.30.33	
T17	76

PELO ACOSTAMENTO

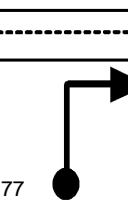
0.55	
V 33 00.31.33	
T17	77

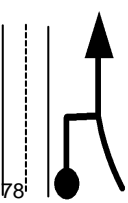
0.80	
V 30 00.32.00	
T18	78

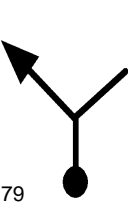
0.85	
V 30 00.32.06	
T18	79

ACELERAAAAA!!

0.98

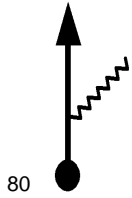

80

V 30 00.32.21

T18

1.29

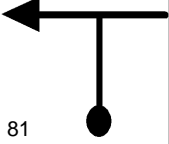

81

V 30 00.32.59

T18

BANHADO

1.36

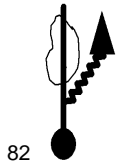

82

V 33 00.33.07

T19

1.61

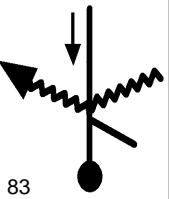

83

V 17 00.33.34

T20

1.78

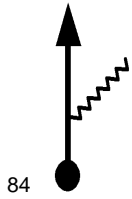

84

V 33 00.34.10

T21



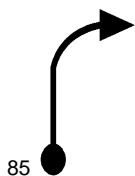

2.16

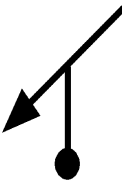

85

V 33 00.34.52

T21

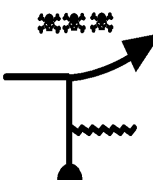
2.22	
N 2' 00.34.58	
T22	86
2.22	
V 27 00.36.58	
T23	87
2.30	
V 10 00.37.09	
T24	88
2.40	
V 16 00.37.45	
T25	89
2.44	
V 16 00.37.54	
T25	90
2.84	
V 36 00.39.24	
T26	91

3.20

V 47 00.40.00

T27

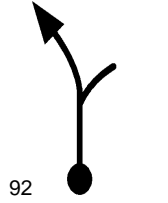

92

5.25

V 37 00.42.37

T28

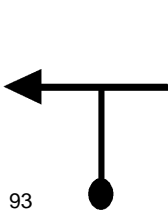

93

5.83

V 37 00.43.33

T28

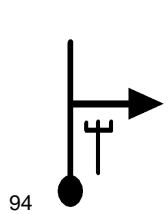

94

5.87

V 21 00.43.37

T29

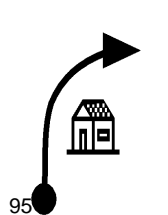

95

6.04

V 21 00.44.06

T29

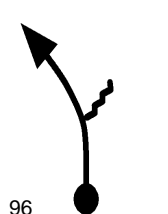

96

6.15

V 30 00.44.25

T30

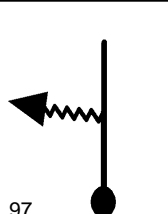

97

6.67

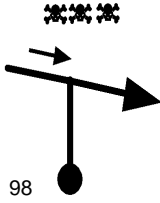

V 24 00.45.28

T31

98

SUBA

6.75

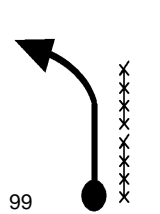

V 24 00.45.40

T31

99

6.80

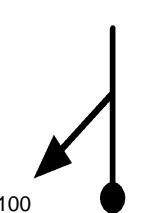

V 24 00.45.47

T31

100

DESÇA COM CUIDADO

BUMP

6.94

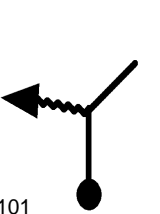

V 10 00.46.08

T32

101

6.96

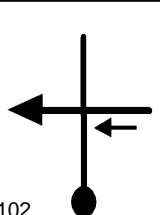

V 23 00.46.15

T33

102

SIGA BUMP

6.99

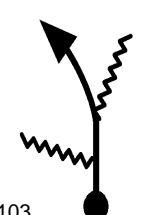

V 23 00.46.20

T33

103

7.03	
V 30 00.46.26	
T34	104

7.09	
V 30 00.46.34	
T34	105

7.16	
V 30 00.46.42	
T34	106

7.23	
V 30 00.46.50	
T34	107

7.45	
V 30 00.47.17	
T34	108

DESÇA

7.54	
V 30 00.47.28	
T34	109

7.57

V 30 00.47.31

T34 110

7.59

V 30 00.47.34

T34 111

7.63

V 30 00.47.38

T34 112

7.70

V 30 00.47.47

T34 113

7.76

V 30 00.47.54

T34 114

7.84

V 30 00.48.04

T34 115

7.99	
N2'50s 00.48.22	
T35	116

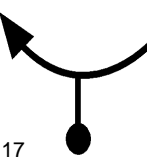
7.99	
V 27 00.51.12	
T36	117

8.15	
V 27 00.51.33	
T36	118

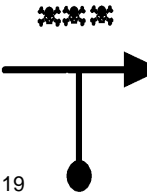
8.26	
V 39 00.51.48	
T37	119

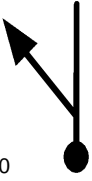

8.28	
V 39 00.51.49	
T37	120

8.39
V 39 00.52.00
T37 121

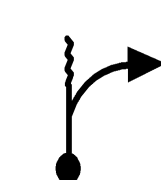

8.87
V 13 00.52.44
T38 122

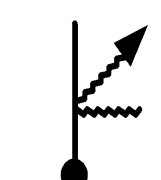

8.96
V 13 00.53.09
T38 123

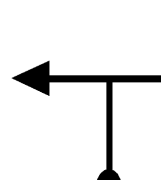

BANHADO

8.97
V 13 00.53.11
T38 124

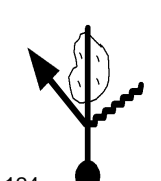

9.00
V 41 00.53.20
T39 125

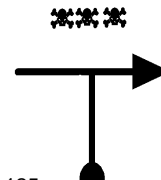

9.44
V 23 00.53.58
T40 126

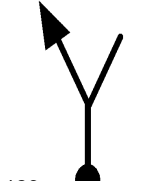

VOCE ESCOLHE

ACELERE !!

9.71

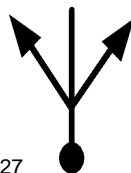

V 23 00.54.41

T40 127

9.86

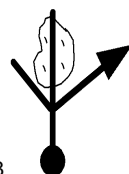

V 23 00.55.04

T40 128

9.91

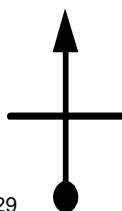

V 23 00.55.12

T40 129

BUMP !!

9.95



V 23 00.55.18

T40 130



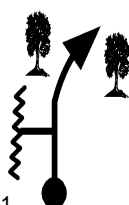

ENTRE AS ÁRVORES

9.99



V 23 00.55.25

T40 131

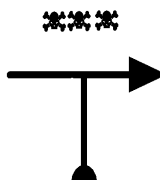
10.00	
V 23 00.55.26	
T40	132
10.01	
V 23 00.55.28	
T40	133
10.04	
V 23 00.55.32	
T40	134
10.14	
V 23 00.55.48	
T40	135
10.19	
N 3' 00.55.56	
T41	136
10.19	
0.00	
V 41 00.58.56	
T42	137

0.61	
V 41 00.59.49	
T42	138

0.71	
V 41 00.59.58	
T42	139

CUIDADO PONTE

0.76	
V 10 01.00.03	
T43	140

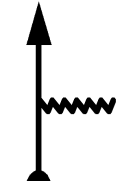
0.88	
V 33 01.00.46	
T44	141

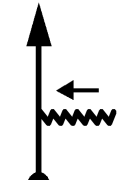
1.25	
V 23 01.01.26	
T45	142

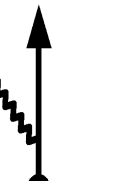
1.34	
V 23 01.01.40	
T45	143

1.40



V 23 01.01.50

T45 144

EROSÃO

1.45



V 23 01.01.57

T45 145

1.53



V 23 01.02.10

T45 146

1.56



V 23 01.02.15

T45 147

1.64

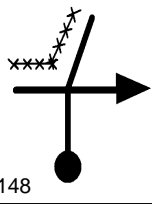

V 37 01.02.27

T46 148

1.77

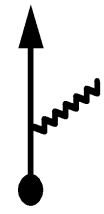

V 37 01.02.40

T46 149

CUIDADO

PONTE

2.15

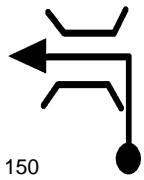

V 21 01.03.17

T47

150

2.22

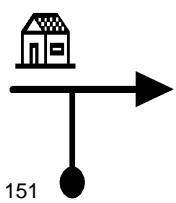

V 21 01.03.29

T47

151

2.35

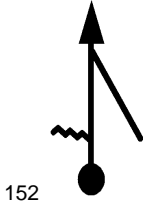

V 20 01.03.51

T48

152

2.43

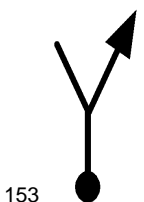

V 30 01.04.05

T49

153

2.83

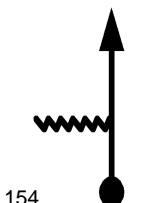

V 30 01.04.53

T49

154

2.95

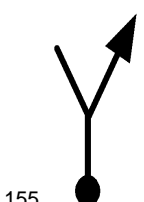

V 20 01.05.08

T50

155

3.23

V 24 01.05.58

T51

156



3.54

V 21 01.06.45

T52

157

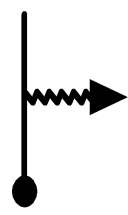

ACELERE

3.94

V 21 01.07.53

T52

158



CUIDADO

MOTOS À ESQUERDA

4.18

V 23 01.08.34

T53

159

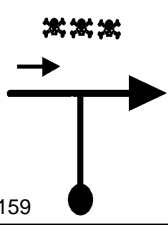

4.27

V 23 01.08.49

T53

160





4.30

V 23 01.08.53

T53

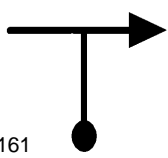
161





4.33	
V 23 01.08.58	
T53	162

CUIDADO

EROSÃO

4.39	
V 23 01.09.07	
T53	163

4.47	
V 23 01.09.20	
T53	164

4.49	
V 23 01.09.23	
T53	165

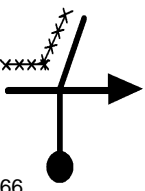
4.57	
V 37 01.09.36	
T54	166

4.70	
V 37 01.09.48	
T54	167

CUIDADO

PONTE

5.08

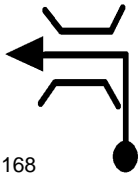

V 20 01.10.25

T55

168

5.16

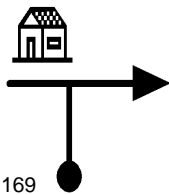

V 20 01.10.40

T55

169

5.29

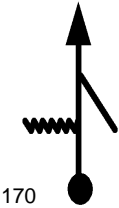

V 20 01.11.03

T55

170

5.36

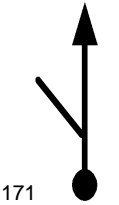

V 30 01.11.16

T56

171

5.77

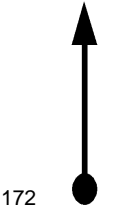

V 23 01.12.05

T57

172

5.87

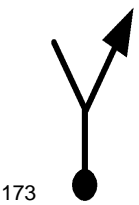

V 23 01.12.20

T57

173

ZERAR NO POSTE

APOIO

5.93



N 18' 01.12.30

T58 174

5.93

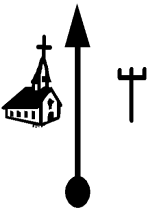

0.00

V 40 01.30.30

T59 175

0.21

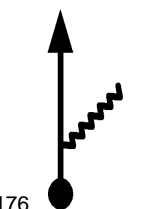

V 40 01.30.49

T59 176

1.33

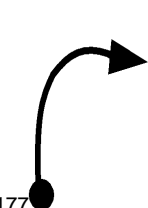

V 40 01.32.29

T59 177

1.45



V 40 01.32.40

T59 178

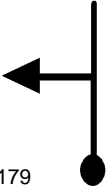
2.29	
V 30 01.33.56	
T60	179

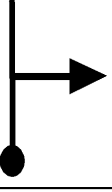

2.39	
V 22 01.34.08	
T61	180

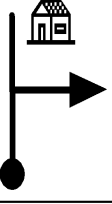
2.67	
V 22 01.34.54	
T61	181

2.71	
V 22 01.35.00	
T61	182

2.76	
V 22 01.35.08	
T61	183

CUIDADO

PEDRA LISA!!

3.10



V 23 01.36.04

T62 184

3.22

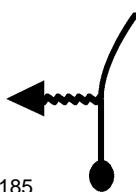

V 23 01.36.23

T62 185

ACELERE

PELO MEIO

3.33



V 21 01.36.40

T63 186

ACELERE

BANHADO

3.44



V 21 01.36.59

T63 187

3.71



V 21 01.37.45

T63 188

ACELERE

BANHADO

3.79



V 21 01.37.59

T63 189

3.86



V 21 01.38.11

T63 190

3.98



V 21 01.38.31

T63 191

ÁRVORE CAÍDA

CUIDADO

4.03



V 21 01.38.40





T63 192

4.16

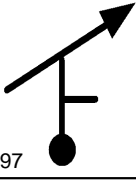

V 21 01.39.02

T63 193

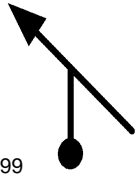
4.25	
V 33 01.39.18	
T64	194
4.53	
V 33 01.39.48	
T64	195
4.61	
N2'50s 01.39.57	
T65	196
4.61	
V 23 01.42.47	
T66	197
4.64	
V 23 01.42.52	
T66	198
4.71	
V 23 01.43.03	
T66	199

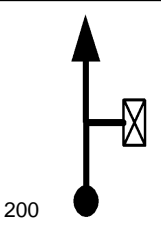
5.22	
V 30 01.44.22	
T67	200

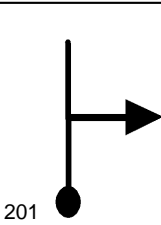
5.51	
V 30 01.44.57	
T67	201

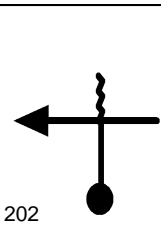
5.52	
V 30 01.44.58	
T67	202

SIGA BUMP

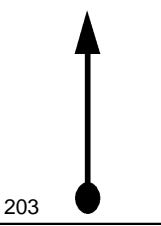
5.59	
V 30 01.45.07	
T67	203

SIGA BUMP

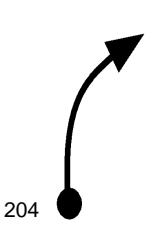
5.69	
V 30 01.45.19	
T67	204

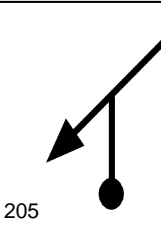
5.74	
V 30 01.45.25	
T67	205

CUIDADOS

MOTOS À DIREITA

5.78

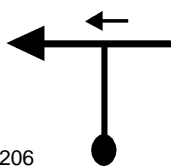

V 30 01.45.30

T67 206

5.81



V 33 01.45.33

T68 207

COSTEAR MATO

5.84



V 33 01.45.37

T68 208

POSTE TBG

5.96



V 33 01.45.50

T68 209

6.03

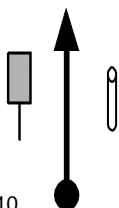

V 33 01.45.57

T68 210

CUIDADO

MOTOS CONTRA

6.04

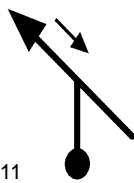

V 23 01.45.58

T69 211

CUIDADO

MOTOS CONTRA

6.24

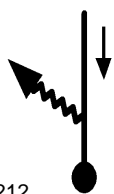

V 23 01.46.30

T69 212

POSTE TBG

6.30



V 23 01.46.39

T69 213

PONTE

6.31

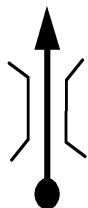

V 23 01.46.41

T69 214

POSTE TBG

6.37

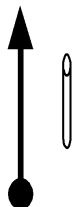

V 23 01.46.50

T69 215

6.39

V 23 01.46.53

T69 216

6.41

V 23 01.46.56

T69 217

6.50

V 15 01.47.10

T70 218

6.98

V 15 01.49.06

T70 219

7.08

V 15 01.49.30

T70 220

7.35

V 24 01.50.34

T71 221

POSTE TBG

7.36



V 24 01.50.36

T71

222

MOTOS CONTRA

7.52

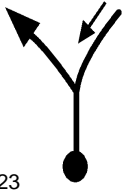

V 24 01.51.00

T71

223

COSTEAR O EUCALIPTO

7.56

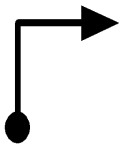

V 24 01.51.06

T71

224

POSTE TBG

7.71



V 24 01.51.28

T71

225

7.72



V 24 01.51.30

T71

226

7.76

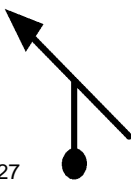

V 33 01.51.36

T72

227

7.87
V 39 01.51.48
T73 228

7.99
V 39 01.51.59
T73 229

8.29
0.00
V 43 01.52.27
T74 230

MOTOS CONTRA

0.41
V 23 01.53.01
T75 231

0.65
V 23 01.53.39
T75 232

0.69
V 27 01.53.45
T76 233

0.82
V 24 01.54.02
T77 234

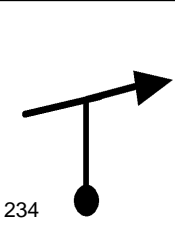

0.92
V 24 01.54.17
T77 235

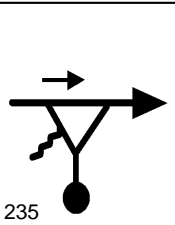

0.95
V 24 01.54.22
T77 236

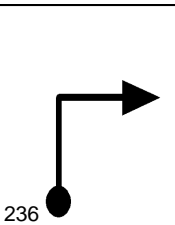

1.11
V 24 01.54.46
T77 237

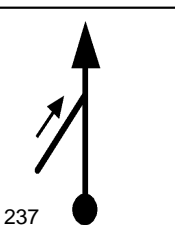

1.16
V 24 01.54.53
T77 238

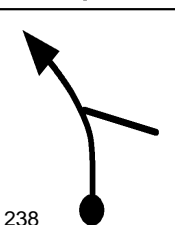

1.26
V 39 01.55.08
T78 239

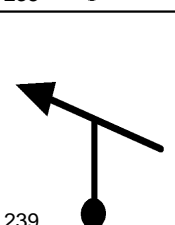



1.38



V 39 01.55.19

T78 240

1.69



N 2' 01.55.48

T79 241

1.69

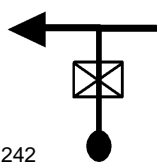

V 43 01.57.48

T80 242

MOTOS CONTRA

2.10

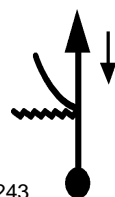

V 43 01.58.22

T80 243

2.15

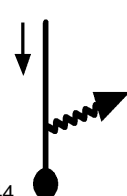

V 12 01.58.26

T81 244

BANHADO

ACELERE

2.41



V 12 01.59.44

T81 245

BANHADO

ACELERE

2.45



V 23 01.59.56

T82 246

2.85

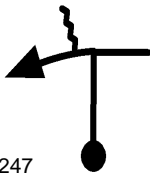

V 33 02.00.59

T83 247

3.00



V 33 02.01.15

T83 248

BUMP

3.06

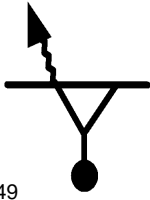

V 33 02.01.22

T83 249

MOTOS CONTRA

3.36



V 33 02.01.55

T83 250

3.56

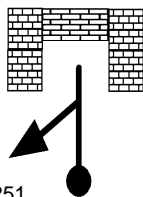

V 21 02.02.16

T84 251

CUIDADO

EUCALIPTO CAÍDO

3.71

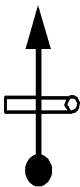

V 21 02.02.42

T84 252

3.72

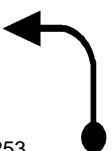

V 15 02.02.44

T85 253

3.82

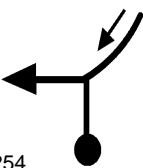

V 33 02.03.08

T86 254

PORTÃO

4.03

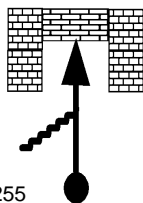

V 33 02.03.31

T86 255

4.05



N 1' 02.03.33

T87

256

4.05

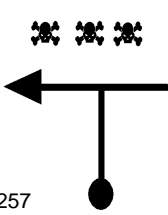

V 33 02.04.33

T88

257

CUIDADO

MOTOS CONTRA

4.70

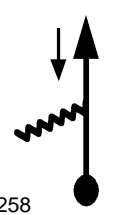

V 33 02.05.44

T88

258

CUIDADO MOTOS

4.73

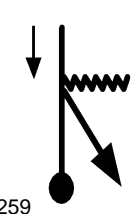

V 33 02.05.47

T88

259

CUIDADO

MOTOS Á DIREITA

4.92

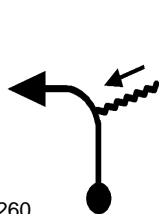

V 33 02.06.08

T88

260

5.19	
V 33 02.06.37	
T88	261

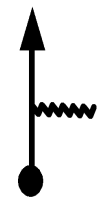
5.45	
V 33 02.07.06	
T88	262

CUIDADO

MOTOS CONTRA

5.66	
V 33 02.07.28	
T88	263

CUIDADO

MOTOS CONTRA

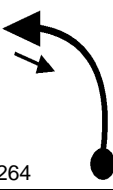
5.75	
V 33 02.07.38	
T88	264

CUIDADO MOTOS

5.86	
V 33 02.07.50	
T88	265

CUIDADO MOTOS

6.14



V 33 02.08.21

T88 266

MOTOS CONTRA

6.68



V 33 02.09.20

T88 267

CUIDADO MOTOS

7.18



V 33 02.10.14

T88 268

7.25



V 33 02.10.22

T88 269

7.48

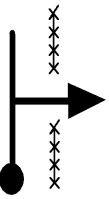

V 27 02.10.47

T89 270

COSTEAR MATO

7.50

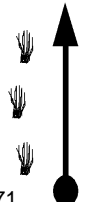

V 27 02.10.50

T89 271

ENTRAR NO MATO

7.60



V 27 02.11.03

T89 272

ACELERA

7.61



V 27 02.11.04

T89 273

COSTEAR MATO

7.64



V 27 02.11.08

T89 274

7.72

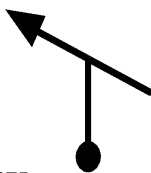

V 27 02.11.19

T89 275

7.74



V 27 02.11.22

T89 276

EROSÃO

7.82



V 27 02.11.32

T89 277

EROSAO

7.88



V 27 02.11.40

T89 278

SIGA BUMP

GRAMADO

7.98



V 27 02.11.54

T89 279

VALO

8.23



V 27 02.12.27

T89 280

8.28



V 27 02.12.34

T89 281

8.31

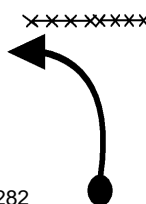

V 25 02.12.38

T90 282

8.33

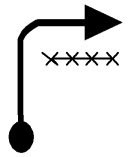

V 25 02.12.41

T90

283

8.43

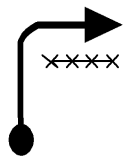

V 25 02.12.55

T90

284

8.56

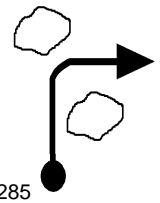

V 25 02.13.14

T90

285

PONTE

8.60

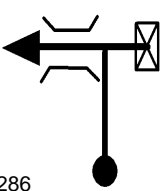

V 25 02.13.19

T90

286

8.62

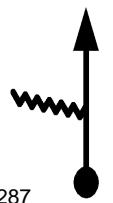

V 25 02.13.22

T90

287

8.67

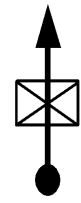

V 25 02.13.30

T90

288

8.78

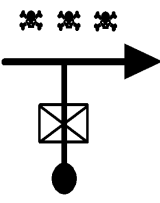

0.00

V 36 02.13.45

T91 289

CUIDADO

0.93

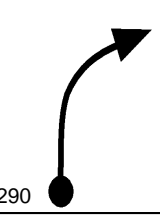

V 36 02.15.18

T91 290

1.09

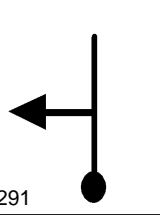

V 36 02.15.34

T91 291

2.05

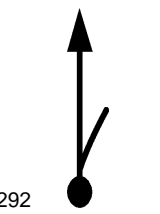

V 33 02.17.10

T92 292

2.55

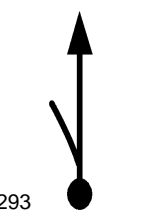

V 12 02.18.05

T93 293

2.66

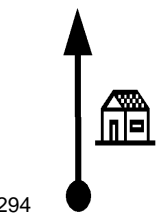

V 12 02.18.38

T93 294

2.70	
V 12 02.18.50	
T93	295

2.72	
V 12 02.18.56	
T93	296

2.74	
V 18 02.19.02	
T94	297

SIGA BUMP

2.78	
V 18 02.19.10	
T94	298

2.80	
V 18 02.19.14	
T94	299



2.84	
V 18 02.19.22	
T94	300

BUMP

2.87

XXXXXXXXXX



V 18 02.19.28

T94

301

CUIDADO

2.89

XXXXXX



V 18 02.19.32

T94

302

ENTRAR NO MATO

2.91



V 19 02.19.36

T95

303

3.42

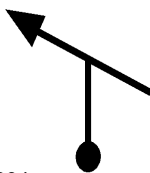

V 19 02.21.13

T95

304

3.48



N 30s 02.21.24

T96

305

3.48

XXXXXX

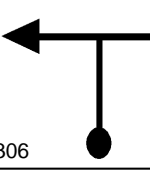

V 33 02.21.54

T97

306

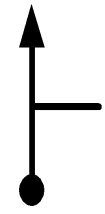
3.85	
V 33 02.22.34	
T97	307

4.78	
V 26 02.24.16	
T98	308

LOMBADA

5.54	
V 26 02.26.01	
T98	309

INICIO DO ASFALTO

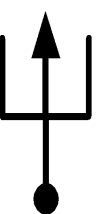
5.97	
V 26 02.27.00	
T98	310

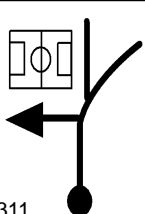
6.04	
V 26 02.27.10	
T98	311

6.16	
V 26 02.27.27	
T98	312

6.89	
V 36 02.29.08	
T99 313	

8.06	
V 36 02.31.05	
T99 314	

8.45	
V 36 02.31.44	
T99 315	

8.76	
V 36 02.32.15	
T99 316	

PELO LADO
DO MONTE DE AREIA

9.63	
V 23 02.33.42	
T100 317	

9.80	
V 23 02.34.08	
T100 318	

9.92	
V 23 02.34.27	
T100	319
9.94	
V 23 02.34.30	
T100	320
10.02	
V 17 02.34.43	
T101	321
10.07	
V 17 02.34.54	
T101	322
10.12	
V 17 02.35.04	
T101	323
10.13	
V 35 02.35.06	
T102	324

CUIDADO COM A CABEÇA
PASSE POR BAIXO DA ARVORE

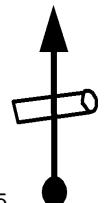
10.62	
V 35 02.35.57	
T102 ³²⁵	

10.74	
V 35 02.36.09	
T102 ³²⁶	

10.89	
V 35 02.36.24	
T102 ³²⁷	

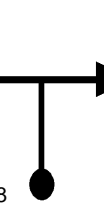
11.09	
V 35 02.36.45	
T102 ³²⁸	

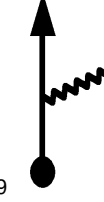
11.22	
V 35 02.36.58	
T102 ³²⁹	

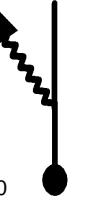
11.25	
V 19 02.37.01	
T103 ³³⁰	

11.48
V 19 02.37.45
T103 331

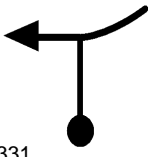

11.56
N 3' 02.38.00
T104 332



11.56
0.00
V 35 02.41.00
T105 333

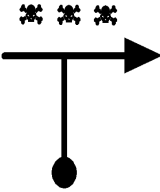

0.42
V 35 02.41.43
T105 334

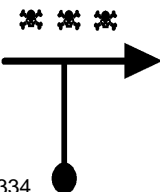

CUIDADO - MOTOS

1.43
V 27 02.43.27
T106 335

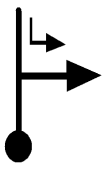

1.56
V 27 02.43.45
T106 336

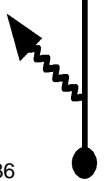

1.64

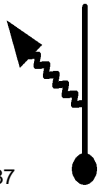

V 27 02.43.55

T106 337

1.73



V 27 02.44.07

T106 338

1.80

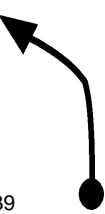

V 27 02.44.17

T106 339

1.85

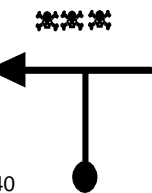

V 35 02.44.23

T107 340

CUIDADO

MOTOS CONTRA

2.01



V 35 02.44.40

T107 341

2.13

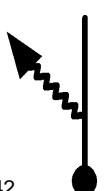

V 35 02.44.52

T107 342

2.21	
V 35 02.45.00	
T107	343
2.37	
V 23 02.45.17	
T108	344
2.46	
V 23 02.45.31	
T108	345
2.52	
V 23 02.45.40	
T108	346
2.54	
V 23 02.45.43	
T108	347
BUMP	
2.59	
V 23 02.45.51	
T108	348

2.62

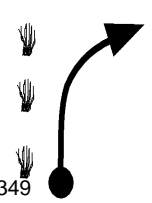

V 23 02.45.56

T108

349

2.67

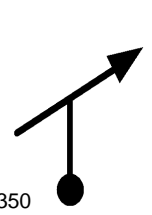

V 23 02.46.04

T108

350

EROSÃO

2.72

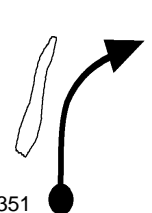

V 23 02.46.11

T108

351

BUMP

2.75

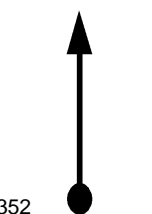

V 23 02.46.16

T108

352

2.87

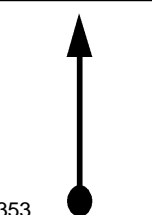

V 23 02.46.35

T108

353

2.89

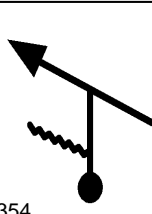

V 33 02.46.38

T109

354

3.15	
V 33 02.47.06	
T109 ³⁵⁵	

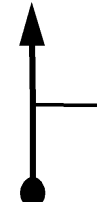
4.29	
V 33 02.49.11	
T109 ³⁵⁶	

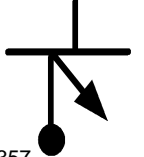
4.70	
V 33 02.49.56	
T109 ³⁵⁷	

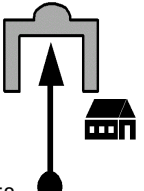
4.77	
V 33 02.50.03	
T109 ³⁵⁸	

FIM DE PROVA !!



www.t15.com.br

Tempo de Prova

MÉDIA B 02:50:03

