

INICIO

MÉDIA A

ENDURO DE IÇARA
11 DE OUTUBRO DE 2018



Trans
Baldissera



IMPORTANTE

Enduro de Içara válido pela 11ª e 12ª Etapas Copa MTC de Regularidade Borilli Raci ng.

Diretores de Prova:

Geovani Bal di ssera
Ademar Si l vei ra
Renato De Souza

Largada: 14: 00Hs

Local : Mi rante da Praia



Neutro pri nci pal Bai rro Urusanga Vel ha/i çara

***Atenção nas
Informações de:***

***Perigo Roça e Estradas.
Você é responsável por qualquer
dano a propriedade alheia
inclusive moradores.***

Chegada no mesmo local da largada

Levantamento da prova
Moto Ktm pneu
di anteiro 121 i bras

 CUIDADO
 ATENÇÃO
 MUITA ATENÇÃO

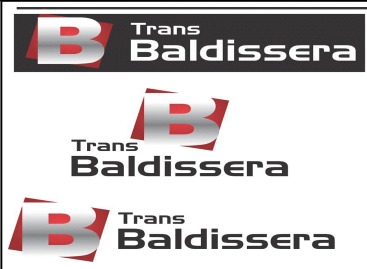

Tempo de Prova

MÉDIA A 02:59:35



AFERIÇÃO

ZERAR NO

PORTAL

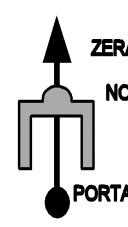
0.00	
AFER	1

AFERIR

DEVAGAR

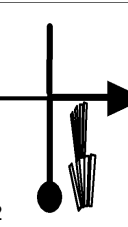
0.03	
AFER	2

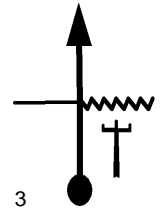
0.29	
AFER	3

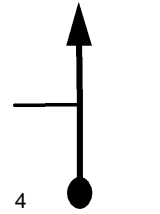
0.37	
AFER	4

DEVAGAR

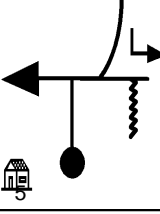
0.45	
AFER	5

ESTRADA

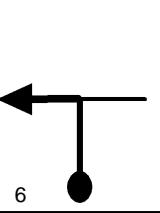
1.02	
AFER	6

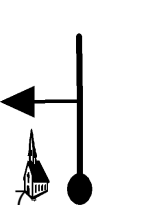
1.10	
AFER	7

CRIANÇAS

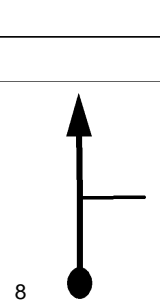
1.49	
AFER	8

CRIANÇAS

1.56

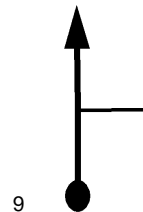

AFER

9

FAVOR

AFERIR

DEVAGAR

1.69

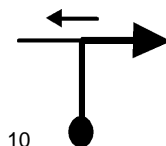

AFER

10

1.77

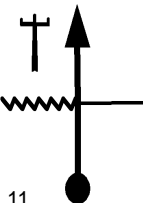

AFER

11

AFERE

2,030

2.03

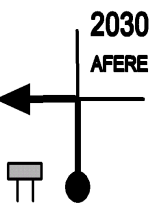

0.00



AFER

12



INICIO DE PROVA

BOA

PROVA

0.00

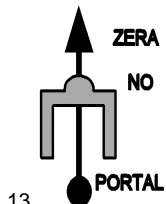

V 18 00.00.00

T1

13

0.03	
V 21 00.00.06	
T2	

14

0.29	
0.00	
V 36 00.00.51	

T3

15

0.03	
V 36	
T3	

16

0.26	
V 36	
T3	

17

BAMBU

0.33	
V 36	
T3	

18

CHIQUEIRO

0.42

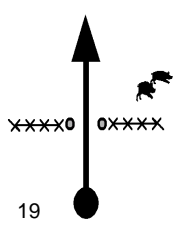

V 36
T3

19

0.56

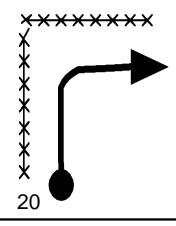

V 36
T3

20

0.69

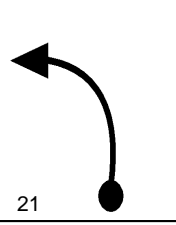

V 36
T3

21

0.77

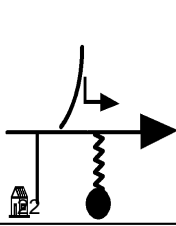

V 42 00.02.08
T4

22

1.11

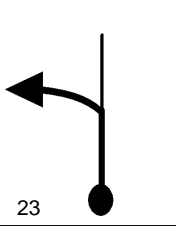

V 42
T4

23

1.15

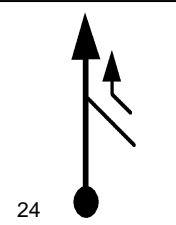

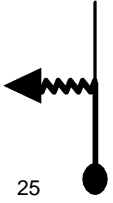

V 42
T4

24

1.20	
V 39 00.02.44	
T5	25

1.25	
V 39	
T5	26

1.31	
V 39	
T5	27

1.33	
V 39	
T5	28

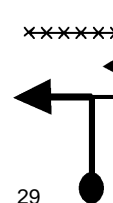
1.47	
V 42 00.03.09	
T6	29

1.59	
V 42	
T6	30

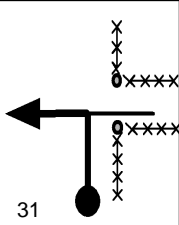
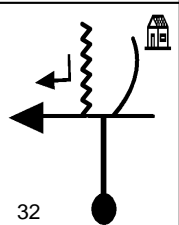
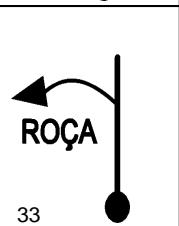
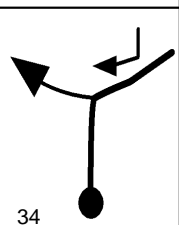
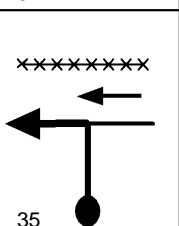
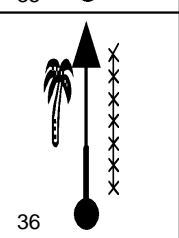
1.72	
V 42	31
T6	
1.94	
V 42	32
T6	
2.21	
V 42	33
T6	
2.29	
V 42	34
T6	
2.43	
V 36 00.04.32	35
T7	
2.55	
V 36	36
T7	

2.69

V 12 00.04.58

T8

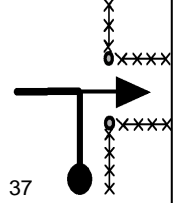

37

2.77

V 12

T8

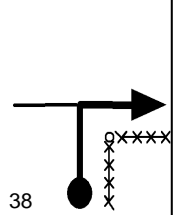

38

2.80

V 36 00.05.31

T9

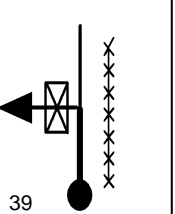

39

2.84

V 36

T9

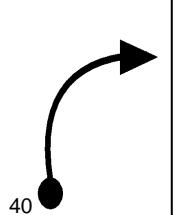

40

2.97

V 36

T9

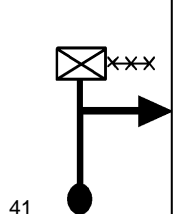

41

BAMP

ARVORE

DEITADA

3.02

V 36

T9

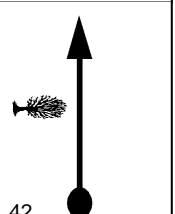

42

3.04	
V 36	
T9	43

3.22	
V 36	
T9	44

COSTEANDO
A CERCA

3.29	
V 36	
T9	45

VISUAL

3.36	
N3'30s00.06.27	
T10	46

VISUAL

3.36	
V 36 00.09.57	
T11	47

3.39

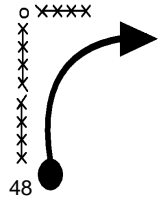

V 12 00.10.00

T12

48

3.41

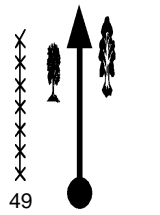

V 18 00.10.06

T13

49

DESCE

CUIDADO

3.42

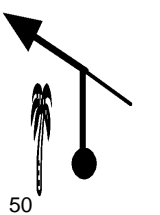

V 18



T13

50

3.45

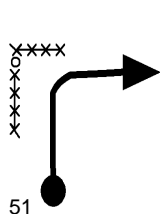

V 18

T13

51

3.47

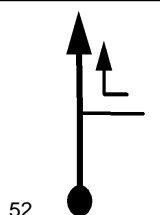

V 27 00.10.18

T14

52

3.50

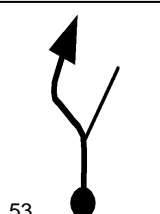

V 27

T14

53

3.51	
V 27	
T14 54	

SIGA
TRILHA
DO BOI

3.53	
V 27	
T14 55	

CONTORNE O
PÉ DE
EUCALIPTO

3.66	
V 36 00.10.43	
T15 56	

3.77	
V 36	
T15 57	

BAMP

3.82	
V 36	
T15 58	

3.85

V 27 00.11.02

T16

59

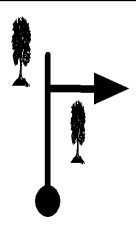

BAMP

3.88

V 27

T16

60



3.91

V 27

T16

61

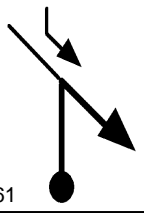

3.96

V 27

T16

62



COSTEAR

MATO

3.97

V 27

T16

63



BAMP

4.11



V 36 00.11.37

T17

64

4.22



V 36

T17

65

BAMP

4.29



V 36

T17

66

4.30

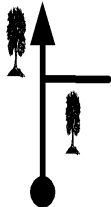

V 36

T17

67

BAMP

4.33

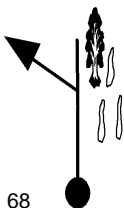

V 36

T17

68

BAMP

4.35

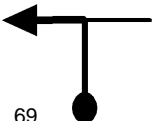

V 36

T17

69

BAMP

4.41



V 36

T17

70

BAMP

4.45



V 36

T17

71

BAMP

4.51



V 36

T17

72

4.53

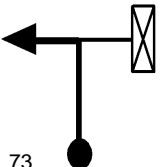

V 36

T17

73

4.62



V 36

T17

74

4.68



V 36

T17

75

CUIDADO

ESTRADA

4.75



N 2' 00.12.41

T18 76

CUIDADO

ESTRADA

4.75

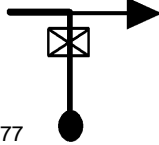

V 36 00.14.41

T19 77

ACELERE

FERVURA

5.08



V 36

T19 78

5.36

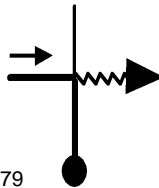

V 27 00.15.42

T20 79

5.45



V 21 00.15.54

T21 80

DESCE

CUIDADO

5.46



81

V 21 00.15.55

 **T22**

5.64

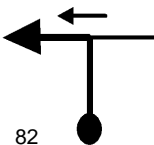

82

V 30 00.16.26

T23

5.81



83

V 30

T23

5.82

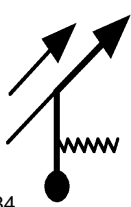

84

V 30

T23

5.86

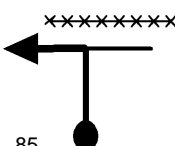

85

V 30

T23

5.97

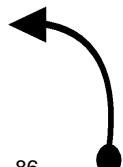

86

V 21 00.17.06

T24

6.23	
V 21	
T24	87
6.40	
V 21	
T24	88
6.43	
V 21	
T24	89
6.59	
V 15 00.18.52	
T25	90
6.92	
V 36 00.20.11	
T26	91
6.96	
V 36	
T26	92

7.13	
V 36	
T26	93

7.14	
V 27 00.20.33	
T27	94

7.18	
V 27	
T27	95

7.24	
V 27	
T27	96

DESCIDA

DO BOI

7.29	
V 15 00.20.53	
T28	97

7.48	
V 15	
T28	98

7.49

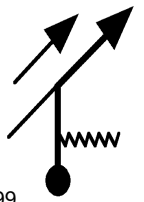

V 27 00.21.41

T29

99

7.53

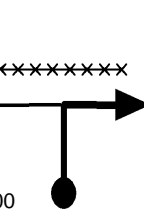

V 36 00.21.47

T30

100

7.68

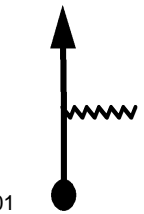

V 36

T30

101

7.70

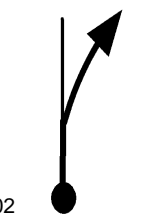

V 36

T30

102

7.76

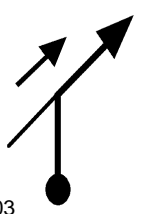

V 36

T30

103

7.98



N 3' 00.22.32

T31

104

7.98
V 36 00.25.32
T32 105

8.10
V 36
T32 106

8.24
V 12 00.25.58
T33 107

8.33
V 12
T33 108

8.40
V 39 00.26.46
T34 109

8.54
0.00
V 39 00.26.58
T35 110

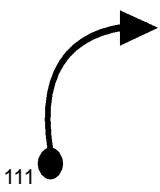
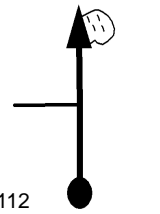
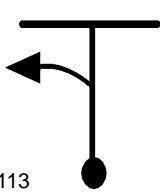
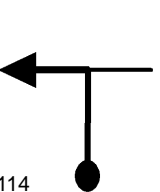
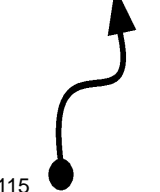
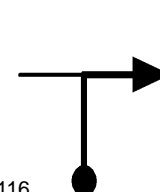
0.07	
V 39	
T35	111
0.24	
V 39	
T35	112
0.52	
V 39	
T35	113
0.62	
V 39	
T35	114
0.85	
V 30 00.28.17	
T36	115
0.93	
V 39 00.28.27	
T37	116

0.95	
V 39	
T37	117

0.98	
V 39	
T37	118

1.02	
V 39 00.28.35	
T38	119



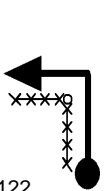

1.09	
V 39	
T38	120

1.13	
V 39	
T38	121

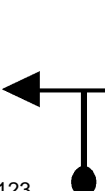
1.17	
V 39	
T38	122

1.36	
V 39 00.29.06	
T39	123

1.49	
V 39	
T39	124

1.76	
V 39	
T39	125

1.79	
V 39 00.29.46	
T40	126

BAMBU	
2.16	
V 39	
T40	127

BAMP

2.19

V 39

T40

128



BAMP

2.30

V 27 00.30.33

T41

129

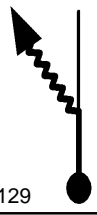

BAMP

2.38

V 27

T41

130

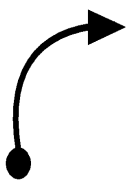

BAMP

2.45

V 27

T41

131





2.48

V 27

T41

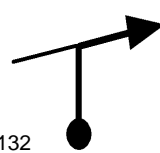
132

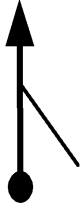

2.57	
N 2' 00.31.09	
T42	133

2.57	
0.00	
V 39 00.33.09	
T43	134

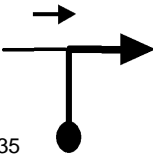



0.30	
V 39	
T43	135

0.68	
V 39	
T43	136

BAMBUSAL

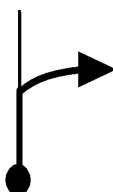
0.70	
V 39	
T43	137

0.83	
V 36 00.34.26	
T44	138

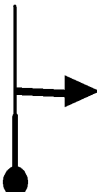
0.94	
V 36	
T44	139
0.96	
V 36 00.34.39	
T45	140
0.98	
V 36	
T45	141
1.21	
V 36	
T45	142
SOBE	
MORRO	
NÃO PULE	
1.42	
V 36	
T45	143
BAMP	
SENTIDO A CERCA	
1.44	
V 36	
T45	144

1.45	xxxo
V 36	
T45 145	

BAMP

1.50	xxxxxx
V 36	
T45 146	

1.53	
V 36 00.35.36	
T46 147	

1.58	→
V 36 00.35.41	
T47 148	

1.80	
V 36	
T47 149	

SOBE

MORRO

NÃO PULE

2.00	
V 36	
T47 150	

SIGA BAMPS

2.02

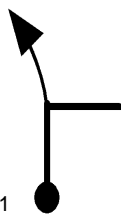

V 36

T47

151

2.06



N 2' 00.36.29

T48

152

2.06



V 36 00.38.29

T49

153

BAMP

2.12



V 36

T49

154

BAMP

2.15



V 36

T49

155

2.16

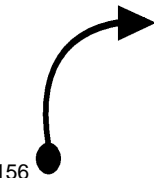

V 36

T49

156

2.19



157

V 36

T49

2.27

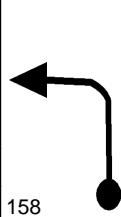

158

V 36

T49

2.34

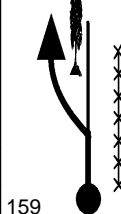

159

V 36

T49

2.36

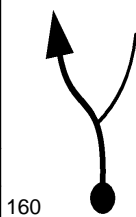

160

V 36

T49

2.39

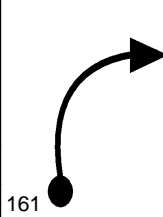

161

V 36

T49

2.48

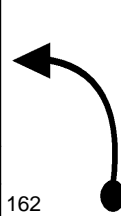



162

V 36

T49

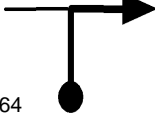
2.53	
N 30s 00.39.16	
T50	163

2.53	
V 36 00.39.46	
T51	164

2.85	
V 36	
T51	165

EROSOES

3.00	
V 36	
T51	166

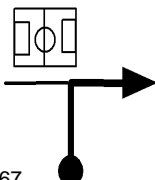
3.28	
V 36	
T51	167

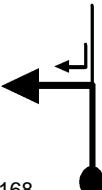
3.34	
V 42 00.41.07	
T52	168

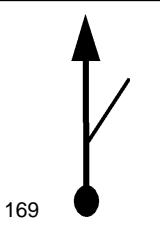
3.46	
V 42	
T52	169

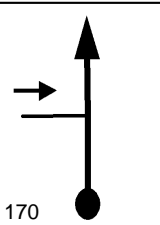
3.54	
V 42	
T52	170

CONTORNE

O MATO

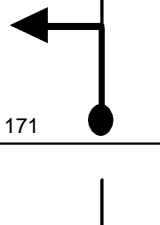
3.61	
V 42	
T52	171

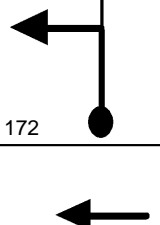
3.72	
V 42	
T52	172

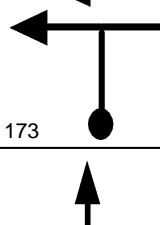
3.76	
V 42	
T52	173

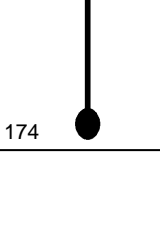
3.80	
V 42	
T52	174

3.92	
V 42	
T52	175

SOBE

COSTEIA ROÇA

4.22	
V 42 00.42.22	
T53	176

4.29	
V 42	
T53	177

BAMP

SIGA PELA

ESQUERDA

NA CANA

4.47	
V 42	
T53	178

4.55	
V 42	
T53	179



4.64

V 42
T53

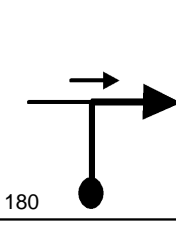

4.94

V 42
T53

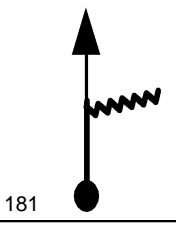

PERIGO

ESTRADA

5.18

N 2' 00.43.44
T54



PERIGO

ESTRADA

5.18

V 39 00.45.44
T55

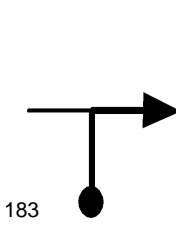

EM DIREÇÃO

A CASA

5.35

V 12 00.46.00

T56

184



5.38

V 12

T56

185

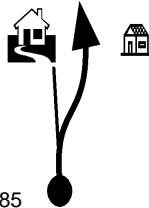

5.40

V 42 00.46.15

T57

186



5.66

V 42

T57

187

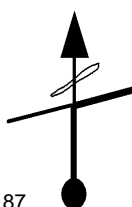

5.93

V 42

T57

188

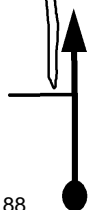

6.12

V 42

T57

189

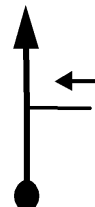

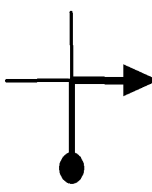
6.21	
0.00	
V 42 00.47.24	
T58	190

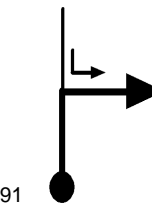
0.14	
V 42	
T58	191

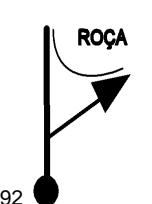
0.26	
V 42	
T58	192

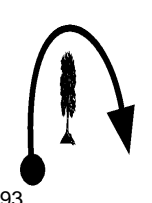
0.37	
V 42	
T58	193

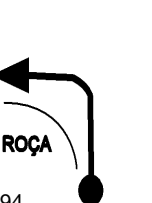
0.49	
V 42	
T58	194

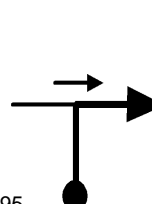
0.56	
V 42	
T58	195

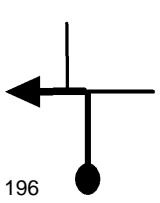
0.66	
V 42	
T58	196

0.74	
N 2' 00.48.28	
T59	197

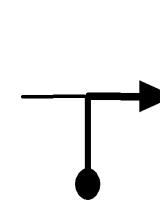
0.74	
0.00	
V 42 00.50.28	
T60	198

0.08	
V 30 00.50.35	
T61	199

DESCE
PALILO
EROSÕES

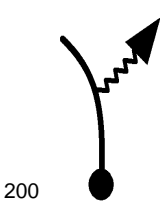
0.14	
V 27 00.50.42	
T62	200

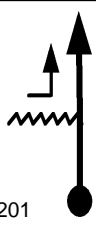
0.22	
V 27	
T62	201

0.23	
V 30 00.50.54	
T63	202

0.40	
V 30	
T63	203

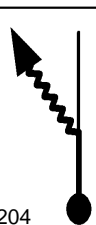
0.46	
V 30	
T63	204

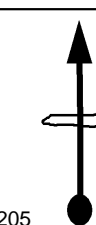
0.50	
V 27 00.51.26	
T64	205

ACELERE

URUBU

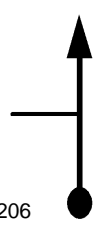
0.55	
V 27	
T64	206

0.70	
V 27	
T64	207
1.05	
V 27	
T64	208
1.89	
V 27	
T64	209
1.99	
V 36 00.54.45	
T65	210
2.02	
V 36	
T65	211
2.07	
V 36	
T65	212

2.11	
V 36	
T65	213
2.17	
V 33 00.55.03	
T66	214
DESCE	
BAMP	
NÃO ERRE	
2.20	
V 21 00.55.06	
T67	215
BAMP	
2.26	
V 21	
T67	216
2.29	
V 21	
T67	217

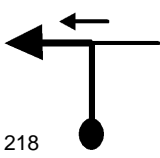
2.35	
V 36 00.55.32	
T68	218

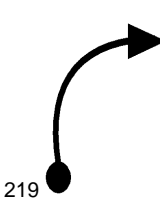
2.36	
V 36	
T68	219

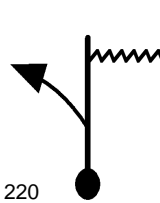
2.53	
V 36	
T68	220

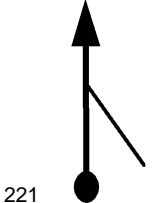
2.67	
V 36	
T68	221

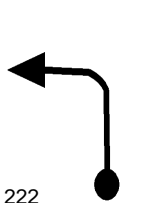
2.76	
V 36	
T68	222

2.85	
V 36	
T68	223

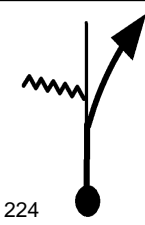
2.89	
V 36	
T68	224

2.92	
N 3' 00.56.29	
T69	225

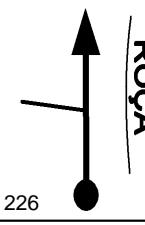
2.92	
V 36 00.59.29	
T70	226

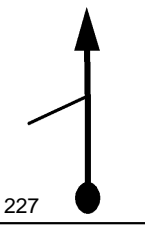
3.08	
V 39 00.59.45	
T71	227

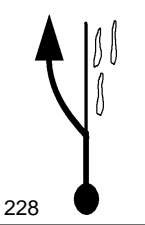
3.30	
V 39	
T71	228

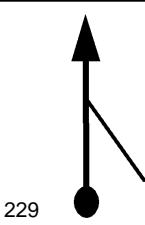
3.45	
V 30 01.00.19	
T72	229

ESTRADA

3.90

V 45 01.01.13

T73

230

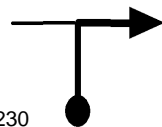

ESTRADA

4.38

V 45

T73

231

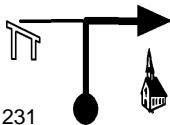

4.77

V 39 01.02.23

T74

232

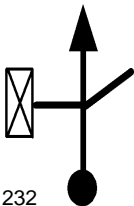

4.80

V 39

T74

233

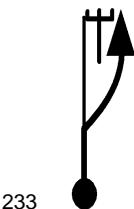

4.82

V 39

T74

234

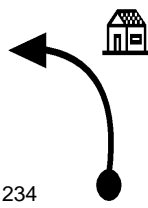

4.88

V 39

T74

235

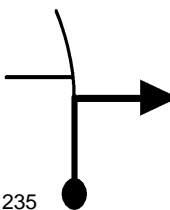

5.04	
V 39	
T74	236

5.34	
V 39	
T74	237

5.35	
V 18 01.03.16	
T75	238

5.45	
V 12 01.03.36	
T76	239



5.49	
V 12	ROÇA
T76	240

5.54

V 21 01.04.03

T77 241

5.61

V 21

T77 242

PELO LADO
DIREITO
DA CANA

5.70

V 30 01.04.31

T78 243

EROSÕES

5.80

V 30

T78 244

BANANEIRA

5.86

V 30

T78 245

5.91	
V 30	
T78 246	

SALÃO VILLA
ALVORADA

6.01	
V 30	
T78 247	

ESTRADA



6.08	
V 42 01.05.16	
T79 248	

6.22	
V 42	
T79 249	

6.82	
V 36 01.06.20	
T80 250	

6.90	
V 36	
T80 251	

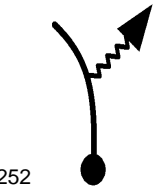
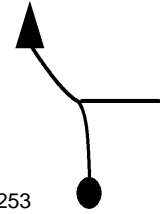
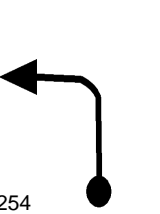
ROÇA

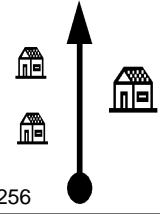
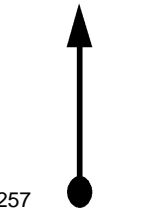
6.98	
V 36	
T80	252
7.00	
V 36	
T80	253
7.02	
V 9 01.06.40	
T81	254
7.08	
N 2' 01.07.04	
T82	255
7.08	
V 9 01.09.04	
T83	256
7.15	
V 40 01.09.32	
T84	257

ESTRADA

7.69

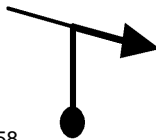

V 42 01.10.20

T85 258

8.36

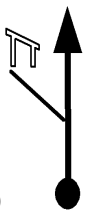

V 42

T85 259

9.49



V 27 01.12.55

T86 260

MOTOS

CONTRA

10.03

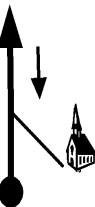

V 27

T86 261

10.12

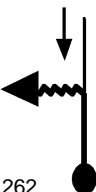

V 39 01.14.19

T87 262

BAMP

10.42

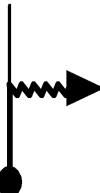

V 39

T87 263

BAMP

10.49



264

V 39

T87

10.63

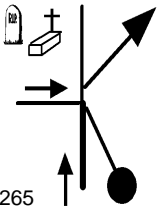

265

V 39

T87

DESCE

10.67



266

V 39

T87

10.83

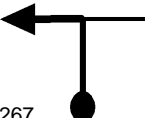

267

V 39

T87

10.86

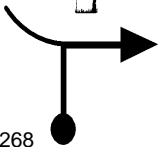

268

V 39

T87

10.90

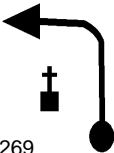

269

V 39

T87

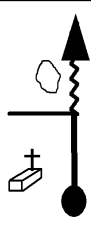
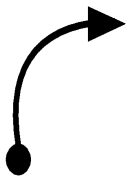
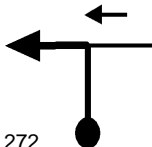
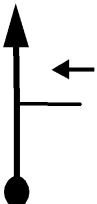
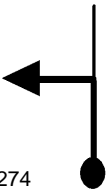
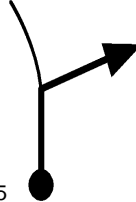
11.00	
0.00	
V 36 01.15.40	
T88	270
0.03	
V 36	
T88	271
0.13	
V 36	
T88	272
0.15	
V 36	
T88	273
0.24	
V 36 01.16.04	
T89	274
0.32	
V 36	
T89	275

0.71	
V 36	
T89 276	

0.80	
V 36	
T89 277	

ATRASOU

TIRE

AQUI

0.90	
V 36	
T89 278	

BAMP

1.34	
V 36	
T89 279	

ESTRADA

1.50	
V 42 01.18.10	
T90 280	

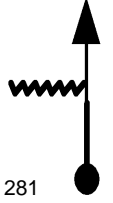
1.59	
V 42	
T90	281

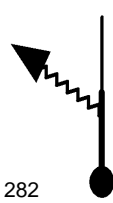
1.68	
V 39 01.18.25	
T91	282

EROSÃO

1.80	
V 39	
T91	283

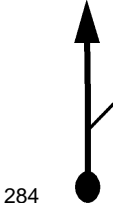
1.89	
V 39	
T91	284

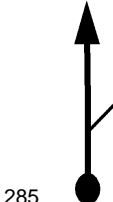
2.03	
V 39	
T91	285

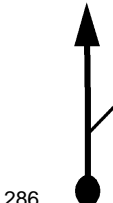
2.13	
V 39	
T91	286

2.17 *****
 V 21 01.19.10
T92 287

2.19
 V 21
T92 288

TOCOS

2.32
 V 42 01.19.36
T93 289

2.76
 V 42
T93 290

BAMP

2.92
 N 2' 01.20.28
T94 291

ESTRADA

2.92
 V 39 01.22.28
T95 292

ESTRADA

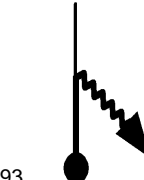
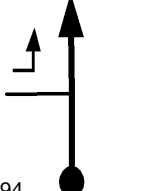
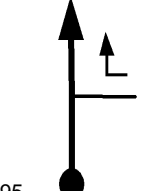
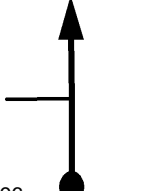
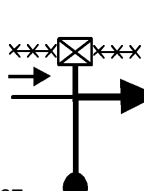
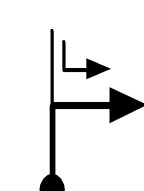
3.03	
V 39	
T95	293
3.18	
V 39	
T95	294
3.21	
V 39	
T95	295
3.30	
V 39	
T95	296
3.65	
V 39	
T95	297
3.74	
V 36 01.23.43	
T96	298

BAMP

4.19

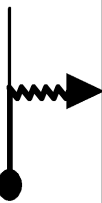

V 36

T96 299



4.29

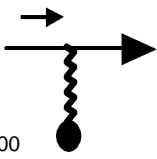

V 36

T96 300

4.38

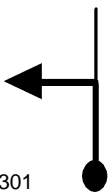

V 36

T96 301

4.46



V 36

T96 302

AQUI O

RENATO JA FOI

COMPRA PÃO

4.61

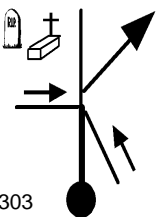

V 42 01.25.10

T97 303

DESCE

4.66

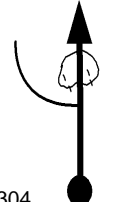

V 42
T97

304

4.81

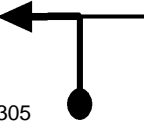

V 42
T97

305

4.86

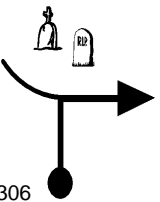

V 42
T97

306

4.90

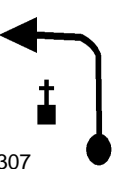

V 42
T97

307

4.99

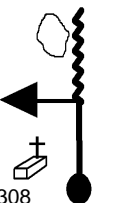

V 42
T97

308

5.05

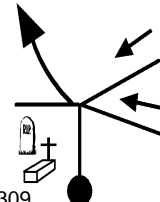

V 42
T97

309

DESCE

5.09

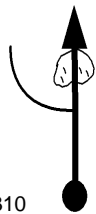

V 42

T97

310

5.25

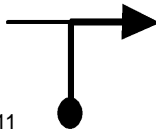

V 42

T97

311

5.29

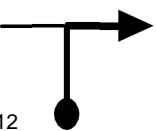

V 42

T97

312

5.37

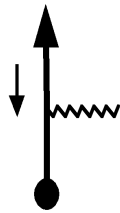

V 42

T97

313

APOIO

DIVISÃO DE ETAPAS

5.45

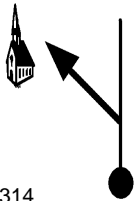

N 19' 01.26.22

T98

314

5.45

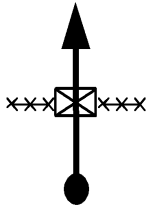

0.00

V 39 01.45.22

T99

315

MOTOS

0.02

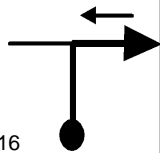

V 39

T99

316

0.16



V 39

T99

317

0.22

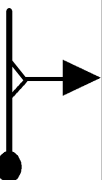

V 45 01.45.43

T100

318

0.61



V 45

T100

319

CARIOCA

0.74

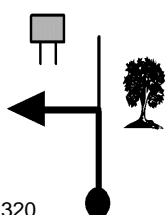

V 45

T100

320

2.27

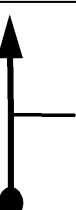

V 45

T100

321

2.36	
V 48 01.48.34	
T101	322

2.63	
V 48	
T101	323

3.23	<p>xxxxxxxx</p>
V 48	
T101	324

3.38	<p>xxxxx</p> <p>xxxxx</p>
V 48	
T101	325

BAMP	
4.05	
V 48	
T101	326

4.15	
V 48	
T101	327

4.76
 V 48
T101 328

5.01
 N 2' 01.51.52
T102 329

5.01
0.00
 V 45 01.53.52
T103 330

ESTRADA

1.24
 V 42 01.55.32
T104 331

2.17
 V 42 01.56.51
T105 332

2.53
 V 42
T105 333

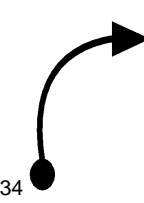
2.58	
V 42	
T105 ³³⁴	

NÃO
ERRE

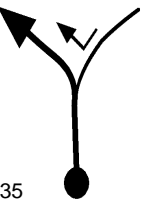
2.84	
V 42	
T105 ³³⁵	

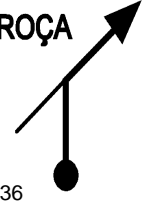
2.97	ROÇA 
V 42	
T105 ³³⁶	

BAMP

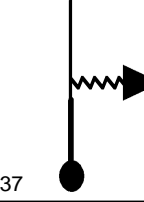
3.31	
V 42	
T105 ³³⁷	

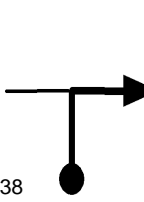
3.40	
V 42	
T105 ³³⁸	

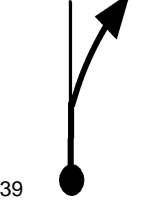
3.74	
V 42	
T105 ³³⁹	

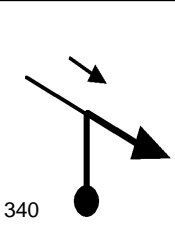
3.85	
V 42	
T105	340

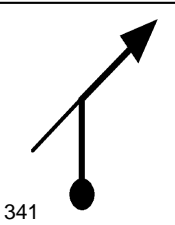
3.98	
V 42	
T105	341

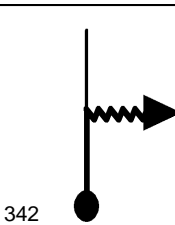
4.31	
V 42	
T105	342

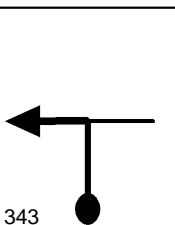
4.40	
V 42	
T105	343

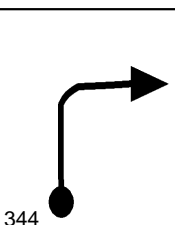
4.60	
V 42	
T105	344

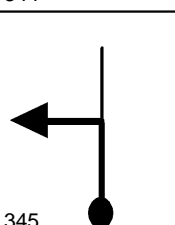
4.75	
V 45 02.00.33	
T106	345

PARREIRA DE

MARACUJÁ

5.32



V 45

T106 346

PARREIRA DE

MARACUJÁ

5.93

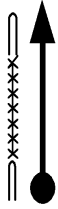

V 45

T106 347

ESTRADA

6.06



N 2' 02.02.17

T107 348

ESTRADA

6.06



V 18 02.04.17

T108 349

6.16

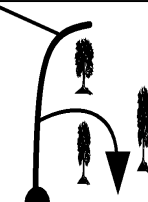

V 12 02.04.37

T109 350

6.22

V 48 02.04.55

T110 351



ATENÇÃO

NÃO

ERRE

7.10

V 48

T110 352

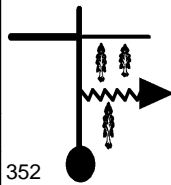

7.12

V 48

T110 353

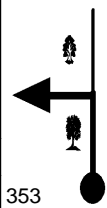

7.13

V 48

T110 354

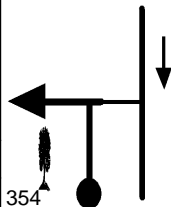

7.15

V 48

T110 355

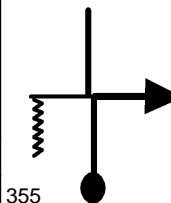

7.56

V 48

T110 356

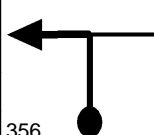

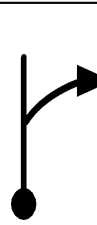

7.59	
V 48	
T110	357

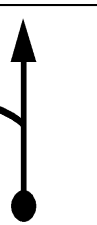
7.71	
V 48	
T110	358

7.78	
V 48	
T110	359



8.20	
V 48	
T110	360

8.99	
V 48	
T110	361

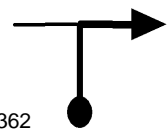
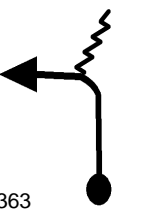
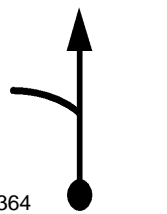
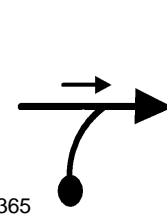
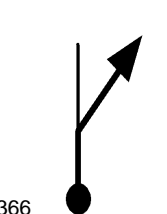
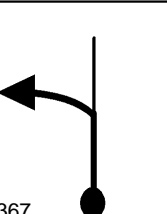
9.08	
V 48	
T110	362
9.72	
V 48	
T110	363
10.05	
V 48	
T110	364
10.37	
V 48	
T110	365
10.49	
V 48	
T110	366
10.56	
V 48	
T110	367

10.67	
V 48	
T110	368

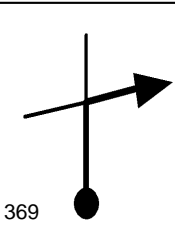
10.77	
V 48	
T110	369

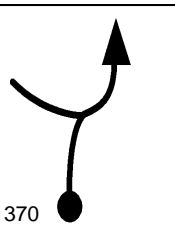
10.91	
V 48	
T110	370

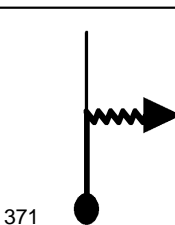
11.29	
V 48	
T110	371

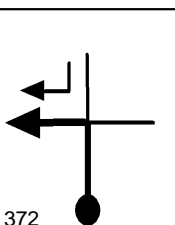
11.68	
V 48	
T110	372

11.74	
V 48	
T110	373

11.81

V 48

T110 374

11.87

V 48

T110 375

11.93

V 48

T110 376

11.99

V 48

T110 377

ESTRADA

12.03

N 2' 02.12.11

T111 378

ESTRADA

12.03

V 48 02.14.11

T112 379

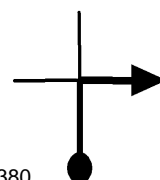
12.41	
V 48	
T112	380

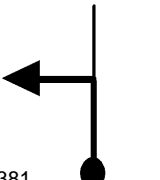
12.55	
V 48	
T112	381

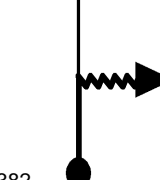
13.43	
V 48	
T112	382

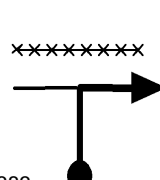
13.60	
V 48	
T112	383

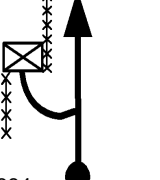
13.69	
V 48	
T112	384

14.43	
V 48	
T112	385

14.49	
V 48	
T112 386	

14.55	
V 48	
T112 387	

14.60	
V 48	
T112 388	

14.63	
V 48	
T112 389	

14.68	
V 48	
T112 390	

14.81	
V 48	
T112 391	

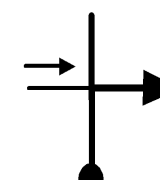
14.87	
V 48	
T112	392

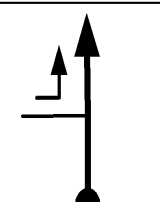
14.92	
V 48	
T112	393

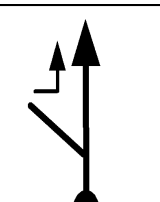
14.97	
V 48	
T112	394

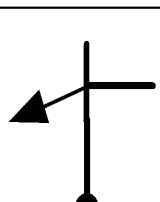
15.00	
V 48	
T112	395

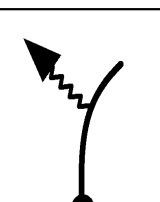
15.02	
V 48	
T112	396

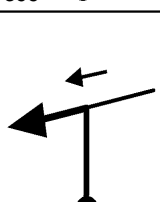
15.04	
V 48	
T112	397

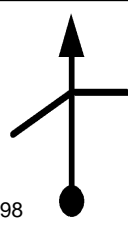
15.07	
V 48	
T112	398

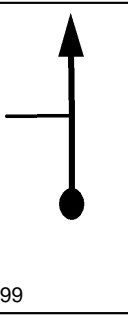
15.18	
0.00	
V 51 02.18.07	
T113	399

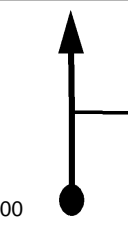
0.04	
V 51	
T113	400

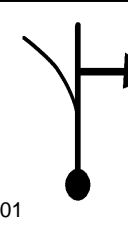
0.15	
V 51	
T113	401

0.45	
V 51	
T113	402

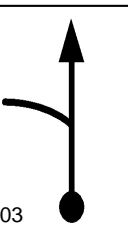
0.49	
V 51	
T113	403

0.53	
V 51	
T113	404

0.59	ROÇA
V 51	
T113	405

0.87	
V 51	
T113	406

0.99	
V 51	
T113	407

1.32	
V 51	
T113	408

1.77	
V 51	
T113	409

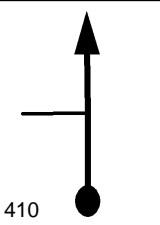
2.10	
V 51	
T113 ₄₁₀	

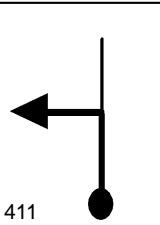
2.16	
V 51	
T113 ₄₁₁	

COSTEANDO
MATO
BAMP

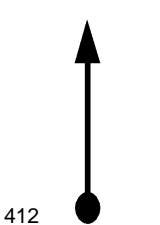
2.74	
V 51	
T113 ₄₁₂	

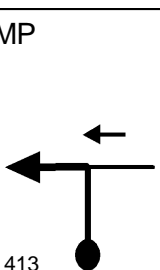
3.11	
V 51	
T113 ₄₁₃	

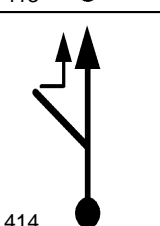
3.15	
V 51	
T113 ₄₁₄	

3.18

V 51

T113 415

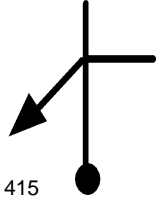

3.20

V 51

T113 416

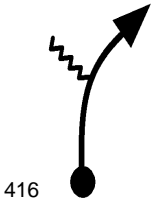

4.11

N 2' 02.22.57

T114 417



4.11

V 51 02.24.57

T115 418

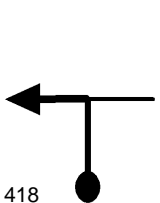

4.17

V 51

T115 419

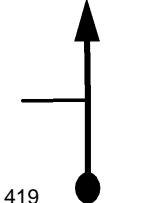



4.65

V 51

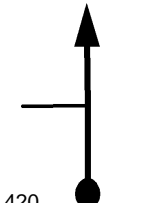
T115 420

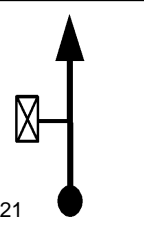

5.21	
V 51	
T115	421

5.58	
V 15 02.26.41	
T116	422

5.61	
V 15	
T116	423

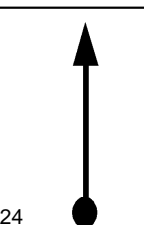
5.70	
V 48 02.27.10	
T117	424

6.54	
V 48	
T117	425

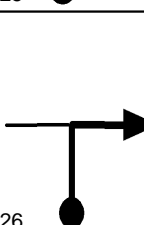
6.58	
V 48	
T117	426

ESTRADA

7.42



Nº'30s 02.29.19

T118 427

ESTRADA

7.42

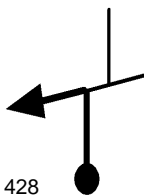

V 48 02.31.49

T119 428

9.01

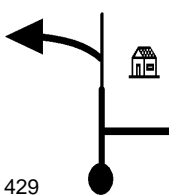

V 45 02.33.48

T120 429

9.27

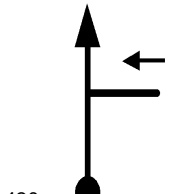

V 45

T120 430

9.89

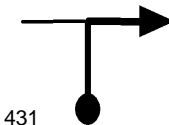

V 45

T120 431

10.03

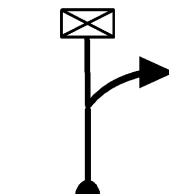

V 45

T120 432

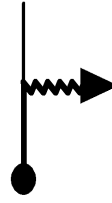
10.70	
V 45	
T120 433	

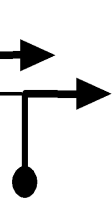
10.82	
V 45	
T120 434	

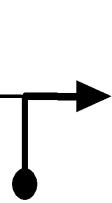
11.41	
V 45	
T120 435	

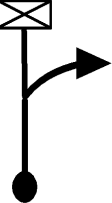
11.55	
V 45	
T120 436	

12.23	
V 45	
T120 437	

ESTRADA	
12.47	
N 1' 02.38.25	
T121 438	

ESTRADA

12.47

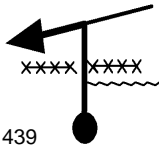

V 48 02.39.25

T122

439

13.97

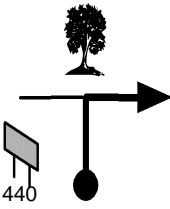

V 48

T122

440

14.06

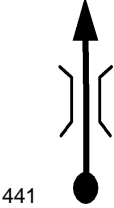

V 48

T122

441

14.45

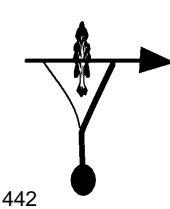

V 48

T122

442

14.58

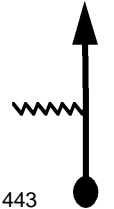

V 48

T122

443

14.70

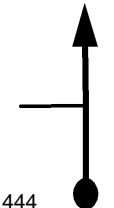

V 48

T122

444

ATENÇÃO

14.89



V 39 02.42.27

T123 445

15.01



V 39

T123 446

15.25



V 39

T123 447

15.35



V 39

T123 448

15.39

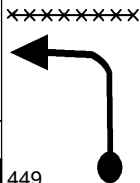

V 30 02.43.13

T124 449

TOCO

15.51

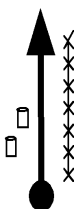

V 30



T124 450

15.54	
V 42 02.43.31	
T125	451

15.64	
V 40 02.43.39	
T126	452

15.69	ROÇA
V 42 02.43.44	
T127	453

16.09	
V 42	
T127	454

16.19	
V 42	
T127	455

16.50	
V 39 02.44.53	
T128	456

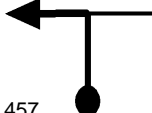
16.60	ROÇA 
V 39	
T128 457	

16.97	
V 39	
T128 458	

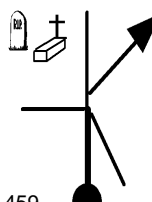
17.10	
V 39	
T128 459	

DESCE

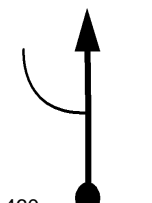
17.14	
V 39	
T128 460	

17.30	
N 2' 02.46.07	
T129 461	

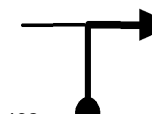
17.30	
V 48 02.48.07	
T130 462	

ESTRADA

17.35

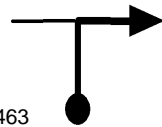

V 48

 **T130** 463

17.49

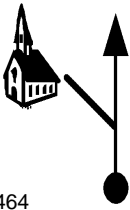

V 30 02.48.21

T131 464

18.02



V 48 02.49.25

T132 465

19.00

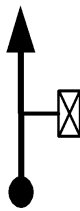

0.00

V 48 02.50.38

T133 466

2.23

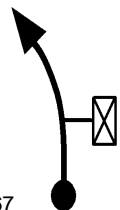

V 48

T133 467

ACELERE

ESCOLINHA DE

PACOTES

DO ADEMAR

2.41

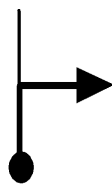

V 36 02.53.39

T134 468

2.61

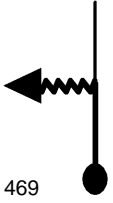

V 36

T134 469

ESTRADA

2.88

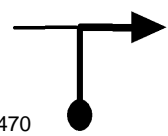

V 36

☠☠☠ T134 470

FERVURA

3.32

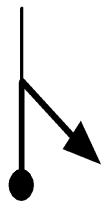

V 38 02.55.10

T135 471

3.76

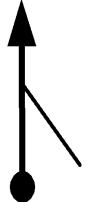

V 38

T135 472

3.79

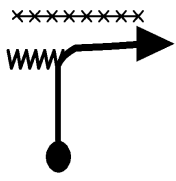

V 38

T135 473

3.93

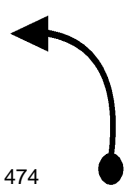

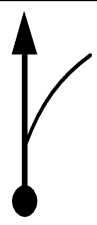

V 38

T135 474

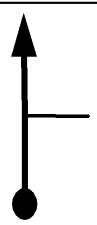
3.96	
V 38	
T135	475

4.03	
V 38	
T135	476

4.07	
V 38	
T135	477

4.16	
V 38	
T135	478

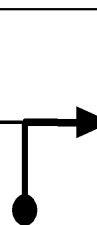
4.30	
V 38	
T135	479

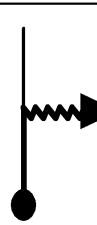

4.48	
V 36 02.57.00	
T136	480

4.53	
V 36	
T136	481

4.62	
V 36	
T136	482

4.75	
V 36	
T136	483

5.01	
V 30 02.57.53	
T137	484

5.22	
0.00	
V 21 02.58.18	
T138	485

0.08	
V 21	
T138	486

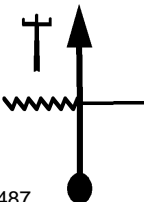
0.16	
V 21	
T138	487

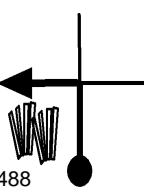
0.42	
V 21	
T138	488

AGRADECEMOS

SUA

PRESENÇA

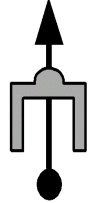
0.45	
V 21 02.59.35	
T138	489

FIM DE PROVA !!



www.t15.com.br

AGRADECIMENTOS AOS PILOTOS PARTICIPANTES.
E A TODOS OS COLABORADORES,
AMIGOS E PCZEIROS LIGADOS A ESTE EVENTO!!!!
OBIGADO A TODOS...

Tempo de Prova

MÉDIA A 02:59:35

FIM
