

# INICIO

## GRADUADOS

COPA MTC  
25/05/2019



## IMPORTANTE

Média "A" para Graduados

Média "B" para Over 40,  
Júnior

Média "C" para Over 45,  
Duplas, Estreantes e  
Equipes

**CUIDADO AO ATRAVESSAR AS  
ESTRADAS!!!**

**CUIDADO COM AS  
CRIANÇAS!!!**

**CUIDE DA SUA VIDA E DA  
DO SEU COLEGA DE  
ESPORTE!!!!**



**CUIDADO**



**ATENÇÃO**



**MUITA ATENÇÃO**



# Tempo de Prova



GRADUADOS 02:53:24







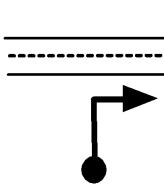
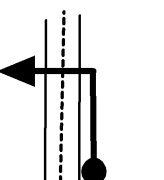

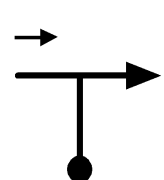
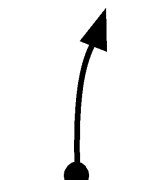
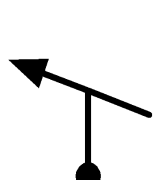
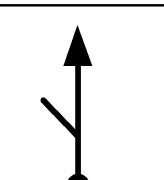
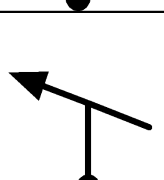
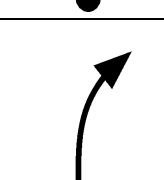
## AFERIÇÃO

	0.00
	1 AFER
	0.71
	2 AFER
	1.17
	3 AFER
	1.60
	4 AFER
	1.67
	5 AFER
	1.75
	6 AFER

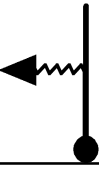

	1.83	
	7	AFER
	2.00	
	0.00	
	8	AFER
		
<b>INICIO DE PROVA</b>		
	0.00	
	V 36	00.00.00
	9	T1
	0.08	
	V 36	00.00.08
	10	T1
	0.62	
	V 36	00.01.02
	11	T1
	0.66	
	V 36	00.01.06
	12	T1

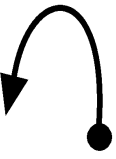
	0.74
	D 3' 00.01.14
	13 T2
	0.93
	V 36 00.04.14
	14 T3
	
	0.98
	V 45 00.04.19
	15 T4
	1.21
	V 45 00.04.37
	16 T4
	1.23
	V 45 00.04.39
	17 T4
	1.29
	V 45 00.04.44
	18 T4
	1.43
	V 45 00.04.55
	19 T4
	1.49
	V 45 00.05.00
	20 T4

	1.51
	V 30 00.05.01
	21 <b>T5</b>
	1.91
	V 30 00.05.49
	22 <b>T5</b>
	1.99
	V 45 00.05.59
	23 <b>T6</b>
PELA ESQUERDA	
BAMP	
	2.14
	V 45 00.06.11
	24 <b>T6</b>
	2.36
	V 45 00.06.29
	25 <b>T6</b>
	2.43
	V 51 00.06.34
	26 <b>T7</b>
	2.82
	V 51 00.07.02
	27 <b>T7</b>
	2.87
	V 51 00.07.05
	28 <b>T7</b>



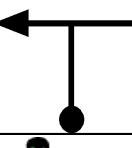
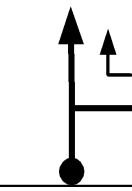
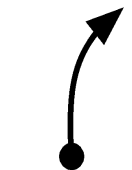
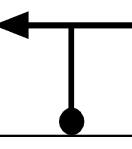
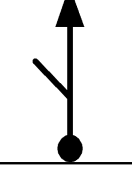
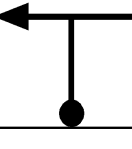

	<b>3.25</b>	
	V 51	00.07.32
	29	<b>T7</b>
	<b>3.28</b>	
	V 36	00.07.34
	30	<b>T8</b>
	<b>3.39</b>	
	V 42	00.07.45
	31	<b>T9</b>
<b>CUIDADO</b>		
VALO		
		
	<b>3.47</b>	
	V 42	00.07.52
	32	<b>T9</b>
<b>BAMP</b>		
	<b>3.70</b>	
	V 42	00.08.12
	33	<b>T9</b>
<b>SUBA</b>		
<b>BAMP</b>		
	<b>3.75</b>	
	V 33	00.08.16
	34	<b>T10</b>
	<b>3.80</b>	
	V 33	00.08.22
	35	<b>T10</b>

BAMP

	3.92	
	V 33	00.08.35
	36	<b>T10</b>
	4.03	
	V 33	00.08.47
	37	<b>T10</b>
	4.24	
	V 45	00.09.10
	38	<b>T11</b>
	4.46	
	V 45	00.09.27
	39	<b>T11</b>
	4.50	
	V 45	00.09.30
	40	<b>T11</b>
	4.56	
	V 45	00.09.35
	41	<b>T11</b>
	4.69	
	V 45	00.09.46
	42	<b>T11</b>
	4.74	
	V 45	00.09.50
	43	<b>T11</b>

	<b>4.78</b>	
	V 30	00.09.53
	44	<b>T12</b>
	<b>5.26</b>	
	V 45	00.10.50
	45	<b>T13</b>
COSTER		
O MATO		
	<b>5.40</b>	
	V 45	00.11.02
	46	<b>T13</b>
	<b>5.49</b>	
	V 45	00.11.09
	47	<b>T13</b>
	<b>5.54</b>	
	V 51	00.11.13
	48	<b>T14</b>
	<b>5.72</b>	
	V 51	00.11.25
	49	<b>T14</b>
	<b>6.11</b>	
	V 51	00.11.53
	50	<b>T14</b>
	<b>6.16</b>	
	V 51	00.11.56
	51	<b>T14</b>

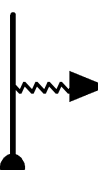
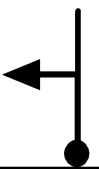

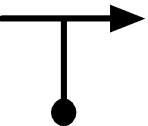
	<b>6.54</b>	
	V 27	00.12.23
	52	<b>T15</b>
COSTEAR O BARRANCO		
	<b>6.59</b>	
	V 27	00.12.30
	53	<b>T15</b>
	<b>6.75</b>	
	V 27	00.12.51
	54	<b>T15</b>
BAMP		
	<b>6.87</b>	
	V 27	00.13.07
	55	<b>T15</b>
	<b>6.91</b>	
	V 27	00.13.13
	56	<b>T15</b>
NO MATO		
	<b>7.06</b>	
	V 27	00.13.33
	57	<b>T15</b>
	<b>7.25</b>	
	N 1'	00.13.58
	58	<b>T16</b>
	<b>7.25</b>	
	V 51	00.14.58
	59	<b>T17</b>



7.50

V 51 00.15.16

60 T17



7.55

V 51 00.15.19

61 T17

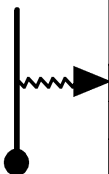

7.77

V 27 00.15.35

62 T18

VALO



7.96

V 27 00.16.00

63 T18

SUBA

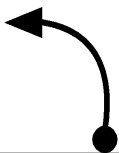

7.99

V 27 00.16.04

64 T18



8.00

V 27 00.16.05

65 T18

CUIDADO

AÇUDE

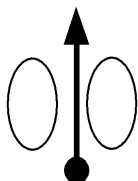

8.15

V 27 00.16.25

66 T18

	8.22	
	V 27	00.16.35
	67	<b>T18</b>



	8.29	
	V 48	00.16.44
	68	<b>T19</b>



	8.57	
	V 48	00.17.05
	69	<b>T19</b>

LAGO

	8.93	
	V 57	00.17.32
	70	<b>T20</b>



	9.32	
	V 57	00.17.57
	71	<b>T20</b>

	9.72	
	V 57	00.18.22
	72	<b>T20</b>

	9.80	
	V 36	00.18.27
	73	<b>T21</b>

	9.92	
	N 1'	00.18.39
	74	<b>T22</b>

	9.92	
	V 48	00.19.39
	75	<b>T23</b>

LAGO

	10.28	
	V 57	00.20.06
	76	<b>T24</b>







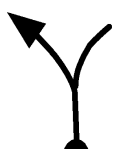
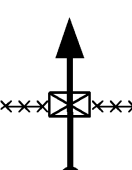

	10.68	
	V 57	00.20.31
	77	<b>T24</b>

	10.95	
	V 57	00.20.48
	78	<b>T24</b>

	11.20	
	V 24	00.21.04
	79	<b>T25</b>

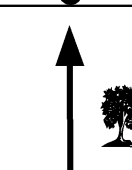
	11.52	
	N 1'	00.21.52
	80	<b>T26</b>



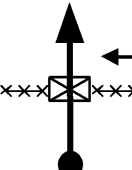



	11.52	
	<b>0.00</b>	
	V 57	00.22.52
	81	<b>T27</b>

	<b>0.39</b>	
	V 57	00.23.17
	82	<b>T27</b>
	<b>0.48</b>	
	V 57	00.23.22
	83	<b>T27</b>
AÇUDE		
SIGA O BAMP		
		
	<b>0.81</b>	
	V 24	00.23.43
	84	<b>T28</b>
	<b>0.90</b>	
	V 24	00.23.57
	85	<b>T28</b>
	<b>0.96</b>	
	V 24	00.24.06
	86	<b>T28</b>
		
	<b>1.10</b>	
	V 48	00.24.27
	87	<b>T29</b>
		
	<b>1.37</b>	
	V 48	00.24.47
	88	<b>T29</b>





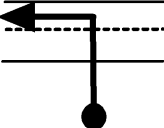
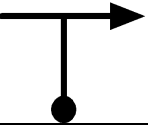
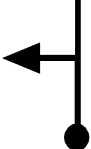

	1.73	
	V 57	00.25.14
	89	<b>T30</b>
	2.12	
	V 57	00.25.39
	90	<b>T30</b>
	2.38	
	V 57	00.25.55
	91	<b>T30</b>
	2.62	
	V 57	00.26.10
	92	<b>T30</b>
	2.90	
	V 57	00.26.28
	93	<b>T30</b>
	3.43	
	V 57	00.27.01
	94	<b>T30</b>
	3.54	
	N 2'	00.27.08
	95	<b>T31</b>
	3.54	
	V 15	00.29.08
	96	<b>T32</b>

	3.60
	V 15 00.29.23
	97 T32
PELO RIO	
	3.68
	V 15 00.29.42
	98 T32
	3.74
	D 5' 00.29.56
	99 T33
	5.18
	100 T33
	5.53
	V 42 00.34.56
	101 T34
	6.02
	V 42 00.35.38
	102 T34
	7.46
	V 42 00.37.42
	103 T34
	7.78
	V 42 00.38.09
	104 T34

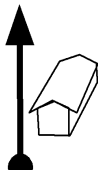
MATA BURRO

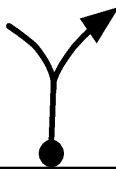
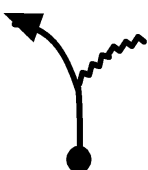
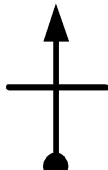

	8.56
	V 18 00.39.16
	105 <b>T35</b>
	8.74
	V 18 00.39.52
	106 <b>T35</b>
	8.79
	N 1' 00.40.02
	107 <b>T36</b>
	
	8.79
	0.00
	V 39 00.41.02
108 <b>T37</b>	
	0.41
	V 39 00.41.40
	109 <b>T37</b>
	1.16
	V 18 00.42.49
	110 <b>T38</b>
	1.29
	V 18 00.43.15
	111 <b>T38</b>







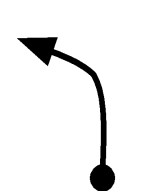
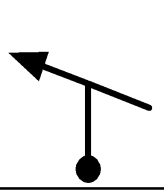
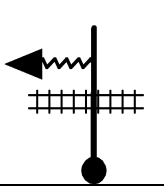
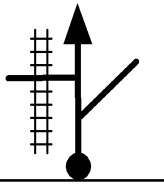
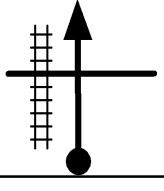
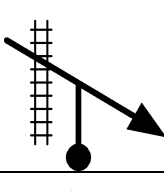
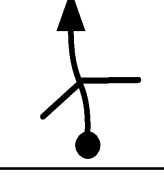

PAIOL	
	1.36
	V 42 00.43.29
	112 <b>T39</b>
	1.84
	N 1' 00.44.10
	113 <b>T40</b>
POR DENTRO	
	1.84
	V 39 00.45.10
	114 <b>T41</b>
	1.89
	V 39 00.45.15
	115 <b>T41</b>
	1.96
	V 39 00.45.21
	116 <b>T41</b>
	2.15
	V 39 00.45.39
	117 <b>T41</b>
	2.39
	V 39 00.46.01
	118 <b>T41</b>
	2.48
	V 27 00.46.09
	119 <b>T42</b>

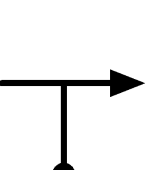

	2.53
	V 27 00.46.16
	120 T42
	2.76
	V 27 00.46.47
	121 T42
	2.84
	V 27 00.46.57
	122 T42
	2.86
	V 36 00.47.00
	123 T43
	2.98
	V 36 00.47.12
	124 T43
	3.08
	V 36 00.47.22
	125 T43
	3.58
	V 36 00.48.12
	126 T43

	<b>3.64</b>	
	V 36	00.48.18
	127	<b>T43</b>
	<b>3.88</b>	
	V 36	00.48.42
	128	<b>T43</b>
	<b>3.95</b>	
	V 21	00.48.49
	129	<b>T44</b>
	<b>4.58</b>	
	V 21	00.50.37
	130	<b>T44</b>
	<b>4.75</b>	
	V 21	00.51.06
	131	<b>T44</b>
	<b>5.59</b>	
	V 33	00.53.30
	132	<b>T45</b>
	<b>6.49</b>	
	V 39	00.55.08
	133	<b>T46</b>
	<b>7.08</b>	
	N 3'	00.56.03
	134	<b>T47</b>

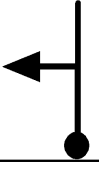
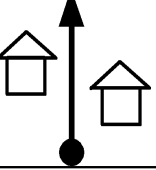
☠☠	
	7.08
	V 39 00.59.03
	135 <b>T48</b>
FINAL DO ASFALTO	
	7.92
	V 39 01.00.20
	136 <b>T48</b>
PELA DIREITA	
	8.05
	V 24 01.00.32
	137 <b>T49</b>
PELA ESQUERDA	
☠	
	8.36
	V 24 01.01.19
	138 <b>T49</b>
	8.74
	V 21 01.02.16
	139 <b>T50</b>
☠☠☠	
	9.33
	V 21 01.03.57
	140 <b>T50</b>
	9.40
	V 21 01.04.09
	141 <b>T50</b>

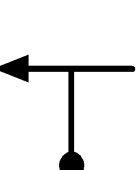
	9.50	V 21	01.04.26
	142	<b>T50</b>	
	9.54	V 18	01.04.33
	143	<b>T51</b>	
	9.93		
	0.00	V 39	01.05.51
	144	<b>T52</b>	
	0.35	V 39	01.06.23
	145	<b>T52</b>	
	0.46	V 18	01.06.33
	146	<b>T53</b>	
	0.50	V 45	01.06.41
	147	<b>T54</b>	
	0.74	V 45	01.07.00
	148	<b>T54</b>	
	2.07	V 45	01.08.47
	149	<b>T54</b>	



	2.35	
	V 12	01.09.09
	150	<b>T55</b>
	2.67	
	N 2'	01.10.45
	151	<b>T56</b>
	2.67	
	V 21	01.12.45
	152	<b>T57</b>
	2.83	
	V 33	01.13.13
	153	<b>T58</b>
	3.25	
	V 30	01.13.59
	154	<b>T59</b>
	3.44	
	V 30	01.14.21
	155	<b>T59</b>
	3.46	
	V 30	01.14.24
	156	<b>T59</b>
	3.53	
	V 30	01.14.32
	157	<b>T59</b>

☠☠	
	3.72
	V 30   01.14.55
	158   <b>T59</b>
	4.05
	V 30   01.15.35
	159   <b>T59</b>
☠☠	
	4.26
	V 30   01.16.00
	160   <b>T59</b>
☠☠	
	4.32
	V 30   01.16.07
	161   <b>T59</b>
	4.65
	V 30   01.16.47
	162   <b>T59</b>
	4.80
	V 30   01.17.05
	163   <b>T59</b>
	5.02
	V 30   01.17.31
	164   <b>T59</b>
	5.12
	V 30   01.17.43
	165   <b>T59</b>



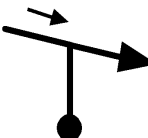
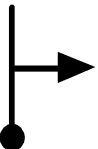
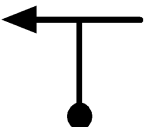

	
	<b>5.63</b>
	V 30 01.18.44
	166 <b>T59</b>
	
	<b>5.70</b>
	V 30 01.18.53
	167 <b>T59</b>
	<b>6.02</b>
	V 30 01.19.31
	168 <b>T59</b>
	<b>6.17</b>
	V 30 01.19.49
	169 <b>T59</b>
PELA ESQUERDA	
ATOLEIRO	
	
	<b>6.23</b>
	V 30 01.19.56
	170 <b>T59</b>
DESCE	
	<b>6.33</b>
	V 30 01.20.08
	171 <b>T59</b>
	<b>6.44</b>
	N 1' 01.20.21
	172 <b>T60</b>

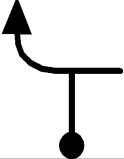
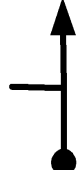
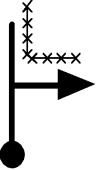

	6.44
	V 45 01.21.21
	173 <b>T61</b>
	6.93
	V 45 01.22.01
	174 <b>T61</b>
	7.30
	V 45 01.22.30
	175 <b>T61</b>
	7.69
	V 45 01.23.01
	176 <b>T61</b>
	7.96
	V 39 01.23.23
	177 <b>T62</b>
<b>CUIDADO</b>	
	8.51
	V 39 01.24.14
	178 <b>T62</b>
	8.55
	V 39 01.24.17
	179 <b>T62</b>
	8.59
	V 39 01.24.21
	180 <b>T62</b>

	
	<b>8.65</b>
	V 39   01.24.27
	181   <b>T62</b>
	<b>8.69</b>
	V 39   01.24.30
	182   <b>T62</b>
	<b>8.72</b>
	V 39   01.24.33
	183   <b>T62</b>
	<b>8.78</b>
	V 39   01.24.39
	184   <b>T62</b>
	<b>9.24</b>
	N 1'   01.25.21
	185   <b>T63</b>
	<b>9.24</b>
	V 39   01.26.21
	186   <b>T64</b>
	<b>9.52</b>
	V 39   01.26.47
	187   <b>T64</b>
	<b>9.95</b>
	V 45   01.27.27
	188   <b>T65</b>

BAMP

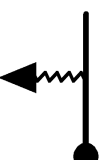



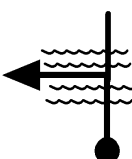
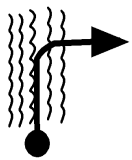



	10.34	
	V 27	01.27.58
	189	<b>T66</b>
	10.41	
	V 27	01.28.07
	190	<b>T66</b>
	10.43	
	V 27	01.28.10
	191	<b>T66</b>
	10.47	
	V 27	01.28.15
	192	<b>T66</b>
	10.53	
	V 27	01.28.23
	193	<b>T66</b>
	10.56	
	V 9	01.28.27
	194	<b>T67</b>

PELO RIO

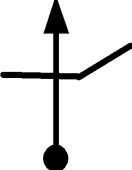





	10.58	
	V 9	01.28.35
	195	<b>T67</b>
	10.60	
	V 9	01.28.43
	196	<b>T67</b>

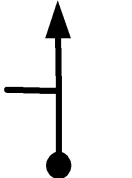

	10.62	
	V 9	01.28.51
	197	<b>T67</b>
SEGUIR A PISTA		
	10.63	
	V 48	01.28.55
	198	<b>T68</b>
	10.91	
	V 48	01.29.16
	199	<b>T68</b>
	11.84	
	V 48	01.30.26
	200	<b>T68</b>
	12.12	
	V 48	01.30.47
	201	<b>T68</b>
FINAL		
PRIMEIRA		
PARTE		
	12.17	
	N 20'	01.30.51
	202	<b>T69</b>
	12.17	
	<b>0.00</b>	
	V 42	01.50.51
203	<b>T70</b>	

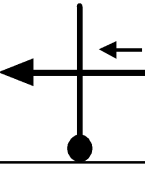
FINAL DO ASFALTO

	1.64
	V 42 01.53.11
	204 T70
	1.71
	V 42 01.53.17
	205 T70
	1.79
	V 42 01.53.24
	206 T70
	1.87
	V 42 01.53.31
	207 T70
	2.04
	V 42 01.53.45
	208 T70
	2.31
	V 42 01.54.09
	209 T70
	2.63
	V 15 01.54.36
	210 T71
	2.80
	V 42 01.55.17
	211 T72

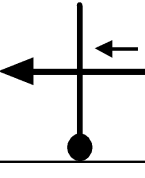
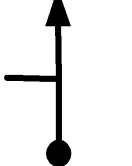
	2.85
	V 42 01.55.21
	212 T72
	3.21
	V 42 01.55.52
	213 T72
	3.44
	V 24 01.56.12
	214 T73
X(6)	
	3.62
	V 39 01.56.39
	215 T74
	3.91
	V 39 01.57.05
	216 T74
X(6)	
	3.96
	V 39 01.57.10
	217 T74
	4.09
	V 39 01.57.22
	218 T74
	4.20
	V 33 01.57.32
	219 T75

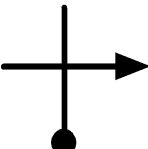

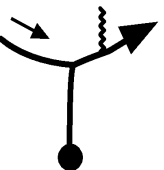
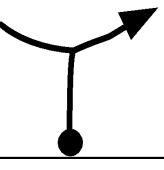
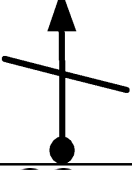
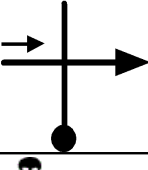
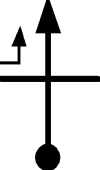
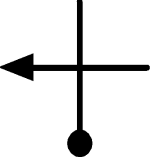



	4.30	
	V 33	01.57.43
	220	<b>T75</b>
	4.38	
	V 33	01.57.52
	221	<b>T75</b>
		
	4.45	
	V 30	01.57.59
	222	<b>T76</b>
	4.49	
	V 30	01.58.04
	223	<b>T76</b>
	4.75	
	V 30	01.58.35
	224	<b>T76</b>
	4.83	
	N 1'	01.58.45
	225	<b>T77</b>
		
	4.83	
	V 39	01.59.45
	226	<b>T78</b>
	5.08	
	V 39	02.00.08
	227	<b>T78</b>





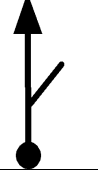

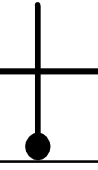
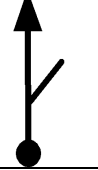
	<b>5.17</b>	
	V 39	02.00.16
	228	<b>T78</b>
	<b>5.42</b>	
	V 39	02.00.40
	229	<b>T78</b>
☠☠		
	<b>5.64</b>	
	V 39	02.01.00
	230	<b>T78</b>
	<b>5.75</b>	
	V 39	02.01.10
	231	<b>T78</b>
	<b>5.87</b>	
	V 39	02.01.21
	232	<b>T78</b>
☠☠		
	<b>6.00</b>	
	V 39	02.01.33
	233	<b>T78</b>
☠		
	<b>6.07</b>	
	V 39	02.01.40
	234	<b>T78</b>
	<b>6.42</b>	
	V 39	02.02.12
	235	<b>T78</b>

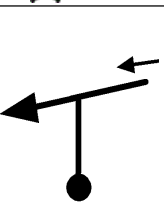

	6.55	
	V 39	02.02.24
	236	<b>T78</b>
X(6)		
	6.64	
	V 39	02.02.32
	237	<b>T78</b>
	6.67	
	V 33	02.02.35
	238	<b>T79</b>
☠☠		
	7.44	
	V 39	02.03.59
	239	<b>T80</b>
	7.73	
	V 30	02.04.26
	240	<b>T81</b>
	8.27	
	V 30	02.05.30
	241	<b>T81</b>
X(6)		
	8.29	
	V 30	02.05.33
	242	<b>T81</b>

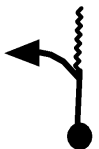

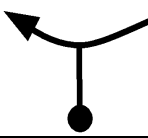
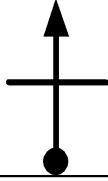

	8.32	V 36	02.05.36
	243	<b>T82</b>	
	8.39	N 1'	02.05.43
	244	<b>T83</b>	
	8.39	V 36	02.06.43
	245	<b>T84</b>	
	8.54	V 36	02.06.58
	246	<b>T84</b>	
	8.88	V 39	02.07.32
	247	<b>T85</b>	
	9.36	V 39	02.08.17
	248	<b>T85</b>	
	9.46	V 39	02.08.26
	249	<b>T85</b>	
	9.85	V 39	02.09.02
	250	<b>T85</b>	





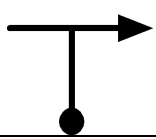

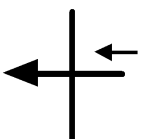
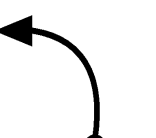
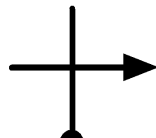
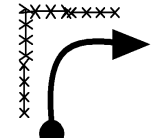
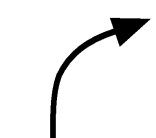

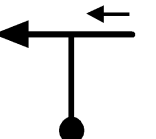
	<b>10.08</b>	
	V 39	02.09.23
	251	<b>T85</b>
	<b>10.19</b>	
	V 39	02.09.33
	252	<b>T85</b>
	<b>10.22</b>	
	V 39	02.09.36
	253	<b>T85</b>
	<b>10.61</b>	
	V 39	02.10.12
	254	<b>T85</b>
	<b>10.69</b>	
	V 39	02.10.20
	255	<b>T85</b>
	<b>10.98</b>	
	V 21	02.10.46
	256	<b>T86</b>
	<b>11.37</b>	
	V 42	02.11.53
	257	<b>T87</b>
	<b>11.52</b>	
	V 42	02.12.06
	258	<b>T87</b>

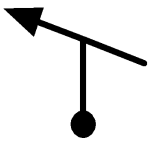
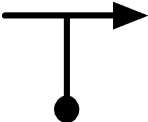
	11.83	
	0.00	
	V 39	02.12.33
	259	<b>T88</b>
	0.23	
	V 39	02.12.54
	260	<b>T88</b>
	0.33	
	V 39	02.13.03
	261	<b>T88</b>
	0.36	
	V 39	02.13.06
	262	<b>T88</b>
	0.75	
	N 1'	02.13.42
	263	<b>T89</b>
	0.75	
	V 30	02.14.42
	264	<b>T90</b>
	0.82	
	V 30	02.14.50
	265	<b>T90</b>
	0.95	
	V 30	02.15.06
	266	<b>T90</b>

	1.05	
	V 30	02.15.18
	267	<b>T90</b>
	1.24	
	V 30	02.15.41
	268	<b>T90</b>
	1.56	
	V 33	02.16.19
	269	<b>T91</b>
	1.76	
	V 33	02.16.41
	270	<b>T91</b>
	2.17	
	V 33	02.17.26
	271	<b>T91</b>
	2.37	
	V 42	02.17.47
	272	<b>T92</b>
	2.87	
	V 42	02.18.30
	273	<b>T92</b>
	3.17	
	V 42	02.18.56
	274	<b>T92</b>

	3.52	
	V 27	02.19.26
	275	<b>T93</b>
<del>X(6)</del> <del>X(6)</del>		
	3.60	
	V 27	02.19.37
	276	<b>T93</b>
<del>X(6)</del> <del>X(6)</del>		
	3.69	
	V 27	02.19.49
	277	<b>T93</b>
	3.75	
	V 27	02.19.57
	278	<b>T93</b>
	3.87	
	V 27	02.20.13
	279	<b>T93</b>
	4.04	
	V 33	02.20.35
	280	<b>T94</b>
	4.25	
	V 33	02.20.58
	281	<b>T94</b>
	4.35	
	V 33	02.21.09
	282	<b>T94</b>

	4.74	
	V 39	02.21.52
	283	<b>T95</b>
		
	4.89	
	V 30	02.22.05
	284	<b>T96</b>
	4.94	
	V 30	02.22.11
	285	<b>T96</b>
	5.00	
	V 30	02.22.19
	286	<b>T96</b>
	5.06	
	V 30	02.22.26
	287	<b>T96</b>
	5.22	
	V 30	02.22.45
	288	<b>T96</b>
	5.40	
	N 1'	02.23.07
	289	<b>T97</b>
		
	5.40	
	V 39	02.24.07
	290	<b>T98</b>

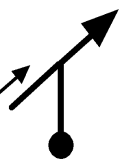
	5.65	
	V 33	02.24.30
	291	<b>T99</b>
	5.79	
	V 33	02.24.45
	292	<b>T99</b>
	5.82	
	V 33	02.24.48
	293	<b>T99</b>
		
	5.91	
	V 33	02.24.58
	294	<b>T99</b>
	5.96	
	V 45	02.25.04
	295	<b>T100</b>
	6.03	
	V 45	02.25.09
	296	<b>T100</b>
	6.48	
	V 27	02.25.45
	297	<b>T101</b>
		
	6.66	
	V 27	02.26.09
	298	<b>T101</b>



	<b>7.02</b>	
	V 33	02.26.57
	299	<b>T102</b>



	<b>7.32</b>	
	V 27	02.27.30
	300	<b>T103</b>





	<b>7.53</b>	
	V 27	02.27.58
	301	<b>T103</b>





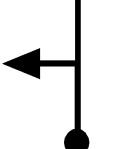
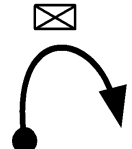

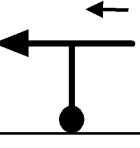
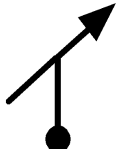
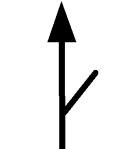
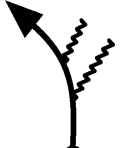

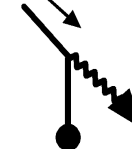
	<b>7.75</b>	
	V 39	02.28.27
	302	<b>T104</b>

	<b>7.83</b>	
	V 39	02.28.35
	303	<b>T104</b>

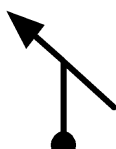
	<b>8.09</b>	
	V 33	02.28.59
	304	<b>T105</b>

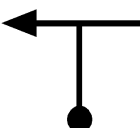
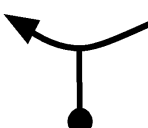
	<b>8.22</b>	
	V 33	02.29.13
	305	<b>T105</b>

	8.25	
	V 33	02.29.16
	306	<b>T105</b>
	8.40	
	V 33	02.29.32
	307	<b>T105</b>
	8.55	
	N1'30s	02.29.49
	308	<b>T106</b>
	8.55	
	V 33	02.31.19
	309	<b>T107</b>
	8.60	
	V 45	02.31.24
	310	<b>T108</b>
	8.68	
	V 45	02.31.31
	311	<b>T108</b>
	9.12	
	V 39	02.32.06
	312	<b>T109</b>
		
	9.36	
	V 27	02.32.28
	313	<b>T110</b>

	
	<b>9.44</b>
	V 27 02.32.39
	314 <b>T110</b>
	<b>9.79</b>
	V 27 02.33.25
	315 <b>T110</b>
	
	<b>9.92</b>
	V 27 02.33.43
	316 <b>T110</b>
	<b>10.14</b>
	<b>0.00</b>
	V 42 02.34.12
	317 <b>T111</b>
<b>MUITO CUIDADO - MOTO CONTRA</b>	
<b>MOTO CONTRA</b>	
	
	<b>0.17</b>
	V 42 02.34.27
	318 <b>T111</b>
	<b>0.51</b>
	V 42 02.34.56
	319 <b>T111</b>

	<b>0.65</b>	
	V 33	02.35.08
	320	<b>T112</b>
	<b>0.67</b>	
	V 33	02.35.10
	321	<b>T112</b>
	<b>0.78</b>	
	V 33	02.35.22
	322	<b>T112</b>
	<b>1.11</b>	
	V 27	02.35.58
	323	<b>T113</b>
	<b>1.15</b>	
	V 27	02.36.03
	324	<b>T113</b>
RIO		
	<b>1.20</b>	
	V 27	02.36.10
	325	<b>T113</b>
	<b>1.28</b>	
	V 30	02.36.21
	326	<b>T114</b>
	<b>1.41</b>	
	V 30	02.36.36
	327	<b>T114</b>

	1.46	
	V 30	02.36.42
	328	<b>T114</b>
	1.60	
	V 30	02.36.59
	329	<b>T114</b>
	1.77	
	V 30	02.37.19
	330	<b>T114</b>
	1.86	
	V 45	02.37.30
	331	<b>T115</b>
	1.95	
	V 45	02.37.37
	332	<b>T115</b>
	2.30	
	N 1'	02.38.05
	333	<b>T116</b>
	2.30	
	V 18	02.39.05
	334	<b>T117</b>
	2.33	
	V 18	02.39.11
	335	<b>T117</b>

	2.42
	V 42 02.39.29
	336 <b>T118</b>
	2.75
	V 42 02.39.58
	337 <b>T118</b>
	2.90
	V 21 02.40.10
	338 <b>T119</b>
	3.00
	V 27 02.40.28
	339 <b>T120</b>
CUIDADO	
ATOLEIRO	
	3.24
	V 24 02.41.00
	340 <b>T121</b>
	3.28
	V 24 02.41.06
	341 <b>T121</b>
	3.87
	V 24 02.42.34
	342 <b>T121</b>
	3.90
	V 39 02.42.39
	343 <b>T122</b>

	5.41	
	V 39	02.44.58
	344	<b>T122</b>
	6.19	
	V 39	02.46.10
	345	<b>T122</b>
	6.26	
	V 24	02.46.16
	346	<b>T123</b>
	6.57	
	V 27	02.47.03
	347	<b>T124</b>
	6.92	
	V 27	02.47.50
	348	<b>T124</b>
	7.11	
	V 39	02.48.15
	349	<b>T125</b>
	7.49	
	V 27	02.48.50
	350	<b>T126</b>
BAMP		
	7.60	
	V 27	02.49.05
	351	<b>T126</b>

	7.73
	V 39 02.49.22
	352 <b>T127</b>
	7.75
	V 39 02.49.24
	353 <b>T127</b>
	8.18
	V 45 02.50.04
	354 <b>T128</b>
BAMP	
	8.56
	V 27 02.50.34
	355 <b>T129</b>
	8.69
	V 27 02.50.51
	356 <b>T129</b>
	8.75
	V 27 02.50.59
	357 <b>T129</b>
	8.79
	V 9 02.51.05
	358 <b>T130</b>
SIGA PELO RIO	
	8.81
	V 9 02.51.13
	359 <b>T130</b>



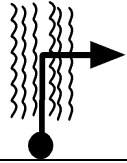

8.82

V 9 02.51.17

360 T130

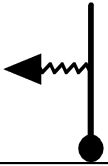

8.83

V 9 02.51.21

361 T130

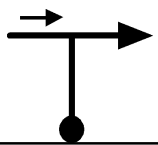

8.84

V 45 02.51.25

362 T131

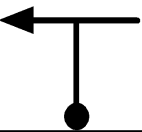

9.13

V 45 02.51.48

363 T131

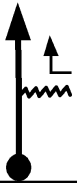

10.05

V 45 02.53.01

364 T131

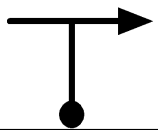

10.33

V 45 02.53.24

365 T131

**FIM DE PROVA !!**



[www.t15.com.br](http://www.t15.com.br)

A EQUIPE BICHO DO MATO  
AGRADECE O SEU  
COMPARECIMENTO.

**Tempo de Prova**

GRADUADOS 02:53:24

**FIM**