

# INICIO

## MÉDIA A

COPA MTC - SIDERÓPOLIS  
EQUIPE BICHO DO MATO



## IMPORTANTE

A PLANILHA POSSUI 4  
MÉDIAS.  
EM CONDIÇÕES NORMAIS DE  
TEMPO

Média "A" para Graduados  
Média "B" para Over 40 e  
Júnior

Média "C" para Over 45,  
Duplas e Estreantes

EM CASO DE MÉDIA DE  
CHUVA

Média "B" para Graduados  
Média "C" para Over 40 e  
Júnior

Média "D" para Over 45,  
Duplas e Estreantes

A DECISÃO É DA  
ORGANIZAÇÃO DA PROVA ATÉ  
3 HORAS DA LARGADA!!



**CUIDADO**



**ATENÇÃO**



**MUITA ATENÇÃO**





# Tempo de Prova

MÉDIA A 02:58:37

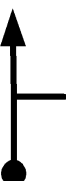

## AFERIÇÃO

ZERAR NO POSTE

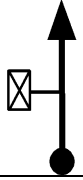
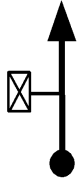
	0.00		
		1	AFER
	0.34		
		2	AFER
	0.60		
		3	AFER
	0.84		
		4	AFER
	1.46		
		5	AFER
FINAL DA AFERIÇÃO			
RETORNE PARA A LARGADA			
	1.60		
	0.00		
		6	AFER



## INICIO DE PROVA

	0.00
	V 36 00.00.00
	7 T1

	0.11
	V 36 00.00.11
	8 T1

	0.19
	V 36 00.00.19
	9 T1

	0.27
	V 36 00.00.27
	10 T1



	0.45
	V 36 00.00.45
	11 T1

	0.72
	V 36 00.01.12
	12 T1

DEVAGAR

	1.03
	V 15 00.01.43
	13 T2

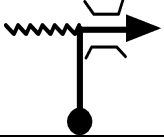
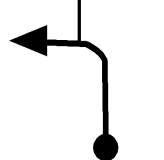
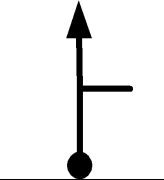
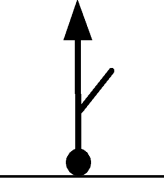
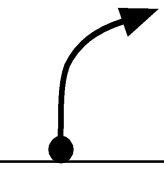
	1.20
	V 39 00.02.24
	14 T3
	1.60
	V 39 00.03.01
	15 T3
	1.76
	V 39 00.03.15
	16 T3
	2.09
	V 39 00.03.46
	17 T3
	2.58
	V 39 00.04.31
	18 T3
	2.68
	V 39 00.04.40
	19 T3
	2.79
	V 39 00.04.51
	20 T3
	3.06
	V 39 00.05.15
	21 T3

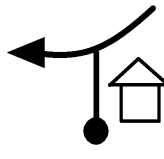
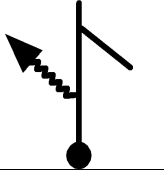





	3.30	
	V 39	00.05.38
	22	<b>T3</b>
	3.40	
	V 39	00.05.47
	23	<b>T3</b>
	3.42	
	V 39	00.05.49
	24	<b>T3</b>
	3.46	
	V 39	00.05.52
	25	<b>T3</b>
	3.53	
	V 39	00.05.59
	26	<b>T3</b>
	3.81	
	N 30s	00.06.25
	27	<b>T4</b>
	3.81	
	V 39	00.06.55
	28	<b>T5</b>
	4.01	
	V 30	00.07.13
	29	<b>T6</b>

	4.11
	V 30 00.07.25
	30 T6
	4.30
	V 30 00.07.48
	31 T6
	4.62
	V 42 00.08.26
	32 T7
	4.81
	V 42 00.08.43
	33 T7
	5.43
	V 42 00.09.36
	34 T7
	5.92
	V 42 00.10.18
	35 T7
	6.22
	V 42 00.10.44
	36 T7
	6.46
	V 42 00.11.04
	37 T7

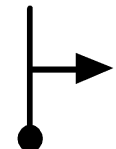
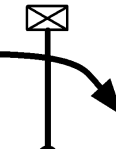
	<b>6.58</b>	
	V 42	00.11.14
	38	T7
	<b>6.65</b>	
	V 42	00.11.20
	39	T7
	<b>6.66</b>	
	V 42	00.11.21
	40	T7
	<b>6.90</b>	
	V 42	00.11.42
	41	T7
	<b>7.04</b>	
	V 42	00.11.54
	42	T7
	<b>7.36</b>	
	V 42	00.12.21
	43	T7
	<b>7.97</b>	
	V 42	00.13.14
	44	T7
	<b>8.07</b>	
	V 42	00.13.22
	45	T7

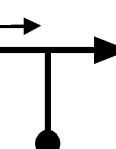
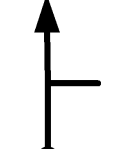
	8.22
	0.00
	V 42 00.13.35
	46 T8
	0.35
	V 42 00.14.05
	47 T8
	0.42
	V 30 00.14.11
	48 T9
	0.51
	V 30 00.14.22
	49 T9
	0.70
	V 42 00.14.45
	50 T10
	0.84
	V 42 00.14.57
	51 T10
	1.24
	V 42 00.15.31
	52 T10
	1.29
	V 42 00.15.35
	53 T10

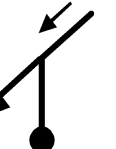

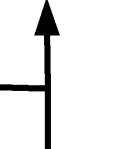
	1.38
	V 42 00.15.43
	54 <b>T10</b>
	1.53
	V 42 00.15.56
	55 <b>T10</b>
	
	1.68
	N 2' 00.16.09
	56 <b>T11</b>
	1.68
	V 42 00.18.09
	57 <b>T12</b>
	1.77
	V 42 00.18.16
	58 <b>T12</b>
	
	1.80
	V 51 00.18.19
	59 <b>T13</b>
	
	2.17
	V 51 00.18.45
	60 <b>T14</b>

	2.28	
	V 36	00.18.53
	61	<b>T15</b>
	2.47	
	V 36	00.19.12
	62	<b>T15</b>
	2.66	
	V 39	00.19.31
	63	<b>T16</b>
	2.68	
	V 39	00.19.33
	64	<b>T16</b>
	2.78	
	V 39	00.19.42
	65	<b>T16</b>
	2.99	
	V 30	00.20.01
	66	<b>T17</b>
	3.16	
	V 30	00.20.22
	67	<b>T17</b>
	3.27	
	V 30	00.20.35
	68	<b>T17</b>



	3.34
	V 30 00.20.43
	69 T17
	3.52
	V 42 00.21.05
	70 T18
	3.66
	V 42 00.21.17
	71 T18
	4.06
	V 42 00.21.51
	72 T18
	4.11
	V 42 00.21.55
	73 T18
	4.20
	V 42 00.22.03
	74 T18
	4.23
	V 36 00.22.06
	75 T19
	4.35
	V 36 00.22.18
	76 T19



4.44

N 2' 00.22.27

77

**T20**

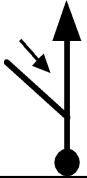

4.44

V 51 00.24.27

78

**T21**

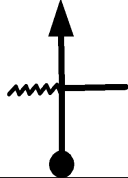

4.92

V 15 00.25.00

79

**T22**

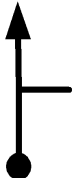

5.06

V 15 00.25.34

80

**T22**

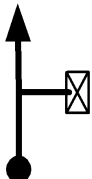

5.12

V 42 00.25.48

81

**T23**

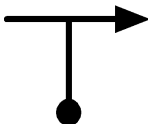

5.44

V 42 00.26.16

82

**T23**



5.47

V 42 00.26.18

83

**T23**









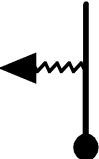

5.80

V 39 00.26.47

84

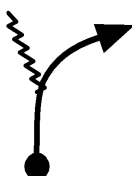
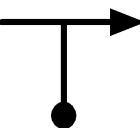
**T24**

	<b>6.29</b>
	V 39   00.27.32
	85   <b>T24</b>
	<b>6.41</b>
	V 39   00.27.43
	86   <b>T24</b>
<b>ACELERE!!!!</b>	
	<b>6.68</b>
	V 39   00.28.08
	87   <b>T24</b>
	<b>6.82</b>
	V 39   00.28.21
	88   <b>T24</b>
	<b>6.83</b>
	V 39   00.28.22
	89   <b>T24</b>
<b>PERIGO</b>	
	
	<b>6.91</b>
	V 39   00.28.29
	90   <b>T24</b>
	<b>7.05</b>
	V 39   00.28.42
	91   <b>T24</b>
	
	<b>7.07</b>
	V 39   00.28.44
	92   <b>T24</b>







	<b>7.22</b>	
	V 39	00.28.58
	93	<b>T24</b>
	<b>7.26</b>	
	V 39	00.29.02
	94	<b>T24</b>
	<b>7.29</b>	
	V 39	00.29.04
	95	<b>T24</b>
PERIGO NÃO ERRE		
	<b>7.56</b>	
	V 39	00.29.29
	96	<b>T24</b>
	<b>7.87</b>	
	V 39	00.29.58
	97	<b>T24</b>
	<b>7.91</b>	
	V 39	00.30.02
	98	<b>T24</b>
	<b>8.01</b>	
	V 27	00.30.11
	99	<b>T25</b>
	<b>8.21</b>	
	V 36	00.30.37
	100	<b>T26</b>



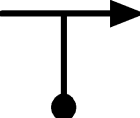

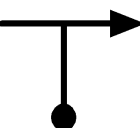
	8.40
	V 36 00.30.56
	101 T26
	8.54
	N 3' 00.31.10
	102 T27
	8.54
	V 39 00.34.10
	103 T28
	8.70
	V 39 00.34.25
	104 T28
<b>PERIGO</b>	
	9.03
	V 39 00.34.56
	105 T28
	9.34
	V 39 00.35.24
	106 T28
	9.48
	V 39 00.35.37
	107 T28
	9.76
	V 39 00.36.03
	108 T28

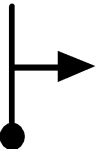

	9.88
	0.00
	N 1' 00.36.14
	109 <b>T29</b>
	0.00
	V 39 00.37.14
	110 <b>T30</b>
	0.30
	V 39 00.37.42
	111 <b>T30</b>
	0.44
	V 27 00.37.55
	112 <b>T31</b>
	0.64
	V 36 00.38.21
	113 <b>T32</b>
	0.83
	V 42 00.38.40
	114 <b>T33</b>
	0.85
	V 42 00.38.42
	115 <b>T33</b>
	1.14
	V 36 00.39.07
	116 <b>T34</b>

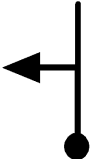

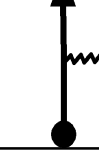
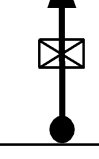
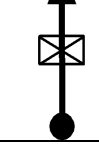
	1.48
	V 36 00.39.41
	117 T34
	1.88
	V 36 00.40.21
	118 T34
	1.96
	N1'30s 00.40.29
	119 T35
	
	1.96
	V 42 00.41.59
	120 T36
	3.10
	V 42 00.43.37
	121 T36
	3.94
	V 42 00.44.49
	122 T36
	4.08
	V 42 00.45.01
	123 T36

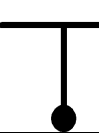
	4.09	
	V 42	00.45.02
	124	<b>T36</b>
	4.10	
	V 42	00.45.02
	125	<b>T36</b>
	4.48	
	V 24	00.45.35
	126	<b>T37</b>
	5.08	
	V 24	00.47.05
	127	<b>T37</b>
	5.87	
	V 24	00.49.03
	128	<b>T37</b>
	5.98	
	V 24	00.49.20
	129	<b>T37</b>
	6.07	
	N 3'	00.49.33
	130	<b>T38</b>
	6.07	
	V 24	00.52.33
	131	<b>T39</b>

	6.13	
	V 21	00.52.42
	132	<b>T40</b>
	6.38	
	V 21	00.53.25
	133	<b>T40</b>
	6.58	
	V 21	00.54.00
	134	<b>T40</b>
	6.94	
	V 39	00.55.01
	135	<b>T41</b>
	6.95	
	V 39	00.55.02
	136	<b>T41</b>
	6.97	
	V 39	00.55.04
	137	<b>T41</b>
	7.05	
	V 39	00.55.11
	138	<b>T41</b>
	8.12	
	<b>0.00</b>	
	V 54	00.56.50
	139	<b>T42</b>

	0.28
	V 54 00.57.09
	140 T42
	0.86
	V 45 00.57.48
	141 T43
	1.85
	V 39 00.59.07
	142 T44
	1.93
	V 39 00.59.14
	143 T44
	2.05
	V 39 00.59.25
	144 T44
	2.40
	V 39 00.59.58
	145 T44
	2.49
	V 39 01.00.06
	146 T44
	2.56
	V 33 01.00.12
	147 T45

PEDRA LISA



2.69

V 33 01.00.26

148

**T45**



2.74

V 27 01.00.32

149

**T46**

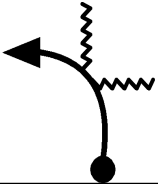

3.13

V 27 01.01.24

150

**T46**

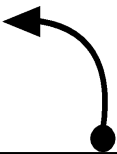

3.31

V 39 01.01.48

151

**T47**

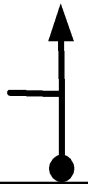

3.41

V 39 01.01.57

152

**T47**



3.50

V 39 01.02.05

153

**T47**

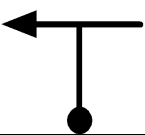

3.82

V 39 01.02.35

154

**T47**

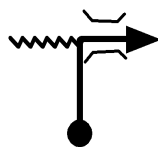









4.05

V 39 01.02.56

155

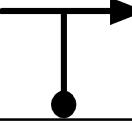
**T47**





	4.15	V 39	01.03.05
	156	T47	
	4.19	V 39	01.03.09
	157	T47	
	4.23	V 39	01.03.13
	158	T47	
	4.29	V 39	01.03.18
	159	T47	
	4.58	V 39	01.03.45
	160	T47	
	4.65	V 39	01.03.52
	161	T47	
	4.92	V 39	01.04.17
	162	T47	
	4.94	V 39	01.04.18
	163	T47	

	<b>5.04</b>	
	V 18	01.04.28
	164	<b>T48</b>
	<b>5.32</b>	
	V 18	01.05.24
	165	<b>T48</b>
	<b>5.48</b>	
	N 2'	01.05.56
	166	<b>T49</b>
	<b>5.48</b>	
	V 39	01.07.56
	167	<b>T50</b>
	<b>5.78</b>	
	V 39	01.08.23
	168	<b>T50</b>
	<b>6.26</b>	
	V 39	01.09.08
	169	<b>T50</b>
	<b>6.42</b>	
	V 39	01.09.22
	170	<b>T50</b>
	<b>7.09</b>	
	V 39	01.10.24
	171	<b>T50</b>

	7.24	V 39	01.10.38
	172	<b>T50</b>	
	7.45	V 30	01.10.57
	173	<b>T51</b>	
	7.53	V 30	01.11.07
	174	<b>T51</b>	
	7.58	V 30	01.11.13
	175	<b>T51</b>	
	7.66	N 1'	01.11.23
	176	<b>T52</b>	
	7.66	V 15	01.12.23
	177	<b>T53</b>	
	7.85	V 39	01.13.08
	178	<b>T54</b>	
	7.94	V 39	01.13.17
	179	<b>T54</b>	

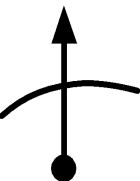



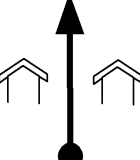





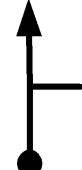

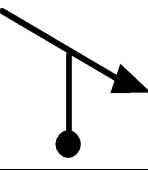
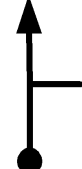
	8.44
	V 39 01.14.03
	180 T54
	8.69
	V 39 01.14.26
	181 T54
	8.77
	V 39 01.14.33
	182 T54
	8.89
	0.00
	N 20' 01.14.44
	183 T55
	0.00
	V 33 01.34.44
	184 T56
	0.59
	V 15 01.35.49
	185 T57
	0.70
	V 15 01.36.15
	186 T57

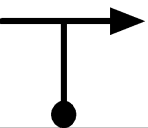
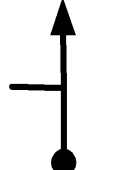



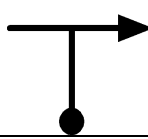

	0.74	
	V 33	01.36.25
	187	<b>T58</b>
	0.84	
	V 33	01.36.36
	188	<b>T58</b>
	0.92	
	V 33	01.36.44
	189	<b>T58</b>
	0.99	
	V 33	01.36.52
	190	<b>T58</b>
	1.04	
	V 33	01.36.57
	191	<b>T58</b>
	1.17	
	V 33	01.37.12
	192	<b>T58</b>
	1.40	
	V 18	01.37.37
	193	<b>T59</b>
	1.65	
	V 33	01.38.27
	194	<b>T60</b>

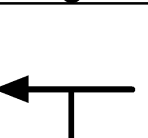
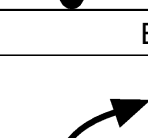
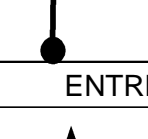
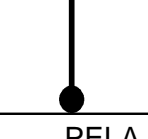

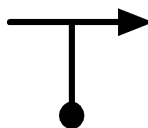

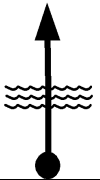
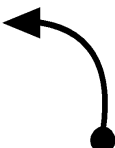
	<b>1.88</b>	
	V 33	01.38.52
	195	<b>T60</b>
	<b>1.92</b>	
	V 18	01.38.56
	196	<b>T61</b>
	<b>1.99</b>	
	V 33	01.39.10
	197	<b>T62</b>
<b>ATOLEIRO</b>		
<b>PELA ESQUERDA</b>		
	<b>2.45</b>	
	V 33	01.40.00
	198	<b>T62</b>
	<b>2.48</b>	
	V 33	01.40.04
	199	<b>T62</b>
	<b>2.56</b>	
	V 33	01.40.12
	200	<b>T62</b>
	<b>2.68</b>	
	V 42	01.40.25
	201	<b>T63</b>

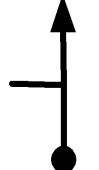
	<b>2.73</b>	
	V 42	01.40.30
	202	<b>T63</b>
	<b>2.80</b>	
	V 42	01.40.36
	203	<b>T63</b>
	<b>2.86</b>	
	V 42	01.40.41
	204	<b>T63</b>
	<b>2.97</b>	
	V 42	01.40.50
	205	<b>T63</b>
		
	<b>3.01</b>	
	V 42	01.40.54
	206	<b>T63</b>
	<b>3.39</b>	
	V 36	01.41.26
	207	<b>T64</b>
	<b>3.92</b>	
	V 27	01.42.19
	208	<b>T65</b>
<b>CUIDADO DESCE</b>		
		
	<b>4.00</b>	
	V 27	01.42.30
	209	<b>T65</b>

☠☠	
	<b>4.09</b>
	V 27 01.42.42
	210 <b>T65</b>
BAMP	
	<b>4.11</b>
	V 18 01.42.45
	211 <b>T66</b>
☠☠	
	<b>4.30</b>
	V 42 01.43.23
	212 <b>T67</b>
	<b>4.69</b>
	V 42 01.43.56
	213 <b>T67</b>
	<b>4.73</b>
	V 42 01.43.59
	214 <b>T67</b>
BAMP	
	<b>4.80</b>
	D 3' 01.44.05
	215 <b>T68</b>
	<b>4.99</b>
	216 <b>T68</b>

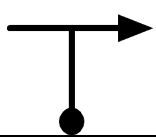
	5.04
	V 48 01.47.05
	217 <b>T69</b>
BAMP	
	5.31
	V 48 01.47.26
	218 <b>T69</b>
	5.34
	V 48 01.47.28
	219 <b>T69</b>
	5.47
	V 48 01.47.38
	220 <b>T69</b>
BAMP	
	5.53
	V 36 01.47.42
	221 <b>T70</b>
ENTRE NO MATO	
	5.57
	V 36 01.47.46
	222 <b>T70</b>
PELA ESQUERDA	
	5.81
	V 36 01.48.10
	223 <b>T70</b>

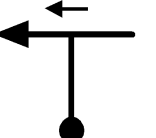
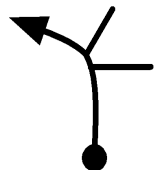
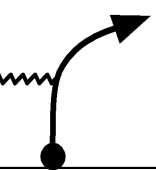

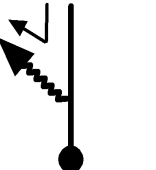
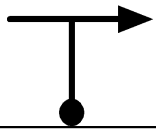
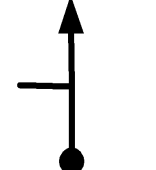

	6.04	
	V 36	01.48.33
	224	<b>T70</b>
	6.11	
	V 36	01.48.40
	225	<b>T70</b>
	6.13	
	V 36	01.48.42
	226	<b>T70</b>
	6.31	
	V 36	01.49.00
	227	<b>T70</b>
	6.38	
	V 36	01.49.07
	228	<b>T70</b>
	6.48	
	V 36	01.49.17
	229	<b>T70</b>
	6.55	
	V 42	01.49.24
	230	<b>T71</b>
	6.86	
	V 42	01.49.51
	231	<b>T71</b>

	<b>7.00</b>	
	V 42	01.50.03
	232	<b>T71</b>
		
	<b>7.15</b>	
	V 42	01.50.16
	233	<b>T71</b>
	<b>7.30</b>	
	V 42	01.50.28
	234	<b>T71</b>
	<b>7.45</b>	
	V 42	01.50.41
	235	<b>T71</b>
<b>CUIDADO</b>		
<b>CUIDADO</b>		
		
	<b>7.47</b>	
	V 21	01.50.43
	236	<b>T72</b>
	<b>7.69</b>	
	V 42	01.51.21
	237	<b>T73</b>
	<b>7.82</b>	
	V 42	01.51.32
	238	<b>T73</b>

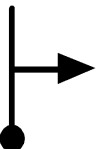
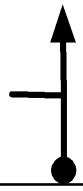

☠☠	
	7.96
	V 42 01.51.44
	239 T73
	7.99
	V 42 01.51.46
	240 T73
	8.03
	V 42 01.51.50
	241 T73
	9.12
	0.00
	V 36 01.53.23
	242 T74
	0.41
	V 36 01.54.04
	243 T74
	0.64
	V 36 01.54.27
	244 T74

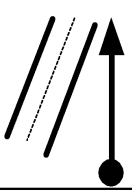
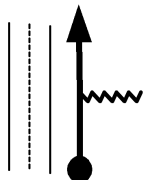
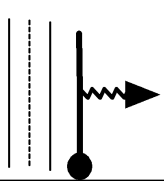
	1.24	
	V 36	01.55.27
	245	<b>T74</b>
	1.50	
	V 42	01.55.53
	246	<b>T75</b>
	1.53	
	V 42	01.55.56
	247	<b>T75</b>
<b>CUIDADO</b>		
<b>CUIDADO</b>		
	1.89	
	V 21	01.56.27
	248	<b>T76</b>
	2.10	
	V 42	01.57.03
	249	<b>T77</b>
	2.37	
	V 42	01.57.26
	250	<b>T77</b>
	2.40	
	V 42	01.57.28
	251	<b>T77</b>

	2.44	
	V 42	01.57.32
	252	<b>T77</b>
	3.01	
	V 42	01.58.21
	253	<b>T77</b>
	3.32	
	V 42	01.58.47
	254	<b>T77</b>
	3.47	
	V 42	01.59.00
	255	<b>T77</b>
COSTEAR		
ASFALTO		
	4.06	
	D 3'	01.59.51
	256	<b>T78</b>
	4.17	
	257	<b>T78</b>
	4.34	
	V 36	02.02.51
	258	<b>T79</b>
VALO		
		
	4.37	
	V 36	02.02.54
	259	<b>T79</b>

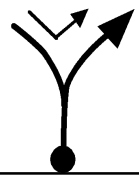

4.40

V 36 02.02.57

260

**T79**



4.57

V 36 02.03.14

261

**T79**



4.61

V 36 02.03.18

262

**T79**



4.64

V 36 02.03.21

263

**T79**



4.68

V 36 02.03.25

264

**T79**

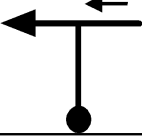

4.84

V 36 02.03.41

265

**T79**



5.04

V 36 02.04.01

266

**T79**

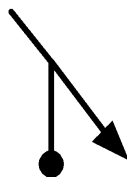

5.08

V 36 02.04.05

267

**T79**

	5.12	
	V 42	02.04.09
	268	<b>T80</b>
	5.32	
	V 42	02.04.26
	269	<b>T80</b>
	5.46	
	V 42	02.04.38
	270	<b>T80</b>
	5.61	
	V 42	02.04.51
	271	<b>T80</b>
<b>CUIDADO</b>		
<b>CUIDADO</b>		
	5.64	
	V 21	02.04.53
	272	<b>T81</b>
	5.86	
	V 42	02.05.31
	273	<b>T82</b>
	5.99	
	V 42	02.05.42
	274	<b>T82</b>

	<b>6.13</b>	
	V 42	02.05.54
	275	<b>T82</b>
	<b>6.16</b>	
	V 42	02.05.57
	276	<b>T82</b>
	<b>6.20</b>	
	V 42	02.06.00
	277	<b>T82</b>
	<b>6.76</b>	
	V 42	02.06.48
	278	<b>T82</b>
	<b>7.08</b>	
	V 42	02.07.16
	279	<b>T82</b>
	<b>7.22</b>	
	V 42	02.07.28
	280	<b>T82</b>
	<b>7.50</b>	
	N 2'	02.07.52
	281	<b>T83</b>
	<b>7.50</b>	
	V 27	02.09.52
	282	<b>T84</b>

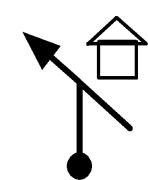
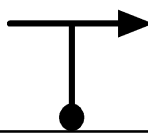
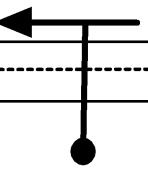
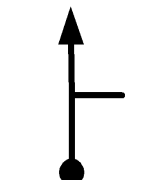
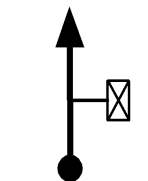
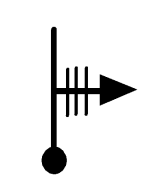
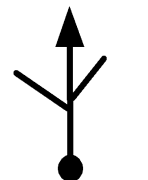
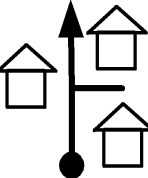
	7.80	
	V 27	02.10.32
	283	<b>T84</b>
	8.68	
	V 27	02.12.29
	284	<b>T84</b>
	8.74	
	D 5'	02.12.37
	285	<b>T85</b>
	9.14	
	286	<b>T85</b>
	9.71	
	287	<b>T85</b>
	9.75	
	0.00	
	V 15	02.17.37
	288	<b>T86</b>
	0.05	
	V 15	02.17.49
	289	<b>T86</b>
	0.10	
	V 15	02.18.01
	290	<b>T86</b>

## AÇUDE

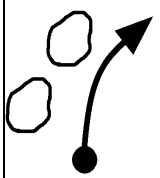

0.12

V 39 02.18.06

291

**T87**

0.23

V 39 02.18.16

292

**T87**

0.78

V 39 02.19.07

293

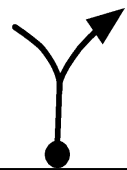
**T87**

0.82

V 39 02.19.10

294

**T87**

0.91

V 39 02.19.19

295

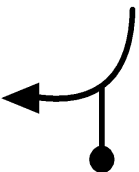
**T87**

1.22

V 39 02.19.47

296

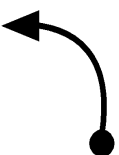
**T87**

1.49

V 39 02.20.12

297

**T87**

1.64

V 39 02.20.26

298

**T87**



	1.76	
	V 24	02.20.37
	299	<b>T88</b>



	1.96	
	N 1'	02.21.07
	300	<b>T89</b>



	1.96	
	V 39	02.22.07
	301	<b>T90</b>

	1.99	
	V 39	02.22.10
	302	<b>T90</b>







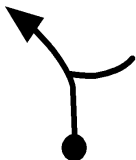

	2.09	
	V 39	02.22.19
	303	<b>T90</b>

	2.40	
	V 39	02.22.48
	304	<b>T90</b>

	2.66	
	V 39	02.23.12
	305	<b>T90</b>

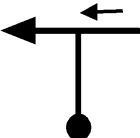
	<b>2.81</b>
	V 39 02.23.25
	306 <b>T90</b>
	<b>2.88</b>
	V 33 02.23.32
	307 <b>T91</b>
	<b>3.01</b>
	V 33 02.23.46
	308 <b>T91</b>
	<b>3.23</b>
	V 33 02.24.10
	309 <b>T91</b>
	<b>3.33</b>
	V 33 02.24.21
	310 <b>T91</b>
	<b>3.47</b>
	V 33 02.24.36
	311 <b>T91</b>
	<b>3.62</b>
	V 33 02.24.53
	312 <b>T91</b>

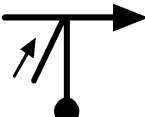
	3.65	
	V 33	02.24.56
	313	<b>T91</b>
	3.82	
	V 33	02.25.14
	314	<b>T91</b>
	3.96	
	V 33	02.25.30
	315	<b>T91</b>
	3.99	
	V 33	02.25.33
	316	<b>T91</b>
	4.06	
	V 33	02.25.41
	317	<b>T91</b>
	4.20	
	V 33	02.25.56
	318	<b>T91</b>
	4.36	
	V 33	02.26.13
	319	<b>T91</b>
	4.39	
	V 33	02.26.17
	320	<b>T91</b>

	4.56	
	N 2'	02.26.35
	321	<b>T92</b>
	4.56	
	V 36	02.28.35
	322	<b>T93</b>
	4.67	
	V 36	02.28.46
	323	<b>T93</b>
	4.94	
	V 36	02.29.13
	324	<b>T93</b>
		
	4.96	
	V 36	02.29.15
	325	<b>T93</b>
	5.09	
	V 24	02.29.28
	326	<b>T94</b>
		
	5.31	
	V 33	02.30.01
	327	<b>T95</b>
	5.36	
	V 33	02.30.07
	328	<b>T95</b>

☠☠	
	5.37
	V 33 02.30.08
	329 T95
☠☠	
	5.47
	V 24 02.30.19
	330 T96
☠☠	
	5.62
	V 33 02.30.41
	331 T97
☠☠	
	5.97
	V 33 02.31.19
	332 T97
☠☠	
	6.02
	V 33 02.31.25
	333 T97
☠☠	
	6.18
	V 33 02.31.42
	334 T97
☠☠	
	6.28
	V 33 02.31.53
	335 T97

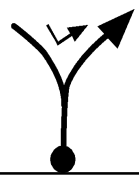

6.34

V 33 02.32.00

336

T97

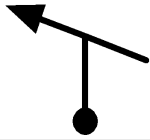

6.50

V 33 02.32.17

337

T97



6.55

V 33 02.32.23

338

T97

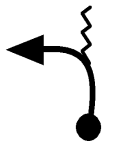

6.68

V 33 02.32.37

339

T97

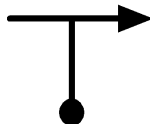

6.73

V 33 02.32.42

340

T97

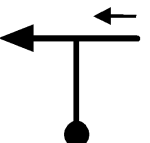

6.93

V 33 02.33.04

341

T97

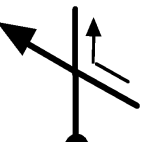

7.03

V 33 02.33.15

342

T97











7.08

V 33 02.33.20

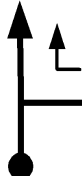
343

T97

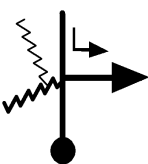
	<b>7.13</b>	
	V 33	02.33.26
	344	<b>T97</b>
	<b>7.16</b>	
	V 33	02.33.29
	345	<b>T97</b>
	<b>7.25</b>	
	V 33	02.33.39
	346	<b>T97</b>
	<b>7.28</b>	
	V 27	02.33.42
	347	<b>T98</b>
	<b>7.73</b>	
	V 27	02.34.42
	348	<b>T98</b>
	<b>7.77</b>	
	V 33	02.34.48
	349	<b>T99</b>
	<b>7.82</b>	
	V 33	02.34.53
	350	<b>T99</b>
	<b>7.98</b>	
	V 33	02.35.10
	351	<b>T99</b>

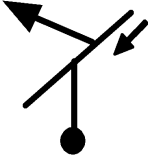
	<b>8.03</b>	
	N 2'	02.35.16
	352	<b>T100</b>
	<b>8.03</b>	
	V 33	02.37.16
	353	<b>T101</b>
		
	<b>8.12</b>	
	V 33	02.37.26
	354	<b>T101</b>
		
	<b>8.21</b>	
	V 33	02.37.36
	355	<b>T101</b>
		
	<b>8.24</b>	
	V 33	02.37.39
	356	<b>T101</b>
	<b>8.56</b>	
	V 33	02.38.14
	357	<b>T101</b>
		
	<b>9.01</b>	
	V 21	02.39.03
	358	<b>T102</b>

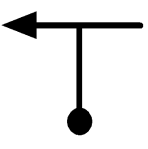

	9.20	
	0.00	
	V 39	02.39.35
	359	<b>T103</b>

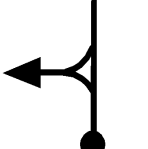

	0.61	
	V 39	02.40.32
	360	<b>T103</b>

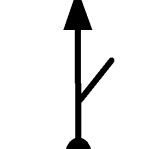
	0.69	
	V 39	02.40.39
	361	<b>T103</b>

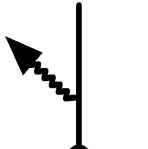

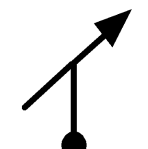

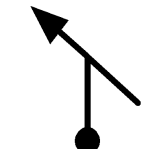

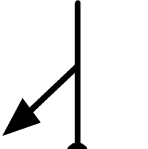
	0.71	
	V 39	02.40.41
	362	<b>T103</b>



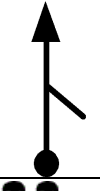

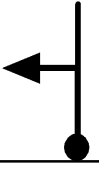

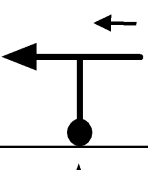
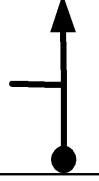
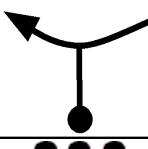
	0.76	
	V 39	02.40.46
	363	<b>T103</b>

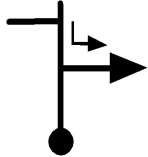
	0.84	
	V 39	02.40.53
	364	<b>T103</b>

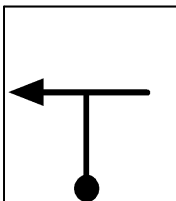
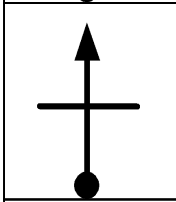
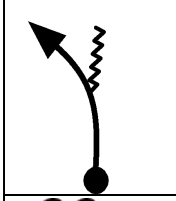
	1.04	
	V 36	02.41.11
	365	<b>T104</b>

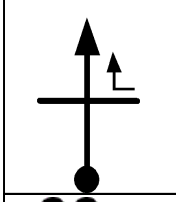
☠☠☠	
	1.11
	V 36   02.41.18
	366   <b>T104</b>
☠☠☠	
	1.87
	V 21   02.42.34
	367   <b>T105</b>
	2.07
	V 39   02.43.09
	368   <b>T106</b>
	2.15
	N 1'   02.43.16
	369   <b>T107</b>
	2.15
	V 39   02.44.16
	370   <b>T108</b>
	2.37
	V 39   02.44.36
	371   <b>T108</b>
	2.48
	V 21   02.44.47
	372   <b>T109</b>
ARVORE	
☠	
	2.55
	V 21   02.44.59
	373   <b>T109</b>

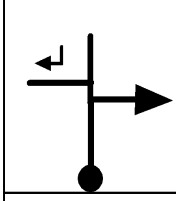
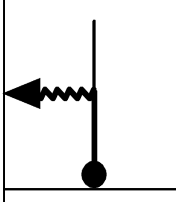
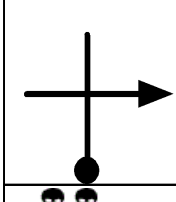
	2.70	
	V 27	02.45.24
	374	<b>T110</b>
		
	2.71	
	V 27	02.45.26
	375	<b>T110</b>
	2.77	
	V 27	02.45.34
	376	<b>T110</b>
	2.86	
	V 27	02.45.46
	377	<b>T110</b>
		
	2.99	
	V 27	02.46.03
	378	<b>T110</b>
	3.04	
	V 33	02.46.10
	379	<b>T111</b>
	3.07	
	V 33	02.46.13
	380	<b>T111</b>
		
	3.17	
	V 33	02.46.24
	381	<b>T111</b>

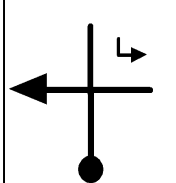
	<b>3.24</b>	
	V 33	02.46.31
	382	<b>T111</b>
	<b>3.38</b>	
	V 33	02.46.47
	383	<b>T111</b>
	<b>3.46</b>	
	V 33	02.46.55
	384	<b>T111</b>
		
	<b>3.76</b>	
	V 33	02.47.28
	385	<b>T111</b>
		
	<b>3.88</b>	
	V 33	02.47.41
	386	<b>T111</b>
	<b>3.99</b>	
	V 33	02.47.53
	387	<b>T111</b>
	<b>4.05</b>	
	V 33	02.48.00
	388	<b>T111</b>
		
	<b>4.10</b>	
	V 33	02.48.05
	389	<b>T111</b>

	4.16	
	V 21	02.48.12
	390	<b>T112</b>
	4.20	
	V 21	02.48.19
	391	<b>T112</b>
	4.23	
	V 21	02.48.24
	392	<b>T112</b>
PELA ESQUERDA		
ATOLEIRO		
	4.29	
	V 21	02.48.34
	393	<b>T112</b>
	4.52	
	V 33	02.49.13
	394	<b>T113</b>
	4.57	
	V 33	02.49.19
	395	<b>T113</b>
	4.64	
	V 33	02.49.27
	396	<b>T113</b>

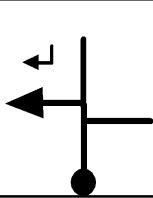

4.77

V 33 02.49.41

397 T113

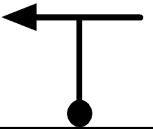

4.84

V 33 02.49.48

398 T113

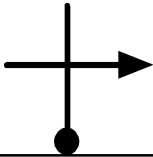

4.98

V 33 02.50.04

399 T113

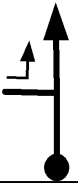

5.22

V 33 02.50.30

400 T113

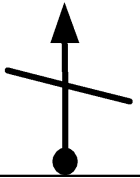

5.31

V 33 02.50.40

401 T113

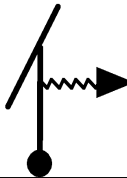

5.40

V 33 02.50.49

402 T113

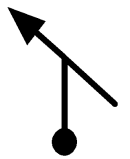

5.95

V 33 02.51.49

403 T113



6.21

V 33 02.52.18

404 T113

☠☠	
	6.23
	V 21 02.52.20
	405 <b>T114</b>
	6.41
	V 39 02.52.51
	406 <b>T115</b>
	7.03
	N 2' 02.53.48
	407 <b>T116</b>
	7.03
	V 15 02.55.48
	408 <b>T117</b>
	7.22
	V 30 02.56.34
	409 <b>T118</b>
	7.30
	V 30 02.56.43
	410 <b>T118</b>
	7.81
	V 30 02.57.44
	411 <b>T118</b>
	8.06
	V 30 02.58.14
	412 <b>T118</b>

	<b>8.14</b>	
	V 30	02:58.24
	413	<b>T118</b>
	<b>8.25</b>	
	V 30	02:58.37
	414	<b>T118</b>
<b>FIM DE PROVA !!</b>		
		
<a href="http://www.t15.com.br">www.t15.com.br</a>		
<b>Tempo de Prova</b>		
MÉDIA A 02:58:37		
<b>FIM</b>		