

# INICIO

## MÉDIA C

1º ENDURO DAS CACHOEIRAS  
04 DE NOVEMBRO DE 2017



## IMPORTANTE

O PILOTO QUE ANDAR SEM  
CAPACETE ANTES DA PROVA SERA  
PENALIZADO COM A  
DESCCLASSIFICAÇÃO.  
RESPEITE AS ROÇAS PARA TERMOS  
TRILHAS.

CUIDADO

ATENÇÃO

MUITA ATENÇÃO

## Tempo de Prova

MÉDIA C 03:19:21



## AFERIÇÃO

INICIO AFERIÇÃO

0.00		1	AFER
0.63		2	AFER
0.80		3	AFER

1.04		4	AFER
1.11		5	AFER
1.86		6	AFER
2.20		7	AFER
2.23		8	AFER

EUCALIPTO  
COM BAMP

FIM DA AFERIÇÃO  
VOLTE AO INICIO  
COM CUIDADO

2.45		9	AFER
0.00			



## INÍCIO DE PROVA



0.00		10	V	T1	42 00.00.00
CUIDADO MOTOS					

1.33		11	V	T2	33 00.01.54
1.37		12	V	T2	33 00.01.58
1.39		13	V	T2	33 00.02.01
3.09		14	V	T2	33 00.05.06
3.15		15	V	T2	33 00.05.13
3.66		16	V	T2	33 00.06.08
3.74		17	V	T3	27 00.06.17
3.96		18	V	T3	27 00.06.46
4.22		19	V	T4	15 00.07.21
4.26		20	V	T4	15 00.07.30
4.48		21	V	T5	27 00.08.23

04 DE NOVEMBRO DE 2017		Pág: 003	
<b>4.75</b>		27	00.08.59
		V	T5
<b>4.87</b>		27	00.09.15
		V	T5
<b>4.90</b>		27	00.09.19
		V	T5
<b>4.99</b>		21	00.09.31
		V	T6
CUIDADO MOTOS			
<b>5.07</b>		21	00.09.45
		V	T6
<b>5.10</b>		21	00.09.50
		V	T6
<b>5.19</b>		21	00.10.06
		V	T6
<b>5.28</b>		21	00.10.21
		V	T6
<b>5.53</b>		21	00.11.04
		V	T6
CUIDADO			
DESCIDA LISA			
<b>5.56</b>		15	00.11.09
		V	T7

04 DE NOVEMBRO DE 2017		Pág: 004	
<b>5.64</b>		15	00.11.28
		V	T7
<b>5.72</b>		15	00.11.47
		V	T7
<b>5.85</b>		9	00.12.19
		V	T8
<b>5.89</b>		9	00.12.35
		V	T8
<b>5.99</b>		1'30s	00.13.15
<b>0.00</b>		N	T9
<b>0.00</b>		33	00.14.45
		V	T10
<b>0.50</b>		33	00.15.39
		V	T10
<b>0.58</b>		24	00.15.48
		V	T11
<b>0.80</b>		24	00.16.21
		V	T11
<b>1.07</b>		24	00.17.01
		V	T11
<b>1.19</b>		24	00.17.19
		V	T11

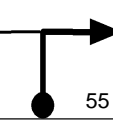
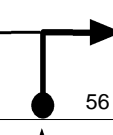
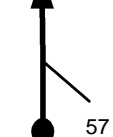
04 DE NOVEMBRO DE 2017		Pág: 005	
<b>1.22</b>		24	00.17.24
		V	T11
<b>1.31</b>		24	00.17.37
		V	T11
<b>1.40</b>		21	00.17.51
		V	T12
<b>1.48</b>		21	00.18.05
		V	T12
<b>1.59</b>		21	00.18.23
		V	T12
<b>1.65</b>		21	00.18.34
		V	T12
<b>1.84</b>		21	00.19.06
		V	T12
<b>1.93</b>		21	00.19.22
		V	T12
<b>1.97</b>		21	00.19.29
		V	T12
<b>2.08</b>		21	00.19.47
		V	T12
<b>2.28</b>		21	00.20.22
		V	T12

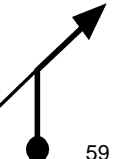



<b>2.34</b>		21	00.20.32
		V	T12
<b>2.44</b>		21	00.20.49
		V	T12
<b>2.47</b>		21	00.20.54
		V	T12
<b>2.58</b>		21	00.21.13
		V	T12
<b>2.88</b>		27	00.22.05
		V	T13
<b>3.08</b>		27	00.22.31
		V	T13

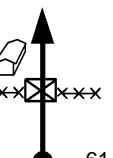

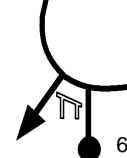
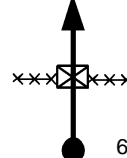
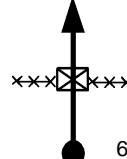
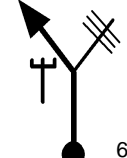

<b>3.94</b>		12	00.24.26
		V	T14
DEVAGAR			
RESPEITE AS CASAS			

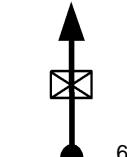
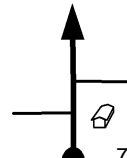
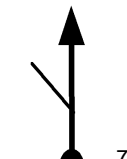

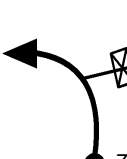
<b>4.02</b>		12	00.24.50
		V	T14

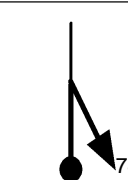
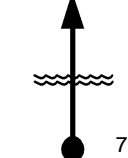
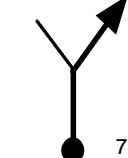
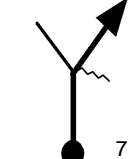
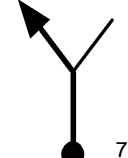
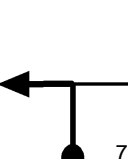
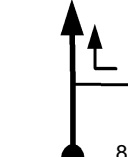
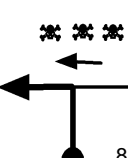
<b>4.18</b>		1'30	00.25.38
		N	T15

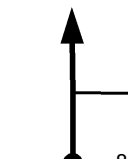

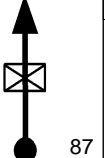
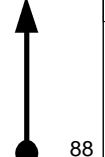
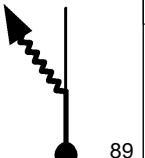
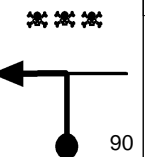
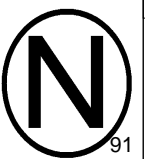
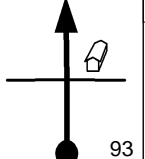

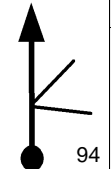
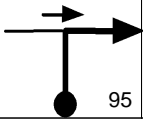
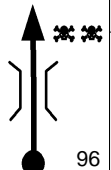
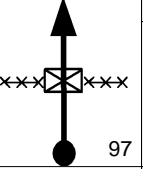
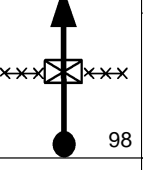
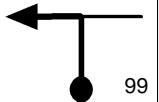
<b>4.18</b>		30	00.27.08
		V	T16
<b>4.35</b>		30	00.27.28
		V	T16
<b>5.00</b>		30	00.28.46
		V	T16
<b>5.10</b>		30	00.28.58
		V	T16
<b>5.17</b>		30	00.29.07
		V	T16
<b>5.22</b>		30	00.29.13
		V	T16
<b>5.43</b>		18	00.29.38
		V	T17
<b>6.56</b>		30	00.33.24
		V	T18
<b>6.67</b>		30	00.33.37
		V	T18
<b>7.00</b>		30	00.34.17
		V	T18
<b>7.47</b>		30	00.35.13
		V	T18

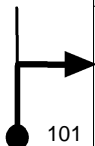
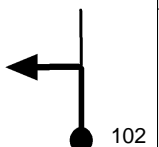
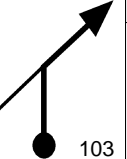
<b>7.73</b>		24	00.35.44
		V	T19
<b>7.79</b>		24	00.35.53
		V	T19
<b>7.84</b>		24	00.36.01
		V	T19
<b>8.26</b>		24	00.37.04
		V	T19
<b>8.41</b>		24	00.37.26
		V	T19
<b>8.68</b>		24	00.38.07
		V	T19
<b>8.75</b>		24	00.38.17
		V	T19
<b>9.71</b>		1'	00.40.41
<b>0.00</b>		N	T20
<b>0.00</b>		33	00.41.41
		V	T21
<b>0.06</b>		33	00.41.48
		V	T21
<b>0.09</b>		33	00.41.51
		V	T21

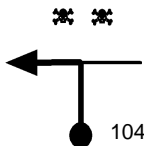
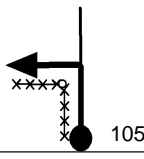
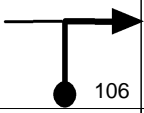
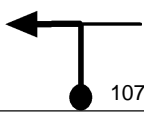
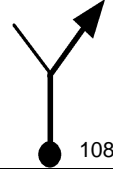
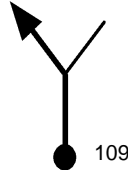
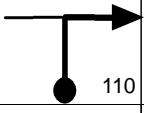
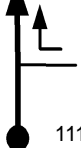
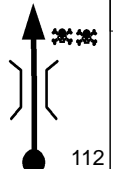
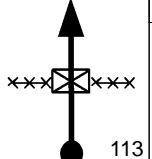
<b>1.56</b>		24	00.44.32
		V	<b>T22</b>
<b>1.84</b>		24	00.45.14
		V	T22
<b>1.87</b>		24	00.45.18
		V	T22
RESPEITE AS ROÇAS			
<b>1.92</b>		18	00.45.26
		V	<b>T23</b>
<b>2.03</b>		24	00.45.48
		V	<b>T24</b>
CUIDADO PERIGO			
ACERTAR ODOMETRO LARGAR DO NEUTRO COM 0,11			
<b>2.37</b> <b>0.00</b>		1'	00.46.38
		N	<b>T25</b>
<b>0.00</b>		45	00.47.38
		V	<b>T26</b>
<b>0.65</b>		24	00.48.30
		V	<b>T27</b>
<b>1.72</b>		24	00.51.11
		V	T27

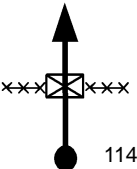
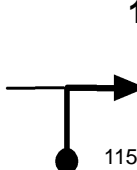

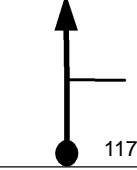
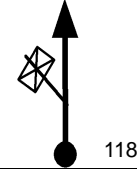
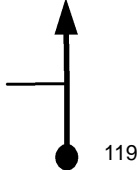

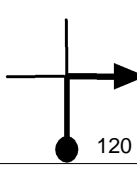
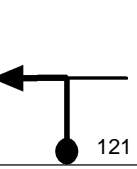
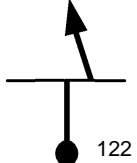

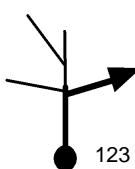
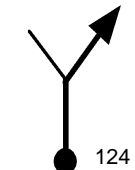
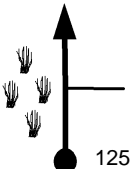
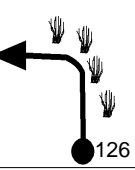
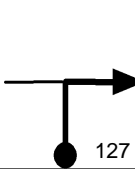
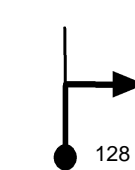
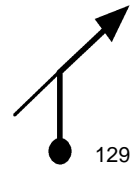
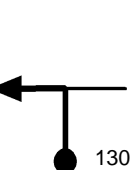
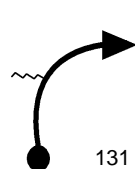
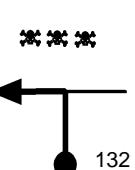
<b>1.83</b>		24	00.51.28
		V	T27
<b>1.98</b>		18	00.51.50
		V	<b>T28</b>
CUIDADO PERIGO			
<b>2.33</b>		21	00.53.00
		V	<b>T29</b>
<b>2.80</b>		21	00.54.21
		V	T29
<b>2.92</b>		21	00.54.41
		V	T29
<b>3.01</b>		1'	00.54.57
		N	<b>T30</b>
<b>3.01</b>		36	00.55.57
		V	<b>T31</b>
<b>3.57</b>		36	00.56.59
		V	T31
<b>3.63</b>		V	T31
		36	00.57.06
<b>3.70</b>		V	T31

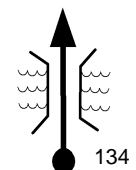
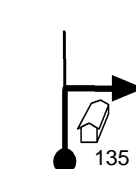
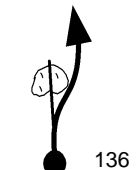
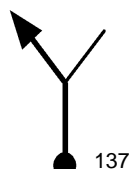
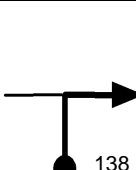
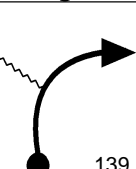
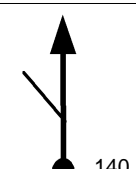
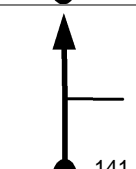
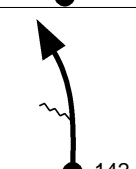
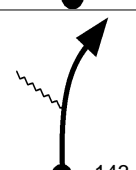



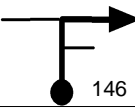
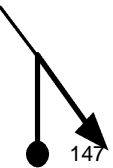
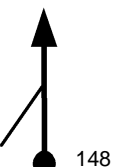

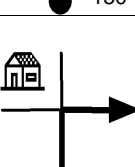
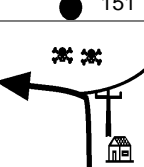

<b>3.74</b>		36	00.57.10
		V	T31
<b>4.47</b>		27	00.58.23
		V	<b>T32</b>
<b>4.62</b>		27	00.58.43
		V	T32
<b>4.66</b>		21	00.58.48
		V	<b>T33</b>
<b>4.73</b>		21	00.59.00
		V	T33
<b>4.74</b>		21	00.59.02
		V	T33
<b>4.75</b>		21	00.59.03
		V	T33
<b>5.77</b>		18	01.01.58
		V	<b>T34</b>
CUIDADO PERIGO			
<b>6.12</b>		21	01.03.08
		V	<b>T35</b>
<b>6.59</b>		21	01.04.29
		V	T35



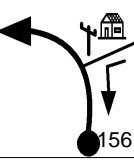
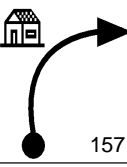

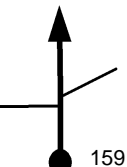



<b>6.71</b>		21	01.04.49
		V	T35
<b>6.80</b>		1'30s	01.05.05
		N	T36
<b>6.80</b>		27	01.06.35
		V	T37
<b>6.86</b>		27	01.06.43
		V	T37
<b>7.05</b>		27	01.07.08
		V	T37
<b>8.00</b>		27	01.09.15
		V	T37
			
<b>8.03</b>		18	01.09.19
		V	T38
<b>8.07</b>		18	01.09.27
		V	T38
<b>8.12</b>		18	01.09.37
		V	T38

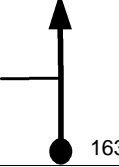

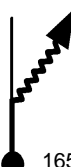
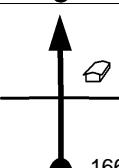
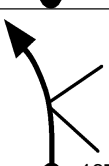

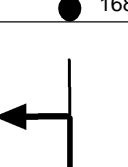
<b>8.37</b>		24	01.10.27
		V	T39
<b>8.44</b>		24	01.10.37
		V	T39
<b>8.56</b>		24	01.10.55
		V	T39
RESPEITE AS ROÇAS			
<b>8.66</b>		24	01.11.10
		V	T39
<b>8.70</b>		24	01.11.16
		V	T39
<b>8.71</b>		24	01.11.18
		V	T39
<b>8.76</b>		24	01.11.25
		V	T39
<b>9.41</b>		24	01.13.03
		V	T39
<b>9.67</b>		24	01.13.42
		V	T39
<b>9.99</b>		1'	01.14.30
<b>0.00</b>		N	T40

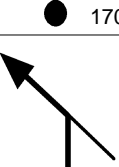

<b>0.00</b>		33	01.15.30
		V	T41
<b>0.07</b>		33	01.15.37
		V	T41
<b>0.20</b>		24	01.15.52
<b>0.00</b>		V	T42
<b>0.08</b>		27	01.16.04
		V	T43
<b>0.48</b>		27	01.16.57
		V	T43
<b>0.63</b>		27	01.17.17
		V	T43
<b>0.84</b>		27	01.17.45
		V	T43
<b>1.00</b>		27	01.18.06
		V	T43
<b>1.27</b>		27	01.18.42
		V	T43
<b>1.56</b>		27	01.19.21
		V	T43
<b>1.81</b>		18	01.19.54
		V	T44

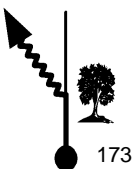
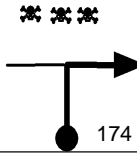

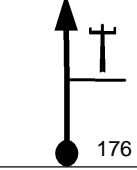
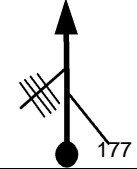
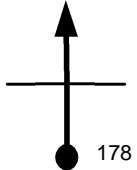
04 DE NOVEMBRO DE 2017		Pág: 015	
<b>2.31</b>		18	01.21.34
		V	T44
<b>2.38</b>		18	01.21.48
		V	T44
<b>2.47</b>		18	01.22.06
		V	T44
<b>2.70</b>		27	01.22.52
		V	T45
<b>3.16</b>		27	01.23.54
		V	T45
<b>3.19</b>		27	01.23.58
		V	T45
<b>3.95</b>		24	01.25.39
		V	T46
<b>4.00</b>		15	01.25.46
		V	T47
<b>4.20</b>		30	01.26.34
		V	T48
APOIO			
RETORNE			
<b>4.82</b>		16'	01.27.49
<b>0.00</b>		N	T49

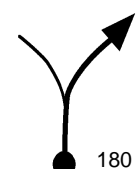
04 DE NOVEMBRO DE 2017		Pág: 016	
<b>0.00</b>		39	01.43.49
		V	T50
<b>0.00</b>		39	01.43.49
		V	T50
CUIDADO			
MOTOS			
SAINDO			
<b>0.63</b>		39	01.44.47
		V	T50
<b>0.80</b>		39	01.45.03
		V	T50
<b>1.04</b>		39	01.45.25
		V	T50
<b>1.11</b>		39	01.45.31
		V	T50
EUCALIPTO			
COM BAMP			
<b>1.86</b>		39	01.46.40
		V	T50
<b>2.20</b>		39	01.47.12
		V	T50
<b>2.23</b>		39	01.47.15
		V	T50

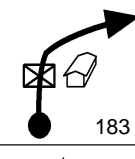
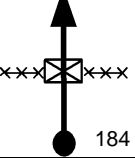
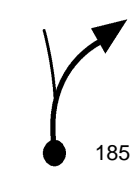
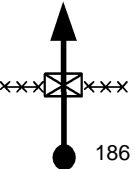
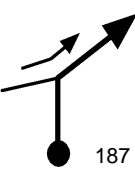
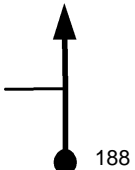
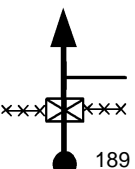
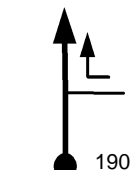

04 DE NOVEMBRO DE 2017		Pág: 017	
<b>2.45</b>		39	01.47.35
		V	T50
<b>2.92</b>		39	01.48.18
		V	T50
<b>3.57</b>		27	01.49.18
		V	T51
<b>4.63</b>		27	01.51.40
		V	T51
<b>4.74</b>		27	01.51.54
		V	T51
<b>4.89</b>		27	01.52.14
		V	T51
<b>5.90</b>		12	01.54.29
		V	T52
<b>5.91</b>		12	01.54.32
		V	T52
<b>5.92</b>		27	01.54.35
		V	T53
<b>5.99</b>		27	01.54.44
		V	T53
SIGA			
BAMPS			

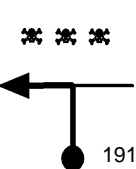

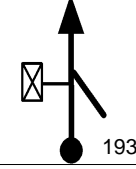
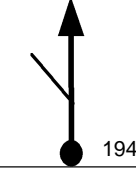
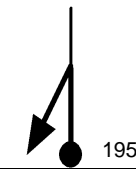
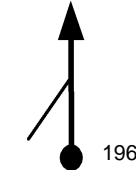
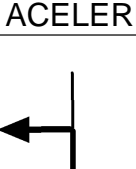
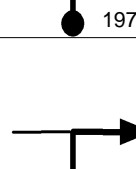
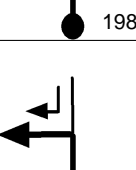
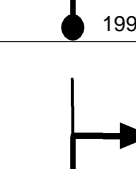

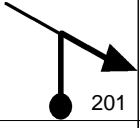
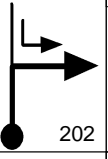
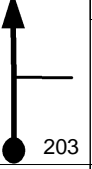
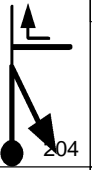
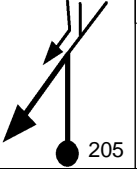
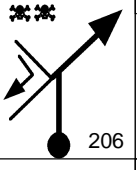
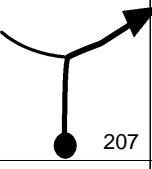
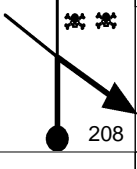
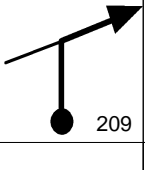
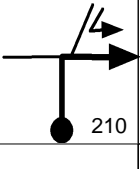
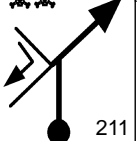
04 DE NOVEMBRO DE 2017		Pág: 018	
<b>6.03</b>		27	01.54.50
		V	T53
<b>6.18</b>		2'	01.55.10
		N	T54
<b>6.18</b>		45	01.57.10
		V	T55
<b>6.90</b>		39	01.58.07
		V	T56
<b>7.13</b>		39	01.58.28
		V	T56
<b>7.81</b>		30	01.59.31
		V	T57
CUIDADO			
PONTE			
ESTREITA			
<b>8.11</b>		30	02.00.07
		V	T57
			
<b>8.16</b>		30	02.00.13
		V	T57

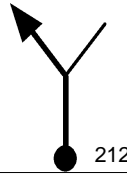
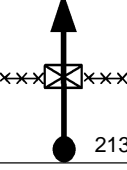
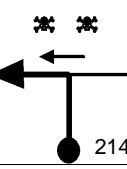
04 DE NOVEMBRO DE 2017		Pág: 019	
<b>8.45</b>		1'	02.00.48
		N	T58
DEVAGAR			
PERIGO			
<b>8.45</b>		9	02.01.48
		V	T59
SIGA			
OS BAMPS			
<b>8.60</b>		9	02.02.48
		V	T59
<b>8.68</b>		15	02.03.20
		V	T60
<b>8.86</b>		15	02.04.03
		V	T60
		27	02.04.39
<b>9.01</b>		V	T61
		27	02.04.49
<b>9.08</b>		V	T61
		27	02.04.53
<b>9.11</b>		V	T61
		27	02.04.59
<b>9.16</b>		V	T61
		27	02.05.30
<b>9.39</b>		V	T61

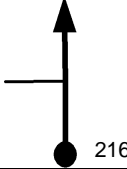
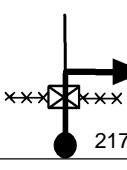
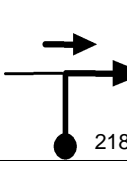
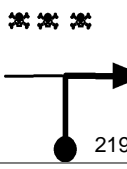
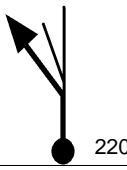
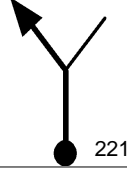
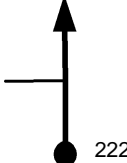
04 DE NOVEMBRO DE 2017		Pág: 020	
<b>9.43</b>		1'	02.05.35
<b>0.00</b>		N	T62
<b>0.00</b>		36	02.06.35
		V	T63
<b>0.54</b>		36	02.07.29
		V	T63
<b>0.58</b>		27	02.07.33
		V	T63
<b>0.90</b>		27	02.08.05
		V	T64
<b>1.42</b>		27	02.09.15
		V	T64
ACELERE			
<b>1.83</b>		27	02.10.09
		V	T64
		24	02.10.59
<b>2.20</b>		V	T65
		24	02.11.02
<b>2.22</b>		V	T65
		24	02.11.14
<b>2.30</b>		V	T65

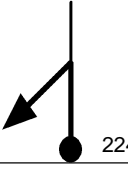
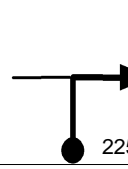
04 DE NOVEMBRO DE 2017		Pág: 021	
<b>2.44</b>		24	02.11.35
		V	T65
<b>2.61</b>		24	02.12.00
		V	T65
<b>2.68</b>		24	02.12.11
		V	T65
<b>2.75</b>		24	02.12.21
		V	T65
<b>2.94</b>		24	02.12.50
		V	T65
<b>3.14</b>		24	02.13.20
		V	T65
<b>3.15</b>		24	02.13.21
		V	T65
<b>3.45</b>		12	02.14.06
		V	T66
<b>3.49</b>		12	02.14.18
		V	T66
<b>3.58</b>		24	02.14.45
		V	T67
<b>3.76</b>		24	02.15.12
		V	T67

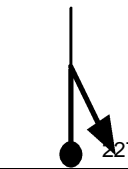
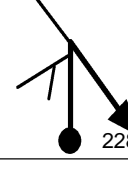
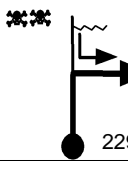
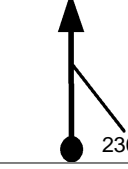
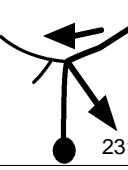
04 DE NOVEMBRO DE 2017		Pág: 022	
<b>3.77</b>		24	02.15.14
		V	T67
<b>3.89</b>		24	02.15.32
		V	T67
<b>4.05</b>		1'	02.15.56
		N	T68
<b>4.05</b>		24	02.16.56
		V	T69
<b>4.08</b>		24	02.17.00
		V	T69
<b>4.14</b>		24	02.17.09
		V	T69
<b>4.49</b>		24	02.18.02
		V	T69
<b>4.53</b>		39	02.18.08
		V	T70
<b>4.78</b>		30	02.18.31
		V	T71
<b>4.81</b>		30	02.18.34
		V	T71
<b>4.90</b>		30	02.18.45
		V	T71

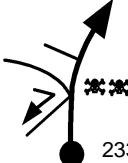
04 DE NOVEMBRO DE 2017		Pág: 023	
<b>4.99</b>		30	02.18.56
		V	T71
<b>5.21</b>		24	02.19.22
		V	T72
<b>5.39</b>		24	02.19.49
		V	T72
<b>5.58</b>		21	02.20.18
		V	T73
<b>5.68</b>		21	02.20.35
		V	T73
<b>5.83</b>		21	02.21.01
		V	T73
<b>5.92</b>		21	02.21.16
		V	T73
<b>6.02</b>		21	02.21.33
		V	T73
<b>6.12</b>		21	02.21.50
		V	T73
<b>6.29</b>		21	02.22.19
		V	T73
<b>6.50</b>		30	02.22.55
		V	T74



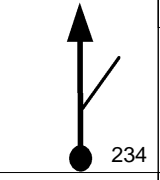
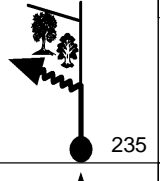
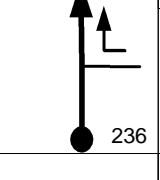
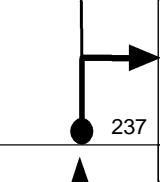
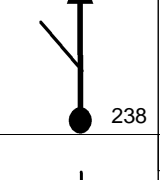
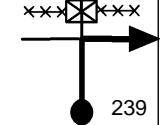



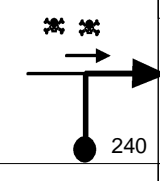
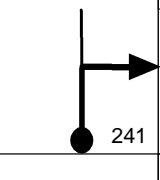
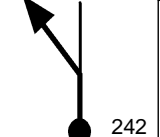

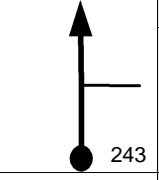
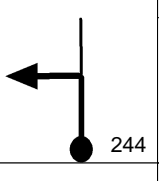
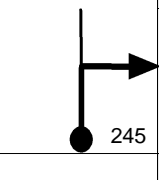
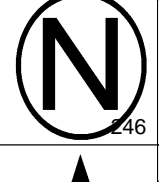
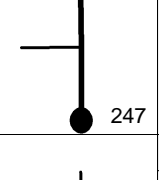
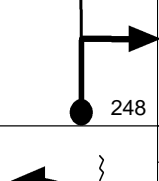
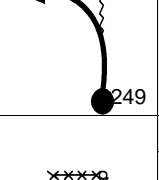
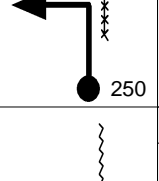
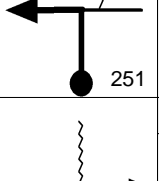
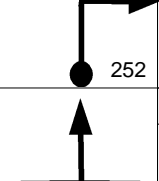
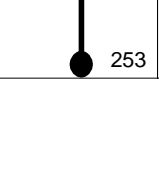

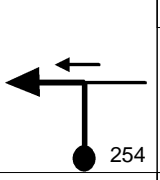
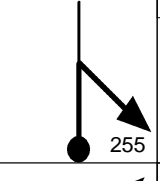
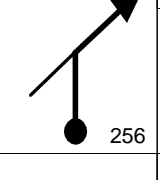
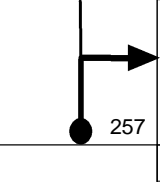
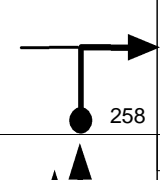
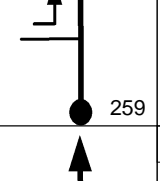
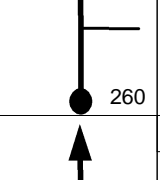
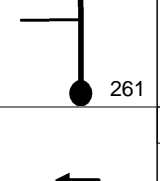
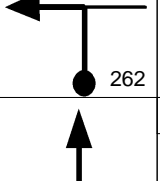
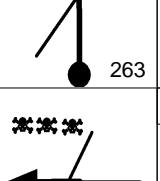
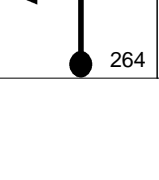
<b>6.66</b>		30	02.23.15
		V	T74
<b>7.07</b>		15	02.24.04
		V	T75
<b>7.13</b>		30	02.24.18
		V	T76
<b>7.22</b>		30	02.24.29
		V	T76
<b>7.25</b>		30	02.24.33
		V	T76
<b>7.38</b>		30	02.24.48
		V	T76



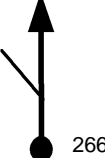

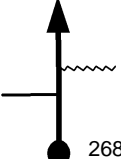

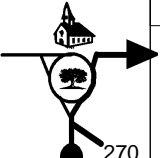

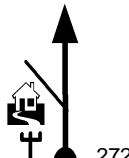
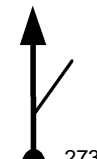
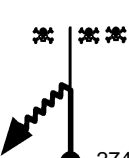

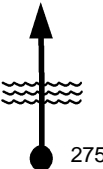
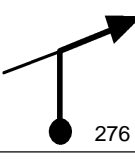
<b>7.53</b>		30	02.25.06
		V	T76
<b>7.63</b>		30	02.25.18
		V	T76
<b>7.66</b>		24	02.25.22
		V	T77

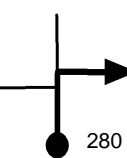
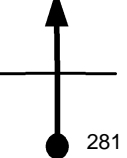
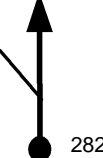
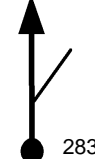
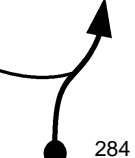
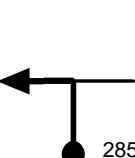

<b>7.76</b>		24	02.25.37
		V	T77
<b>7.78</b>		24	02.25.40
		V	T77
<b>7.88</b>		1'	02.25.55
		N	T78
<b>7.88</b>		30	02.26.55
		V	T79
<b>8.19</b>		30	02.27.32
		V	T79
<b>8.30</b>		27	02.27.45
		V	T80
<b>8.48</b>		27	02.28.09
		V	T80
<b>8.64</b>		27	02.28.31
		V	T80
<b>8.71</b>		27	02.28.40
		V	T80
<b>8.76</b>		27	02.28.47
		V	T80
<b>8.82</b>		27	02.28.55
		V	T80

<b>9.22</b>		27	02.29.48
		V	T80
<b>9.24</b>		27	02.29.51
		V	T80
<b>9.34</b>		27	02.30.04
		V	T80
<b>9.39</b>		27	02.30.11
		V	T80
<b>9.47</b>		21	02.30.21
		V	T81
<b>9.56</b>		27	02.30.37
		V	T82
<b>9.58</b>		27	02.30.39
		V	T82
<b>9.65</b>		27	02.30.49
		V	T82
<b>9.67</b>		27	02.30.51
		V	T82
<b>9.89</b>		27	02.31.21
		V	T82
<b>10.02</b>		1'	02.31.38
<b>0.00</b>		N	T83

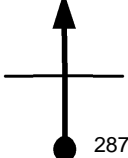
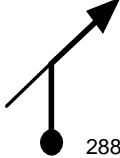
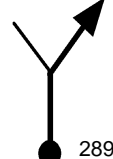
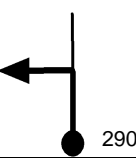
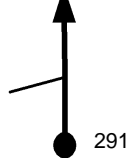
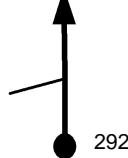
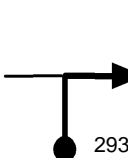
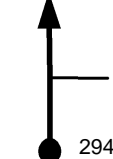
04 DE NOVEMBRO DE 2017		Pág: 027	
0.00		36	02.32.38
		V	T84
0.14		36	02.32.52
		V	T84
0.22		36	02.33.00
		V	T84
0.40		36	02.33.18
		V	T84
0.52		36	02.33.30
		V	T84
0.73		36	02.33.51
		V	T84
1.07		36	02.34.25
		V	T84
1.59		24	02.35.17
		V	T85
2.13		12	02.36.38
		V	T86
CUIDADO			
DESCIDA PERIGOSA			
2.14		12	02.36.41
		V	T86

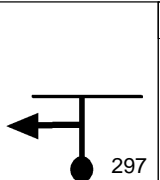
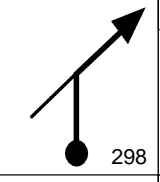
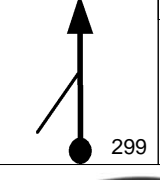

04 DE NOVEMBRO DE 2017		Pág: 028	
2.27		9	02.37.20
		V	T87
2.57		1'30s	02.39.20
		N	T88
2.57		30	02.40.50
		V	T89
2.86		30	02.41.25
		V	T89
2.96		30	02.41.37
		V	T89
3.09		27	02.41.52
		V	T90
3.33		27	02.42.24
		V	T90
3.37		27	02.42.30
		V	T90
3.40		27	02.42.34
		V	T90
3.80		27	02.43.27
		V	T90
3.96		27	02.43.48
		V	T90

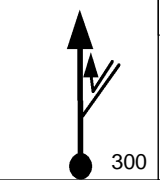
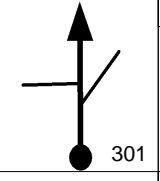
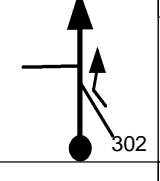
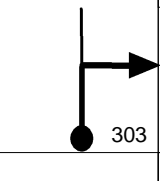
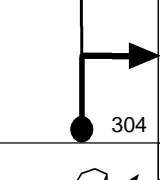
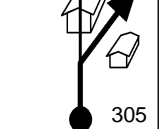

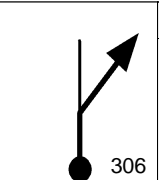
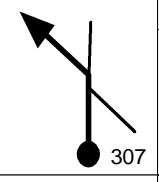
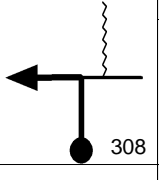
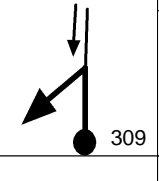
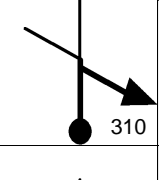
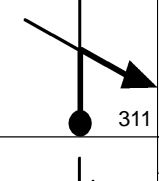
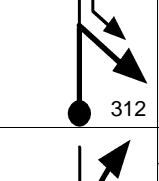
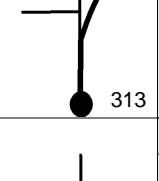
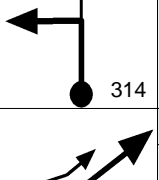
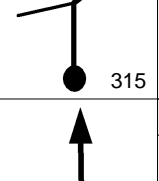
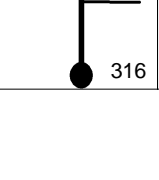
04 DE NOVEMBRO DE 2017		Pág: 029	
4.01		27	02.43.55
		V	T90
4.17		27	02.44.16
		V	T90
4.33		27	02.44.38
		V	T90
4.73		27	02.45.31
		V	T90
4.86		27	02.45.48
		V	T90
4.90		27	02.45.54
		V	T90
4.94		27	02.45.59
		V	T90
5.11		27	02.46.22
		V	T90
5.26		27	02.46.42
		V	T90
5.36		27	02.46.55
		V	T90
5.48		27	02.47.11
		V	T90

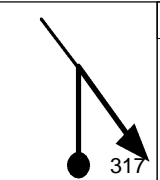
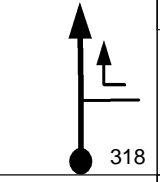
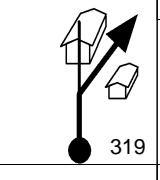
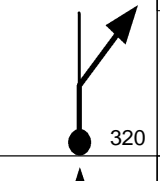
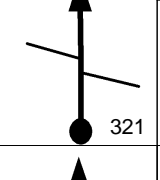
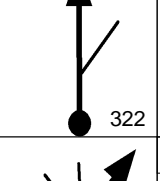
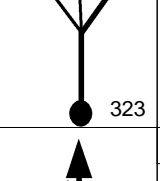
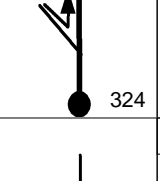
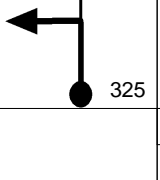
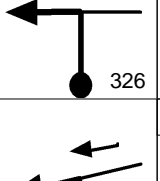
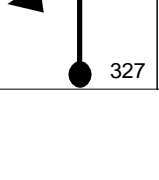

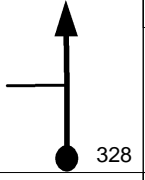
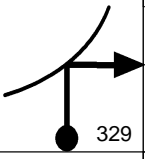

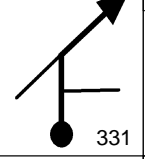
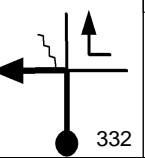
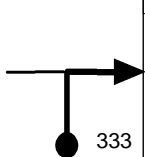
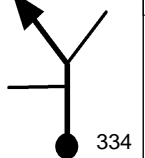
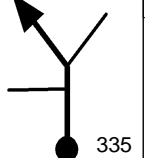
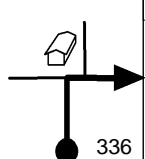
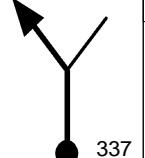
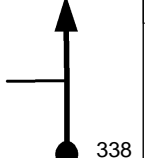

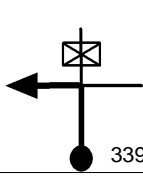
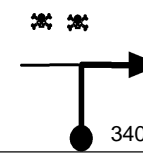
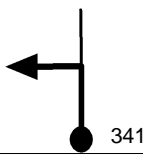
04 DE NOVEMBRO DE 2017		Pág: 030	
<b>5.52</b>		27	02.47.16
		V	T90
<b>5.67</b>		27	02.47.36
		V	T90
<b>6.03</b>		27	02.48.24
		V	T90
			
<b>6.18</b>		27	02.48.44
		V	T90
<b>6.40</b>		27	02.49.14
		V	T90
<b>6.51</b>		27	02.49.28
		V	T90
<b>6.60</b>		15	02.49.40
		V	T91
<b>6.61</b>		15	02.49.43
		V	T91
<b>6.65</b>		30	02.49.52
		V	T92

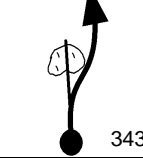
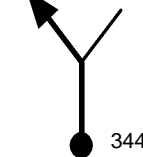
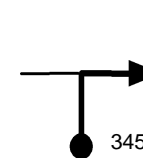
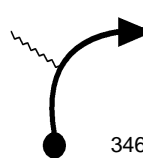
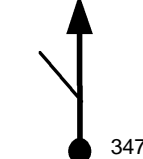
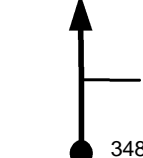
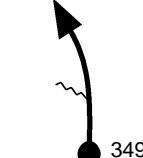
04 DE NOVEMBRO DE 2017		Pág: 031	
<b>7.02</b>		30	02.50.37
		V	T92
<b>7.11</b>		30	02.50.48
		V	T92
<b>7.30</b>		24	02.51.10
		V	T93
<b>7.53</b>		27	02.51.45
		V	T94
<b>7.62</b>		24	02.51.57
		V	T95
<b>8.41</b>		24	02.53.55
		V	T95
<b>8.48</b>		24	02.54.06
		V	T95
<b>8.69</b>		24	02.54.37
		V	T95
<b>8.77</b>		24	02.54.49
		V	T95
<b>8.83</b>		15	02.54.58
		V	T95
<b>8.91</b>		15	02.55.10
		V	T96

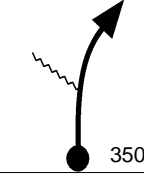
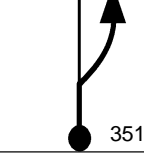
04 DE NOVEMBRO DE 2017		Pág: 032	
<b>8.92</b>		15	02.55.13
		V	T96
<b>8.94</b>		15	02.55.18
		V	T96
<b>8.98</b>		27	02.55.27
		V	T97
<b>9.34</b>		27	02.56.15
		V	T97
<b>9.44</b>		27	02.56.29
		V	T97
<b>9.74</b>		27	02.57.09
		V	T97
<b>9.80</b>		27	02.57.17
		V	T97
<b>10.01</b>		12	02.57.45
		V	T98
<b>10.02</b>		12	02.57.48
		V	T98
<b>10.03</b>		12	02.57.51
		V	T98
<b>10.04</b>		12	02.57.54
		V	T98

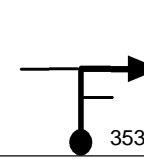
04 DE NOVEMBRO DE 2017		Pág: 033	
10.05		27	02.57.57
		V	T99
10.31		1'	02.58.31
0.00		N	T100
0.00		24	02.59.31
		V	T101
0.10		24	02.59.46
		V	T101
0.13		24	03.01.07
		V	T101
0.64		24	03.02.03
		V	T101
1.01		24	03.02.12
		V	T101
1.07		36	03.03.06
		V	T101
1.43		36	03.03.36
		V	T102
1.73		36	03.03.55
		V	T102
1.92			
		V	T102

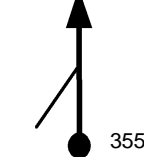
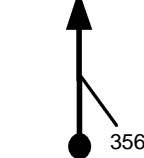
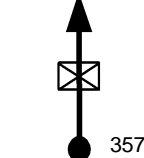
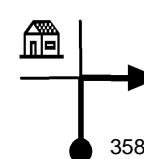
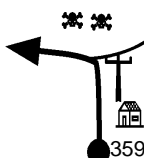
04 DE NOVEMBRO DE 2017		Pág: 034	
2.79		36	03.05.22
		V	T102
3.18		36	03.06.01
		V	T102
3.37		1'30s	03.06.20
0.00		N	T103
0.00		30	03.07.50
		V	T104
0.08		30	03.07.59
		V	T104
0.48		30	03.08.47
		V	T104
0.63		30	03.09.05
		V	T104
0.84		30	03.09.30
		V	T104
1.00		30	03.09.50
		V	T104
1.27		30	03.10.22
		V	T104
1.56		30	03.10.57
		V	T104

04 DE NOVEMBRO DE 2017		Pág: 035	
1.81		18	03.11.27
		V	T105
2.31		18	03.13.07
		V	T105
2.38		18	03.13.21
		V	T105
2.47		18	03.13.39
		V	T105
2.70		27	03.14.25
		V	T106
3.16		27	03.15.26
		V	T106
3.19		24	03.15.30
		V	T106
3.95		24	03.17.12
		V	T107
4.00		15	03.17.19
		V	T108
4.20		30	03.18.07
		V	T109
			

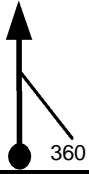
**4.82****0.00****30** 03.19.21**V****T110****FIM DE PROVA !!**[www.t15.com.br](http://www.t15.com.br)

PARABÉNS VOCÊ CONSEGUIU, ATÉ  
2018.

A DIRETORIA DO MTC AGRADECE A  
PARTICIPAÇÃO DE TODOS OS  
PILOTOS PELA PARTICIPAÇÃO NO  
CAMPEONATO, E DESDE JÁ  
CONVIDA A TODOS PARA  
PARTICIPAR DA FESTA DE  
ENCERRAMENTO E ENTREGA DA  
PREMIAÇÃO DAS COPAS DE ENDURO  
DE REGULARIDADE E ENDURO FIM  
QUE SERÁ NO DIA 25/11/2017

**Tempo de Prova**

MÉDIA C 03:19:21

**FIM**