

INICIO

MÉDIA B

1º ENDURO DAS CACHOEIRAS
04 DE NOVEMBRO DE 2017



IMPORTANTE

O PILOTO QUE ANDAR SEM
CAPACETE ANTES DA PROVA SERA
PENALIZADO COM A
DESCLASSIFICAÇÃO.
RESPEITE AS ROÇAS PARA TERMOS
TRILHAS.

CUIDADO

ATENÇÃO

MUITA ATENÇÃO

Tempo de Prova

MÉDIA B 03:17:08



AFERIÇÃO

INICIO AFERIÇÃO

0.00		1	AFER
0.63		2	AFER
0.80		3	AFER

1.04		4	AFER
1.11		5	AFER
EUCALIPTO COM BAMP			
1.86		6	AFER
2.20		7	AFER
2.23		8	AFER

FIM DA AFERIÇÃO

VOLTE AO INICIO

COM CUIDADO

2.45		9	AFER
0.00			



INÍCIO DE PROVA

0.00		10	V	T1
42 00.00.00				

CUIDADO MOTOS

1.33		11	V	T2	33 00.01.54
1.37		12	V	T2	33 00.01.58
1.39		13	V	T2	33 00.02.01
3.09		14	V	T2	33 00.05.06
3.15		15	V	T2	33 00.05.13
3.66		16	V	T2	33 00.06.08
3.74		17	V	T3	30 00.06.17
3.96		18	V	T3	30 00.06.43
4.22		19	V	T4	21 00.07.14
4.26		20	V	T4	21 00.07.21
4.48		21	V	T5	30 00.07.59

04 DE NOVEMBRO DE 2017		Pág: 003	
4.75		30	00.08.31
		V	T5
4.87		30	00.08.46
		V	T5
4.90		30	00.08.49
		V	T5
4.99		27	00.09.00
		V	T6
CUIDADO MOTOS			
5.07		27	00.09.11
		V	T6
5.10		27	00.09.15
		V	T6
5.19		27	00.09.27
		V	T6
5.28		27	00.09.39
		V	T6
5.53		27	00.10.12
		V	T6
CUIDADO DESCIDA LISA			
5.56		18	00.10.16
		V	T7

04 DE NOVEMBRO DE 2017		Pág: 004	
5.64		18	00.10.32
		V	T7
5.72		18	00.10.48
		V	T7
5.85		15	00.11.14
		V	T8
5.89		15	00.11.24
		V	T8
5.99		2'30s	00.11.48
0.00		N	T9
		33	00.14.18
0.00		V	T10
		33	00.15.12
0.50		V	T10
		30	00.15.21
0.58		V	T11
		30	00.15.48
0.80		V	T11
		30	00.16.20
1.07		V	T11
		30	00.16.34
1.19		V	T11

04 DE NOVEMBRO DE 2017		Pág: 005	
1.22		30	00.16.38
		V	T11
1.31		30	00.16.49
		V	T11
1.40		27	00.17.00
		V	T12
1.48		27	00.17.10
		V	T12
1.59		27	00.17.25
		V	T12
1.65		27	00.17.33
		V	T12
1.84		27	00.17.58
		V	T12
1.84		27	00.18.10
		V	T12
1.93		27	00.18.16
		V	T12
1.97		27	00.18.30
		V	T12
2.08		27	00.18.30
		V	T12
2.08		27	00.18.57
		V	T12
2.28		27	00.18.57
		V	T12

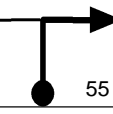
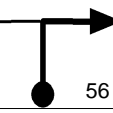
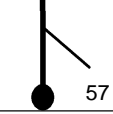
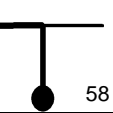
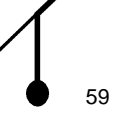

2.34		27	00.19.05
		V	T12
2.44		27	00.19.18
		V	T12
2.47		27	00.19.22
		V	T12
2.58		27	00.19.37
		V	T12
2.88		33	00.20.17
		V	T13
3.08		33	00.20.39
		V	T13





3.94		12	00.22.12
		V	T14
DEVAGAR			
RESPEITE AS CASAS			

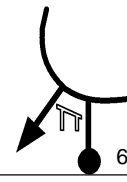
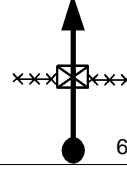
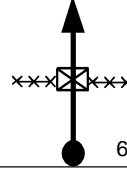
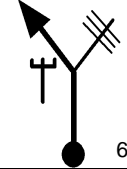
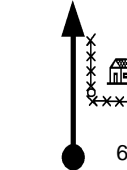
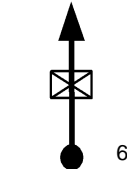
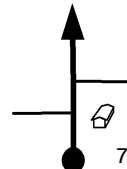
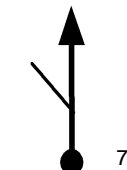

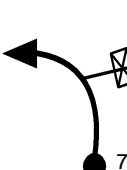
4.02		12	00.22.36
		V	T14

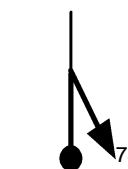
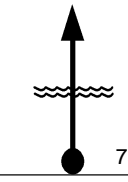
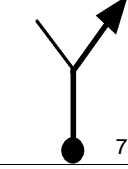
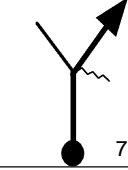
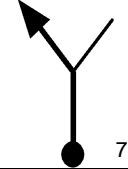
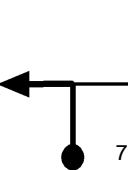
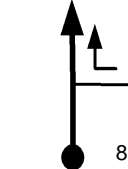
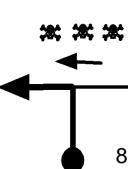
4.18		2'	00.23.24
		N	T15

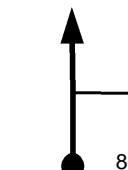

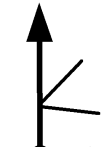
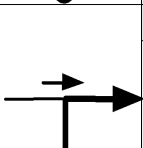
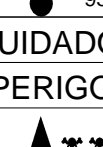
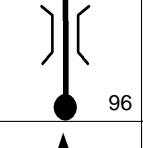
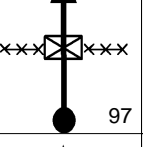
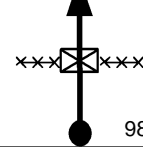
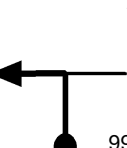

4.18		30	00.25.24
		V	T16
4.35		30	00.25.45
		V	T16
5.00		30	00.27.03
		V	T16
5.10		30	00.27.15
		V	T16
5.17		30	00.27.23
		V	T16
5.22		30	00.27.29
		V	T16
5.43		24	00.27.54
		V	T17
6.56		30	00.30.44
		V	T18
6.67		30	00.30.57
		V	T18
7.00		30	00.31.37
		V	T18
7.47		30	00.32.33
		V	T18

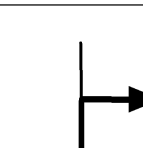
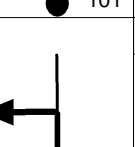

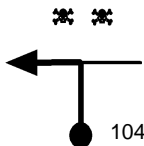
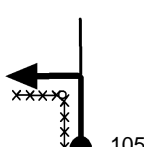
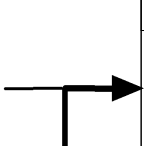
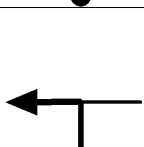
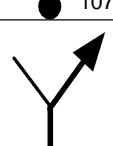
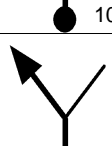
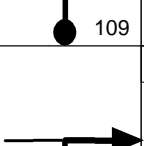
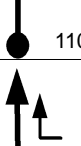
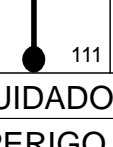
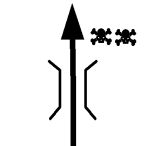
7.73		27	00.33.04
		V	T19
7.79		27	00.33.12
		V	T19
7.84		27	00.33.19
		V	T19
8.26		27	00.34.15
		V	T19
8.41		27	00.34.35
		V	T19
8.68		27	00.35.11
		V	T19
8.75		27	00.35.20
		V	T19
9.71		1'30s	00.37.28
0.00		N	T20
0.00		33	00.38.58
		V	T21
0.06		33	00.39.05
		V	T21
0.09		33	00.39.08
		V	T21

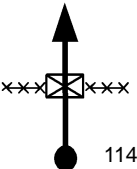
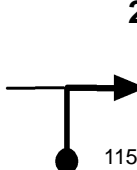
04 DE NOVEMBRO DE 2017		Pág: 009	
1.56		30	00.41.49
		V	T22
1.84		30	00.42.22
		V	T22
1.87		30	00.42.26
		V	T22
RESPEITE AS ROÇAS			
1.92		21	00.42.32
		V	T23
2.03		30	00.42.51
		V	T24
CUIDADO PERIGO			
ACERTAR ODOMETRO LARGAR DO NEUTRO COM 0,11			
2.37		2'30s	00.43.31
0.00		N	T25
0.00		36	00.46.01
		V	T26
0.65		30	00.47.06
		V	T27
1.72		30	00.49.15
		V	T27

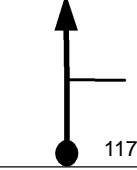
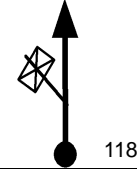
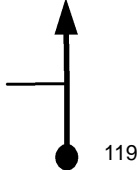

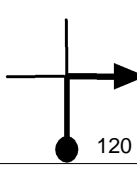
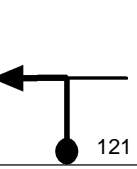
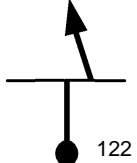

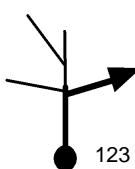
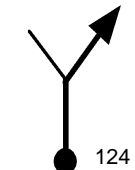
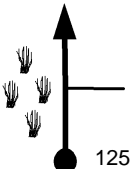
04 DE NOVEMBRO DE 2017		Pág: 010	
1.83		30	00.49.28
		V	T27
1.98		24	00.49.46
		V	T28
CUIDADO PERIGO			
2.33		27	00.50.39
		V	T29
2.80		27	00.51.41
		V	T29
2.92		27	00.51.57
		V	T29
		2'30s	00.52.09
3.01		N	T30
		30	00.54.39
3.01		V	T31
		30	00.55.46
3.57		V	T31
		30	00.55.54
3.63		V	T31
		30	00.56.02
3.70		V	T31

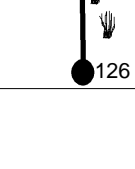
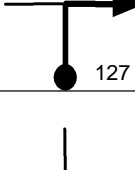
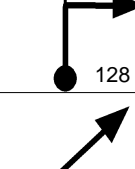
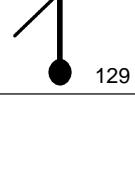
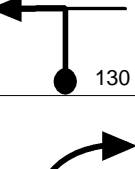
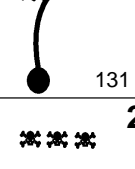

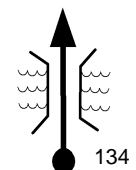
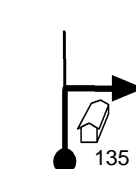
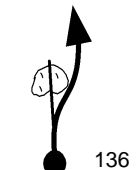
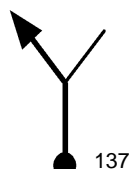
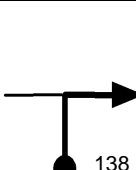
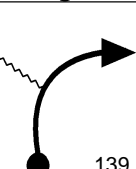
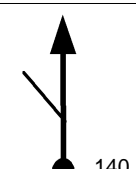
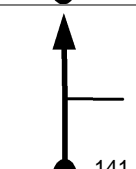
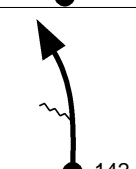
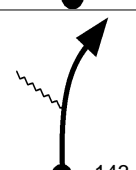

04 DE NOVEMBRO DE 2017		Pág: 011	
3.74		30	00.56.07
		V	T31
4.47		33	00.57.34
		V	T32
		33	00.57.51
4.62		V	T32
		27	00.57.55
4.66		V	T33
		27	00.58.04
4.73		V	T33
		27	00.58.06
4.74		V	T33
		27	00.58.07
4.75		V	T33
		24	01.00.23
5.77		V	T34
CUIDADO PERIGO			
6.12		27	01.01.16
		V	T35
6.59		27	01.02.18
		V	T35

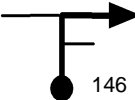
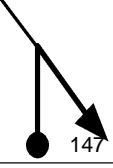
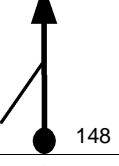

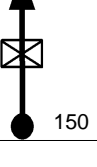
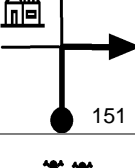
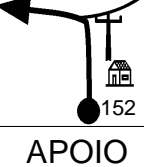
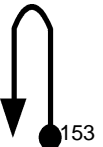

6.71		27 01.02.34	V T35
6.80		2'30s 01.02.46	N T36
6.80		33 01.05.16	V T37
6.86		33 01.05.23	V T37
7.05		33 01.05.44	V T37
8.00		33 01.07.27	V T37
			
8.03		24 01.07.30	V T38
8.07		24 01.07.36	V T38
8.12		24 01.07.44	V T38

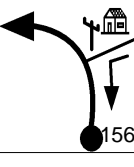
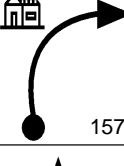
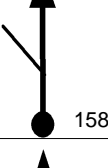
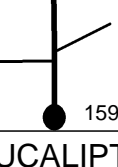

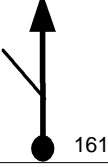
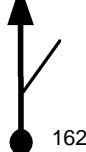

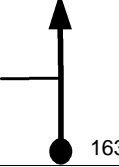
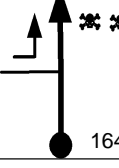
8.37		30 01.08.21	V T39
8.44		30 01.08.30	V T39
8.56		30 01.08.44	V T39
RESPEITE AS ROÇAS			
8.66		30 01.08.56	V T39
8.70		30 01.09.01	V T39
8.71		30 01.09.02	V T39
8.76		30 01.09.08	V T39
9.41		30 01.10.26	V T39
9.67		30 01.10.57	V T39
9.99		2'30s 01.11.36	N T40

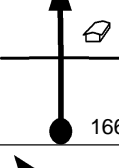
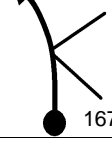
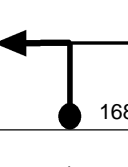
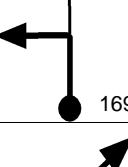
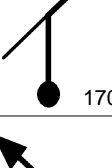

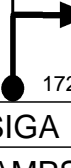
0.00		24 01.14.06	V T41
0.07		24 01.14.16	V T41
0.20 0.00		24 01.14.36	V T42
0.08		33 01.14.48	V T43
0.48		33 01.15.31	V T43
0.63		33 01.15.48	V T43
0.84		33 01.16.11	V T43
1.00		33 01.16.28	V T43
1.27		33 01.16.58	V T43
1.56		33 01.17.29	V T43
1.81		24 01.17.57	V T44

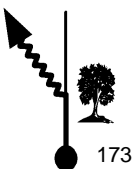
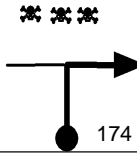

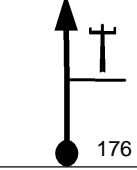
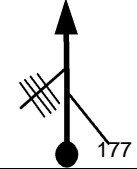
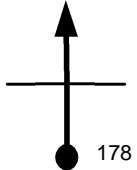
04 DE NOVEMBRO DE 2017		Pág: 015	
2.31		24	01.19.12
		V	T44
2.38		24	01.19.22
		V	T44
2.47		24	01.19.36
		V	T44
2.70		33	01.20.10
		V	T45
3.16		33	01.21.00
		V	T45
3.19		33	01.21.04
		V	T45
3.95		24	01.22.26
		V	T46
4.00		15	01.22.34
		V	T47
4.20		30	01.23.22
		V	T48
APOIO			
RETORNE			
4.82		19'	01.24.36
0.00		N	T49

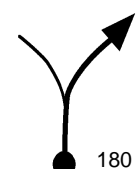
04 DE NOVEMBRO DE 2017		Pág: 016	
0.00		39	01.43.36
		V	T50
0.00		39	01.43.36
		V	T50
CUIDADO			
MOTOS			
SAINDO			
0.63		39	01.44.34
		V	T50
0.80		39	01.44.50
		V	T50
1.04		39	01.45.12
		V	T50
1.11		39	01.45.19
		V	T50
EUCALIPTO			
COM BAMP			
1.86		39	01.46.28
		V	T50
2.20		39	01.46.59
		V	T50
2.23		39	01.47.02
		V	T50

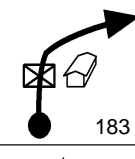
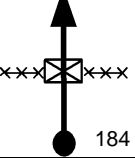
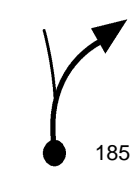
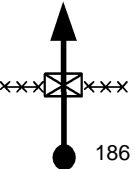
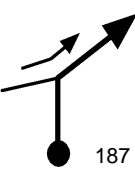
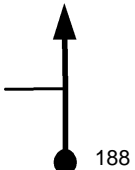
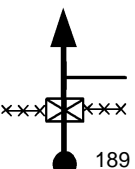
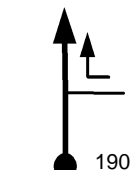

04 DE NOVEMBRO DE 2017		Pág: 017	
2.45		39	01.47.22
		V	T50
2.92		39	01.48.06
		V	T50
3.57		33	01.49.06
		V	T51
4.63		33	01.51.01
		V	T51
4.74		33	01.51.13
		V	T51
4.89		33	01.51.30
		V	T51
5.90		15	01.53.20
		V	T52
5.91		15	01.53.22
		V	T52
5.92		33	01.53.25
		V	T53
5.99		33	01.53.32
		V	T53
SIGA			
BAMPS			

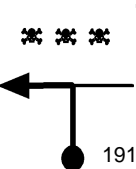

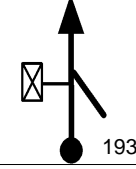
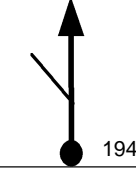
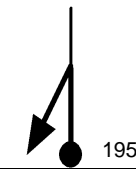
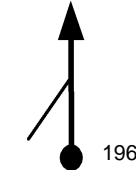
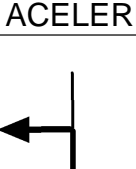
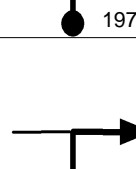
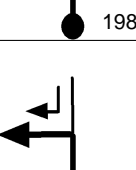
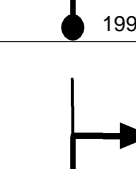

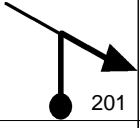
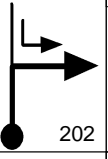
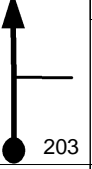
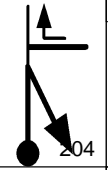
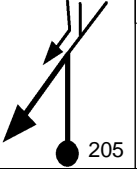
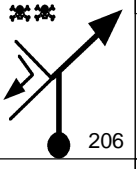
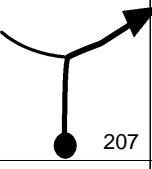
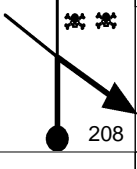
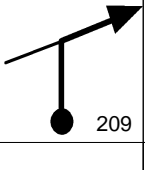
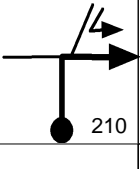
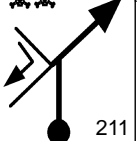
04 DE NOVEMBRO DE 2017		Pág: 018	
6.03		33	01.53.37
		V	T53
6.18		2'	01.53.53
		N	T54
6.18		45	01.55.53
		V	T55
6.90		39	01.56.51
		V	T56
7.13		39	01.57.12
		V	T56
7.81		33	01.58.15
		V	T57
CUIDADO			
PONTE			
ESTREITA			
8.11		33	01.58.48
		V	T57
			
8.16		33	01.58.53
		V	T57

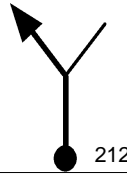
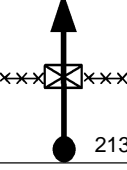
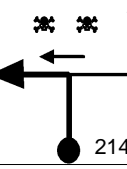
04 DE NOVEMBRO DE 2017		Pág: 019	
8.45		1'	01.59.25
		N	T58
DEVAGAR			
PERIGO			
8.45		9	02.00.25
		V	T59
SIGA			
OS BAMPS			
8.60		9	02.01.25
		V	T59
8.68		21	02.01.57
		V	T60
8.86		21	02.02.27
		V	T60
		30	02.02.53
9.01		V	T61
		30	02.03.02
9.08		V	T61
		30	02.03.05
9.11		V	T61
		30	02.03.11
9.16		V	T61
		30	02.03.39
9.39		V	T61

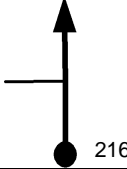
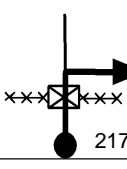
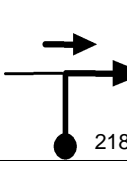
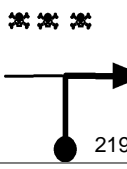
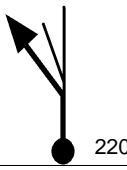
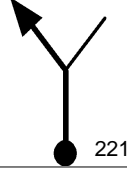
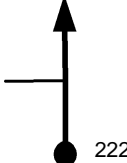
04 DE NOVEMBRO DE 2017		Pág: 020	
9.43		1'30s	02.03.44
0.00		N	T62
0.00		36	02.05.14
		V	T63
0.54		36	02.06.08
		V	T63
0.58		36	02.06.12
		V	T63
0.90		33	02.06.44
		V	T64
1.42		33	02.07.40
		V	T64
ACELERE			
1.83		33	02.08.25
		V	T64
		30	02.09.05
2.20		V	T65
		30	02.09.08
2.22		V	T65
		30	02.09.17
2.30		V	T65

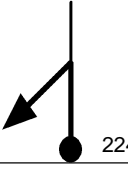
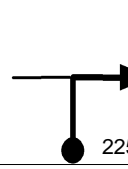
04 DE NOVEMBRO DE 2017		Pág: 021	
2.44		30	02.09.34
		V	T65
2.61		30	02.09.55
		V	T65
2.68		30	02.10.03
		V	T65
2.75		30	02.10.11
		V	T65
2.94		30	02.10.34
		V	T65
3.14		30	02.10.58
		V	T65
3.15		30	02.10.59
		V	T65
3.45		15	02.11.35
		V	T66
3.49		15	02.11.45
		V	T66
3.58		30	02.12.07
		V	T67
3.76		30	02.12.28
		V	T67

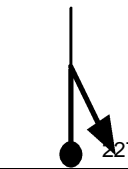
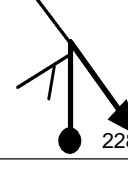
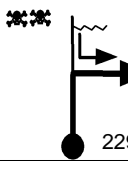
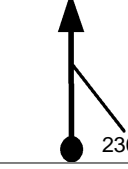
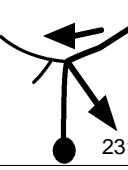
04 DE NOVEMBRO DE 2017		Pág: 022	
3.77		30	02.12.29
		V	T67
3.89		30	02.12.44
		V	T67
4.05		2'30s	02.13.03
		N	T68
4.05		30	02.15.33
		V	T69
4.08		30	02.15.37
		V	T69
4.14		30	02.15.44
		V	T69
4.49		30	02.16.26
		V	T69
4.53		39	02.16.31
		V	T70
4.78		33	02.16.54
		V	T71
4.81		33	02.16.57
		V	T71
4.90		33	02.17.07
		V	T71

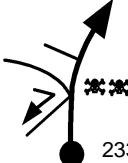
04 DE NOVEMBRO DE 2017		Pág: 023	
4.99		33	02.17.17
		V	T71
5.21		30	02.17.41
		V	T72
5.39		30	02.18.02
		V	T72
5.58		24	02.18.25
		V	T73
5.68		24	02.18.40
		V	T73
5.83		24	02.19.02
		V	T73
5.92		24	02.19.16
		V	T73
6.02		24	02.19.31
		V	T73
6.12		24	02.19.46
		V	T73
6.29		24	02.20.11
		V	T73
6.50		36	02.20.43
		V	T74

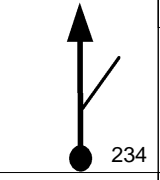
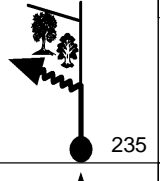
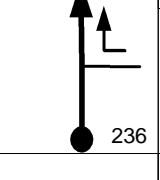
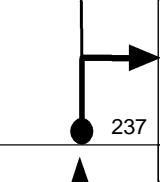
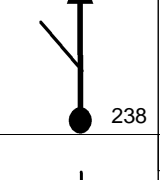
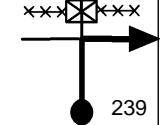

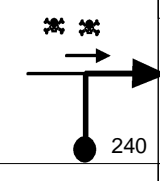
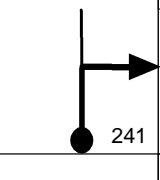
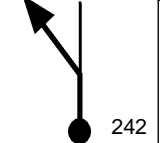

6.66		36	02.20.59
		V	T74
7.07		21	02.21.40
		V	T75
7.13		36	02.21.50
		V	T76
7.22		36	02.21.59
		V	T76
7.25		36	02.22.02
		V	T76
7.38		36	02.22.15
		V	T76

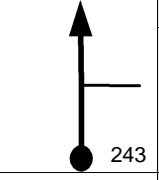
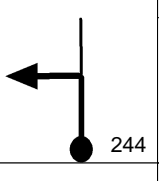
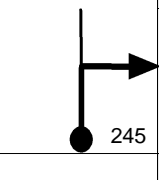
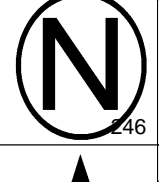
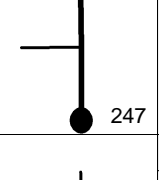
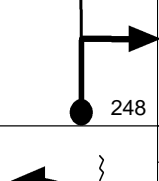
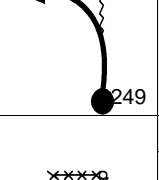
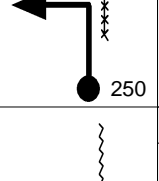
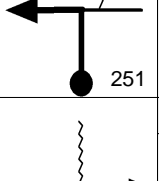
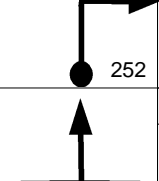
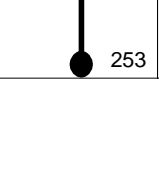

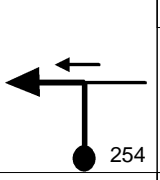
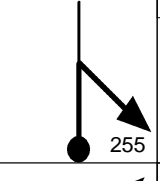
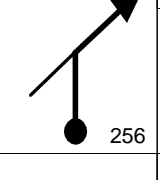
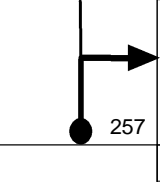
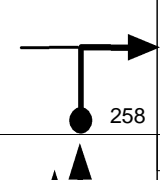
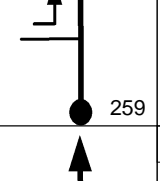
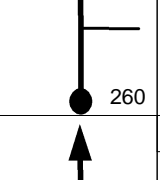
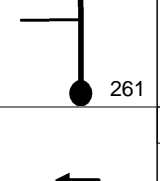
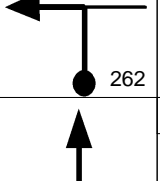
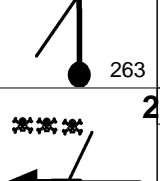
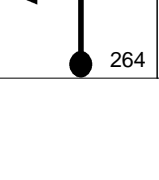

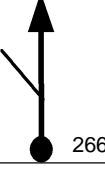
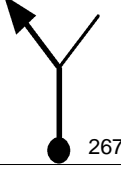
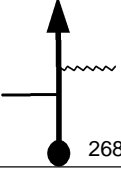

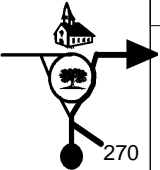
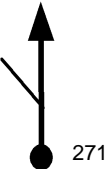
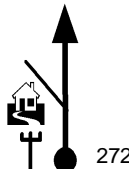

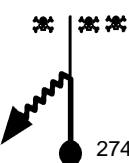

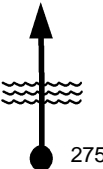
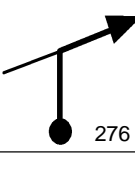

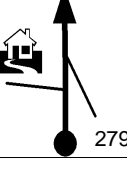
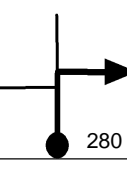
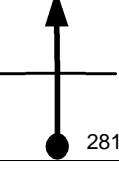
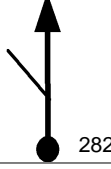
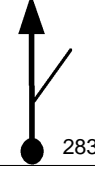
7.53		36	02.22.30
		V	T76
7.63		36	02.22.40
		V	T76
7.66		30	02.22.43
		V	T77

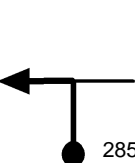

7.76		30	02.22.55
		V	T77
7.78		30	02.22.58
		V	T77
7.88		2'	02.23.10
		N	T78
7.88		36	02.25.10
		V	T79
8.19		36	02.25.41
		V	T79
8.30		33	02.25.52
		V	T80
8.48		33	02.26.11
		V	T80
8.64		33	02.26.29
		V	T80
8.71		33	02.26.36
		V	T80
8.76		33	02.26.42
		V	T80
8.82		33	02.26.48
		V	T80

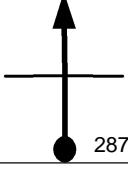
9.22		33	02.27.32
		V	T80
9.24		33	02.27.34
		V	T80
9.34		33	02.27.45
		V	T80
9.39		33	02.27.51
		V	T80
9.47		24	02.27.59
		V	T81
9.56		33	02.28.13
		V	T82
9.58		33	02.28.15
		V	T82
9.65		33	02.28.23
		V	T82
9.67		33	02.28.25
		V	T82
9.89		33	02.28.49
		V	T82
10.02		2'30s	02.29.03
0.00		N	T83

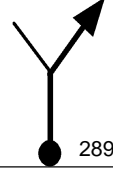
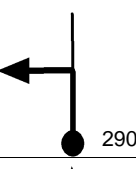
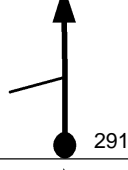
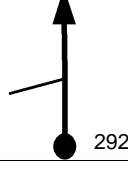
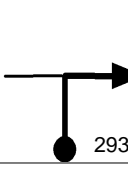
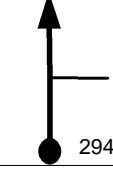
04 DE NOVEMBRO DE 2017		Pág: 027	
0.00		30	02.31.33
		V	T84
0.14		30	02.31.50
		V	T84
0.22		30	02.31.59
		V	T84
0.40		30	02.32.21
		V	T84
0.52		30	02.32.35
		V	T84
0.73		30	02.33.01
		V	T84
1.07		30	02.33.41
		V	T84
1.59		27	02.34.44
		V	T85
2.13		15	02.35.56
		V	T86
CUIDADO			
DESCIDA PERIGOSA			
2.14		15	02.35.58
		V	T86

04 DE NOVEMBRO DE 2017		Pág: 028	
2.27		12	02.36.29
		V	T87
2.57		2'30s	02.37.59
		N	T88
2.57		30	02.40.29
		V	T89
2.86		30	02.41.04
		V	T89
2.96		30	02.41.16
		V	T89
3.09		33	02.41.32
		V	T90
3.33		33	02.41.58
		V	T90
3.37		33	02.42.02
		V	T90
3.40		33	02.42.06
		V	T90
3.80		33	02.42.49
		V	T90
3.96		33	02.43.07
		V	T90

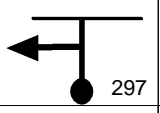
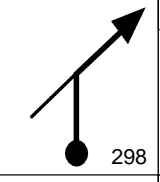
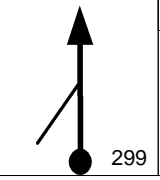

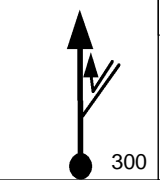
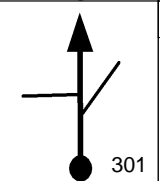
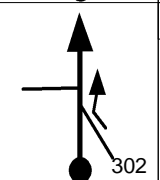
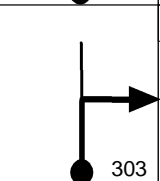
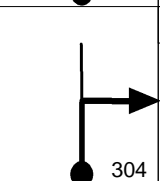
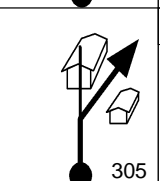
04 DE NOVEMBRO DE 2017		Pág: 029	
4.01		33	02.43.12
		V	T90
4.17		33	02.43.30
		V	T90
4.33		33	02.43.47
		V	T90
4.73		33	02.44.31
		V	T90
4.86		33	02.44.45
		V	T90
4.90		33	02.44.49
		V	T90
4.94		33	02.44.54
		V	T90
5.11		33	02.45.12
		V	T90
5.26		33	02.45.28
		V	T90
5.36		33	02.45.39
		V	T90
5.48		33	02.45.52
		V	T90

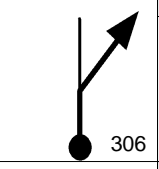
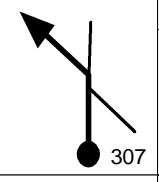
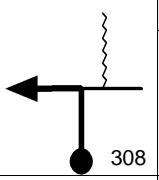
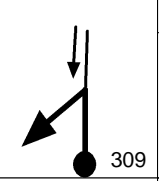
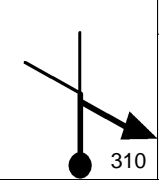
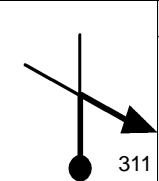
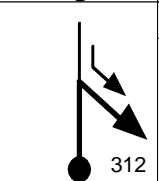
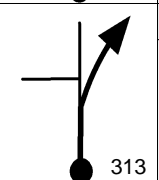
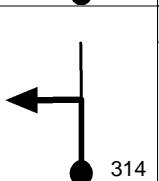
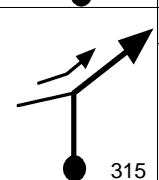
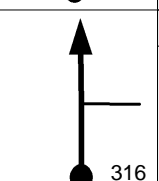

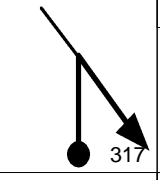
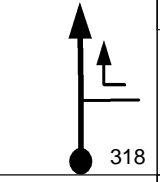
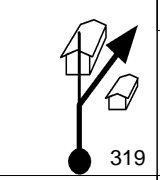
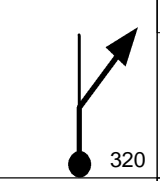
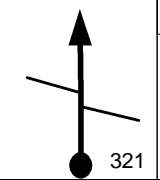
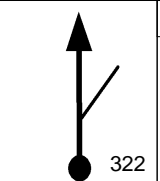
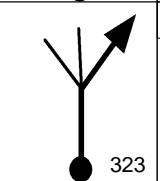
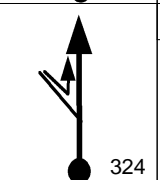
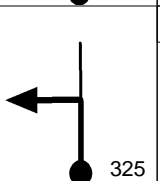
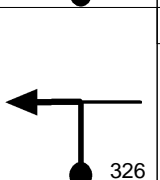
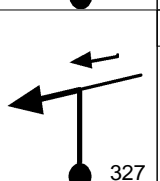
04 DE NOVEMBRO DE 2017		Pág: 030	
5.52		33	02.45.57
		V	T90
5.67		33	02.46.13
		V	T90
6.03		33	02.46.52
		V	T90
			
6.18		33	02.47.09
		V	T90
6.40		33	02.47.33
		V	T90
6.51		33	02.47.45
		V	T90
6.60		18	02.47.55
		V	T91
6.61		18	02.47.57
		V	T91
6.65		33	02.48.05
		V	T92

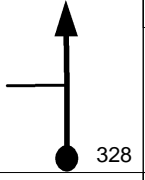
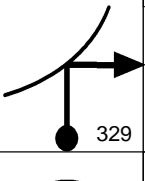
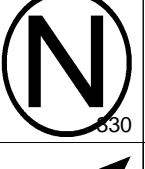
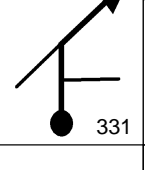
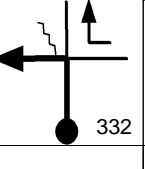
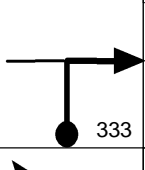
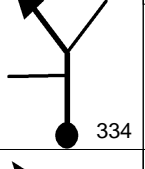
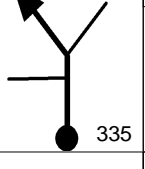
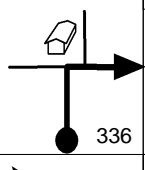
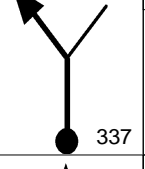
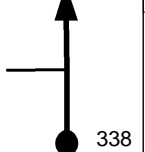
04 DE NOVEMBRO DE 2017		Pág: 031	
7.02		33	02.48.45
		V	T92
7.11		33	02.48.55
		V	T92
7.30		27	02.49.16
		V	T93
7.53		33	02.49.46
		V	T94
7.62		30	02.49.56
		V	T95
8.41		30	02.51.31
		V	T95
8.48		30	02.51.39
		V	T95
8.69		30	02.52.04
		V	T95
8.77		30	02.52.14
		V	T95
8.83		30	02.52.21
		V	T95
8.91		18	02.52.31
		V	T96

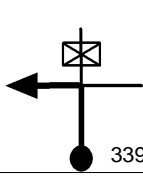
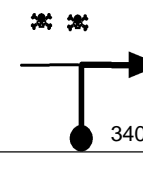
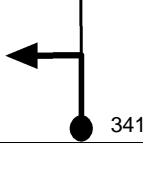
04 DE NOVEMBRO DE 2017		Pág: 032	
8.92		18	02.52.33
		V	T96
8.94		18	02.52.37
		V	T96
8.98		30	02.52.45
		V	T97
9.34		30	02.53.28
		V	T97
9.44		30	02.53.40
		V	T97
9.74		30	02.54.16
		V	T97
9.80		30	02.54.23
		V	T97
10.01		15	02.54.48
		V	T98
10.02		15	02.54.51
		V	T98
10.03		15	02.54.53
		V	T98
10.04		15	02.54.56
		V	T98

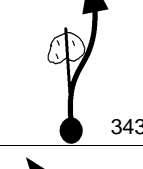
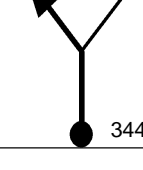
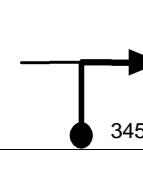
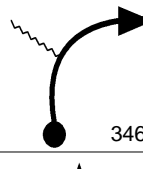
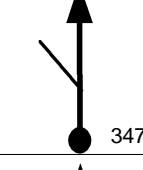
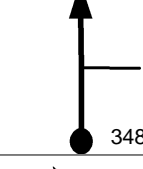
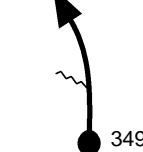
04 DE NOVEMBRO DE 2017		Pág: 033	
10.05		33	02.54.58
		V	T99
10.31		2'	02.55.26
0.00		N	T100
0.00		30	02.57.26
		V	T101
0.10		30	02.57.38
		V	T101
0.13		30	02.57.42
		V	T101
0.64		30	02.58.43
		V	T101
1.01		30	02.59.28
		V	T101
1.07		30	02.59.35
		V	T101
1.43		30	03.00.18
		V	T102
1.73		30	03.00.54
		V	T102
1.92		30	03.01.17
		V	T102

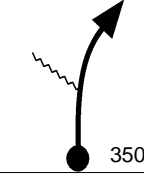
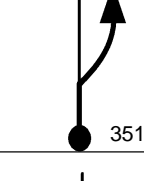
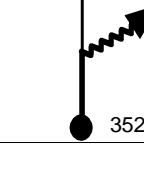
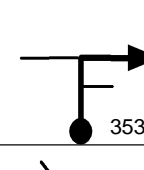
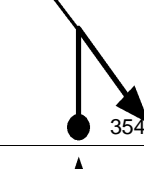
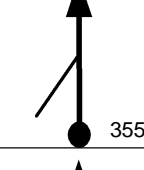
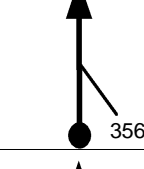
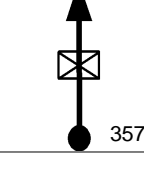
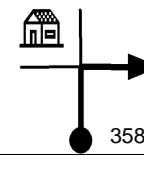
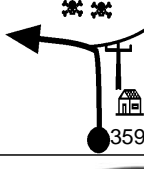
04 DE NOVEMBRO DE 2017		Pág: 034	
2.79		30	03.03.01
		V	T102
3.18		30	03.03.48
		V	T102
3.37		3'	03.04.11
0.00		N	T103
0.00		33	03.07.11
		V	T104
0.08		33	03.07.20
		V	T104
0.48		33	03.08.03
		V	T104
0.63		33	03.08.20
		V	T104
0.84		33	03.08.42
		V	T104
1.00		33	03.09.00
		V	T104
1.27		33	03.09.29
		V	T104
1.56		33	03.10.01
		V	T104

04 DE NOVEMBRO DE 2017		Pág: 035	
1.81		24	03.10.28
		V	T105
2.31		24	03.11.43
		V	T105
2.38		24	03.11.54
		V	T105
2.47		24	03.12.07
		V	T105
2.70		33	03.12.42
		V	T106
3.16		33	03.13.32
		V	T106
3.19		33	03.13.35
		V	T106
3.95		24	03.14.58
		V	T107
4.00		15	03.15.06
		V	T108
4.20		30	03.15.54
		V	T109
			

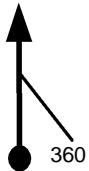
4.82**0.00****30** 03.17.08**V T110****FIM DE PROVA !!**www.t15.com.br

PARABÉNS VOCÊ CONSEGUIU, ATÉ
2018.

A DIRETORIA DO MTC AGRADECE A
PARTICIPAÇÃO DE TODOS OS
PILOTOS PELA PARTICIPAÇÃO NO
CAMPEONATO, E DESDE JÁ
CONVIDA A TODOS PARA
PARTICIPAR DA FESTA DE
ENCERRAMENTO E ENTREGA DA
PREMIAÇÃO DAS COPAS DE ENDURO
DE REGULARIDADE E ENDURO FIM
QUE SERÁ NO DIA 25/11/2017

Tempo de Prova

MÉDIA B 03:17:08

FIM