

INICIO

MÉDIA C

10º ENDURO DO CARVÃO
10 DE MARÇO 2018



IMPORTANTE

CUIDADO

ATENÇÃO

MUITA ATENÇÃO

Tempo de Prova

MÉDIA C 03:21:50



AFERIÇÃO

AFERIÇÃO

ZERAR NA PARADA DE ÔNIBUS

0.00		1	AFER
------	--	---	------

LOMBADA

0.06		2	AFER
------	--	---	------

0.19		3	AFER
------	--	---	------

0.43		4	AFER
------	--	---	------

0.50		5	AFER
------	--	---	------

0.76		6	AFER
------	--	---	------

1.47			AFER
------	--	--	------

AFERIR NA PLACA

RETORNE COM CUIDADO
PELO MESMO CAMINHO

1.60		8	AFER
------	--	---	------



INÍCIO DE PROVA

LARGADA DEBAIXO DA TENDA
DOS TRILHEIROS DO CARVÃO

0.00		9	V T1
------	--	---	------

0.07		10	V T2
------	--	----	------

0.18		11	V T2
------	--	----	------

0.42		12	V T2
------	--	----	------

0.48		13	V T3
------	--	----	------

0.76		14	V T3
------	--	----	------

0.84		15	V T4
------	--	----	------

CAIXAS D'ÁGUA

1.50		16	V T5
------	--	----	------





1.70		17	V T5
------	--	----	------





2.40		18	V T5
------	--	----	------

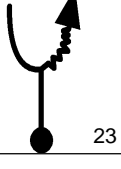

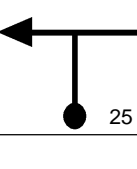
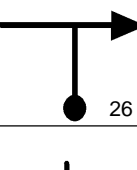
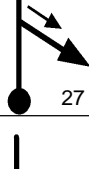
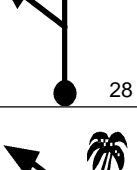
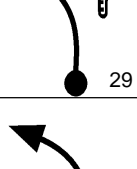
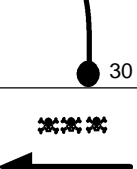
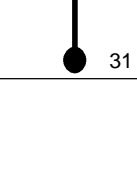

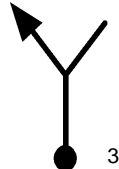
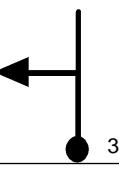
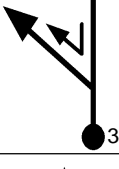
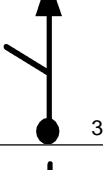
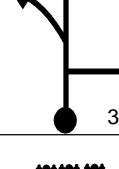
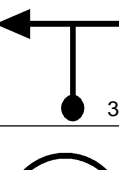
TRILHA DO CASTELO

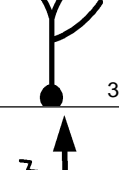

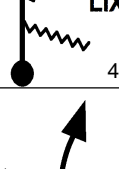
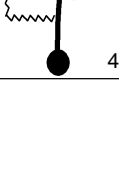

2.81		19	V T6
------	--	----	------

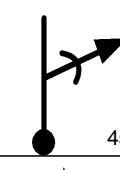
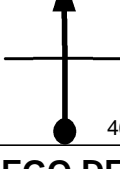
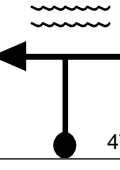
2.82		20	V T6
------	--	----	------

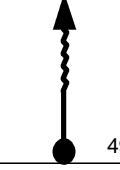
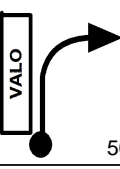
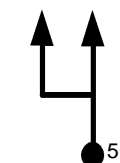

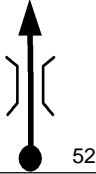
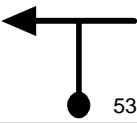
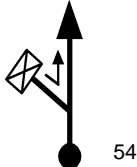
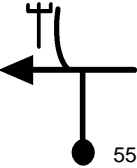
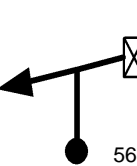
10 DE MARÇO 2018		Pág: 004	
2.94		15	00.05.29
		V	T6
2.98		15	00.05.39
		V	T6
3.11		15	00.06.10
		V	T6
3.21		15	00.06.34
		V	T6
3.28		27	00.06.51
		V	T7
3.31		27	00.06.55
		V	T7
3.39		27	00.07.06
		V	T7
3.47		27	00.07.16
		V	T7
3.58		27	00.07.31
		V	T7
3.64		27	00.07.39
		V	T7
3.69		33	00.07.46
		V	T8

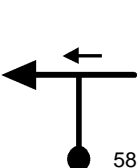
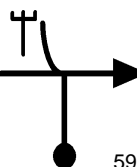

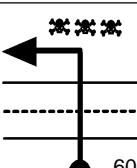

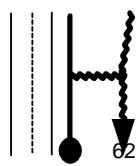
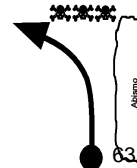
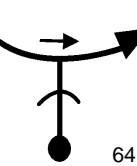
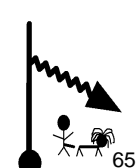
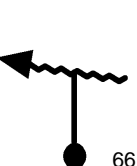
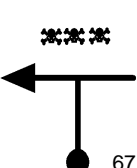
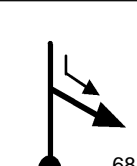
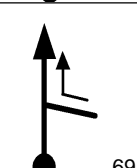
10 DE MARÇO 2018		Pág: 005	
3.80		33	00.07.58
		V	T8
3.86		33	00.08.04
		V	T8
3.99		33	00.08.18
		V	T8
4.07		33	00.08.27
		V	T8
4.22		17	00.08.44
		V	T9
4.33		2'	00.09.07
		N	T10
4.33		17	00.11.07
		V	T11
4.42		39	00.11.26
		V	T12
4.46		39	00.11.30
		V	T12
4.47		39	00.11.30
		V	T12
4.54		39	00.11.37
		V	T12

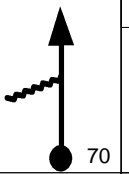
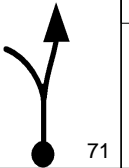
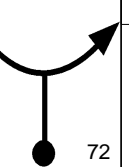

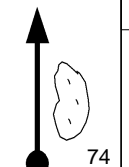
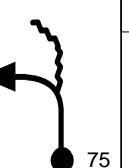
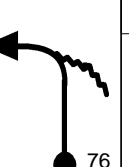
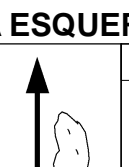
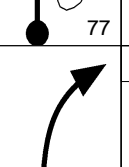
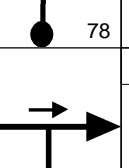

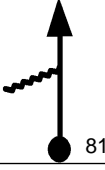

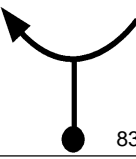
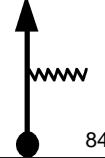
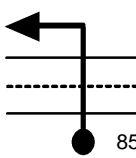

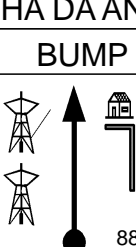
10 DE MARÇO 2018		Pág: 006	
BUMP			
CUIDADO - DESCE			
PERIGO			
4.75		15	00.11.56
		V	T13
4.88		15	00.12.28
		V	T13
4.92		15	00.12.37
		V	T13
4.94		15	00.12.42
		V	T13
CÓRREGO DE PIRITA			
4.96		24	00.12.47
		V	T14
5.15		12	00.13.15
		V	T15
NO MATO			
5.21		12	00.13.33
		V	T15
VALO			
5.44		12	00.14.42
		V	T15
VOCE DECIDE			
5.65		9	00.15.45
		V	T16

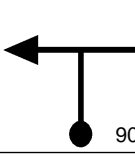

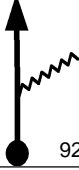

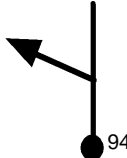
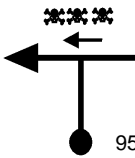
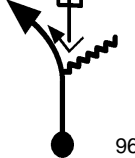
10 DE MARÇO 2018		Pág: 007	
5.83		9	00.16.57
		V	T16
5.90		24	00.17.25
		V	T17
6.00		24	00.17.40
		V	T17
6.04		24	00.17.46
		V	T17
6.09		24	00.17.54
		V	T17
6.13		24	00.18.00
		V	T17
6.15		24	00.18.03
		V	T17
6.18		24	00.18.07
		V	T17
			
SIGA PELO ACOSTAMENTO			
6.23		2'	00.18.15
		N	T18

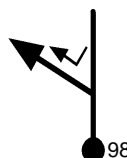

10 DE MARÇO 2018		Pág: 008	
6.23		45	00.20.15
0.00		V	T19
CUIDADO			
BARRANCO À DIREITA			
0.84		17	00.21.22
		V	T20
PENHASCO			
À DIREITA			
0.92		17	00.21.39
		V	T20
1.04		39	00.22.04
		V	T21
TRILHA DO FINQUETE			
DESCE			
1.20		15	00.22.19
		V	T22
1.38		15	00.23.02
		V	T22
1.47		33	00.23.24
		V	T23
TRILHA DO CARRINHO DE BEBE			
1.50		33	00.23.27
		V	T23
1.69		33	00.23.48
		V	T23

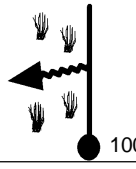
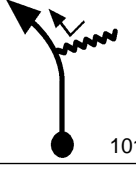

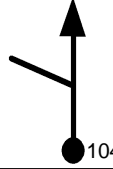
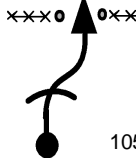
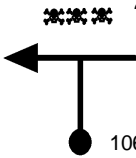

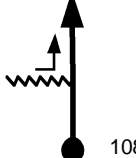
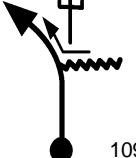
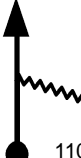
10 DE MARÇO 2018		Pág: 009	
1.74		27	00.23.53
		V	T24
2.30		27	00.25.08
		V	T24
2.34		17	00.25.13
		V	T25
ATOLEIRO			
2.45		17	00.25.37
		V	T25
ATOLEIRO			
PELA ESQUERDA			
2.93		17	00.27.18
		V	T25
2.97		17	00.27.27
		V	T25
2.98		27	00.27.29
		V	T26
PELA ESQUERDA			
3.01		27	00.27.33
		V	T26
3.09		27	00.27.43
		V	T26
3.19		3'	00.27.57
		N	T27

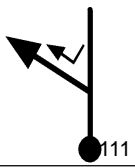

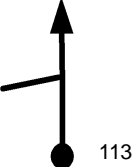
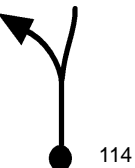
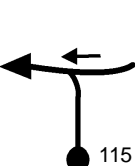
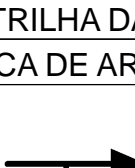
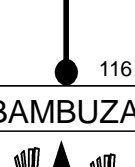
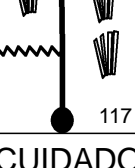
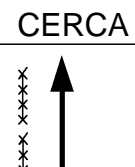

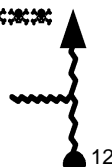
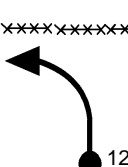
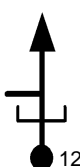

10 DE MARÇO 2018		Pág: 010	
3.19		27	00.30.57
		V	T28
3.24		27	00.31.03
		V	T28
3.80		27	00.32.18
		V	T28
3.84		18	00.32.23
		V	T29
4.13		18	00.33.21
		V	T29
4.15		2'	00.33.25
		N	T30
4.15		39	00.35.25
		V	T31
COSTEAR O MURO			
4.53		15	00.36.01
		V	T32
TRILHA DA ANTENA			
BUMP			
4.68		15	00.36.37
		V	T32
CUIDADO MOTOS MESMO SENTIDO			

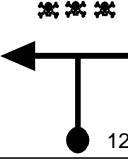
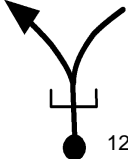
10 DE MARÇO 2018		Pág: 011	
4.84		15	00.37.15
		V	T32
4.99		15	00.37.51
		V	T32
5.54		27	00.40.03
		V	T33
5.64		27	00.40.16
		V	T33
5.68		27	00.40.22
		V	T33
5.71		27	00.40.26
		V	T33
5.78		33	00.40.35
		V	T34
5.82		33	00.40.39
		V	T34
5.98		33	00.40.57
		V	T34
6.11		33	00.41.11
		V	T34
6.30		33	00.41.32
		V	T34

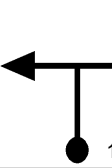

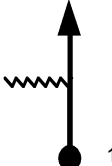
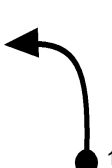
10 DE MARÇO 2018		Pág: 012	
6.35		33	00.41.37
		V	T34
6.66		33	00.42.11
		V	T34
6.76		33	00.42.22
		V	T34
6.80		33	00.42.26
		V	T34
6.83		33	00.42.30
		V	T34
6.86		33	00.42.33
		V	T34
6.87		2'30s	00.42.34
0.00		N	T35
0.00		33	00.45.04
		V	T36
0.03		33	00.45.07
		V	T36
0.07		33	00.45.11
		V	T36
0.23		33	00.45.29
		V	T36

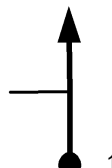
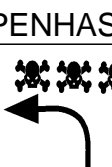

10 DE MARÇO 2018		Pág: 013	
0.36		33	00.45.43
		V	T36
0.55		27	00.46.04
		V	T37
0.60		27	00.46.11
		V	T37
1.17		18	00.47.27
		V	T38
1.59		15	00.48.51
		V	T39
TRILHA DA CERCA DE ARAME			
1.74		15	00.49.27
		V	T39
BAMBUZAL			
1.95		15	00.50.17
		V	T39
CUIDADO CERCA			
2.06		15	00.50.43
		V	T39
2.20		15	00.51.17
		V	T39

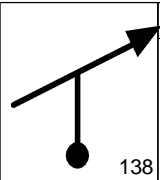
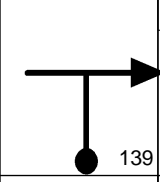
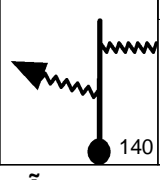
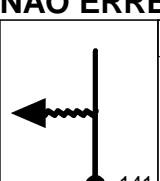
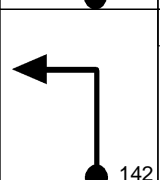
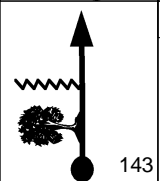
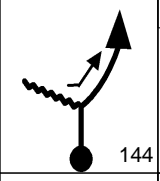
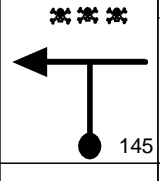
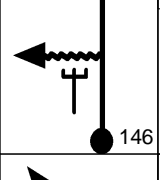
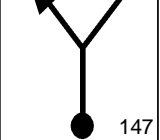
10 DE MARÇO 2018		Pág: 014	
			
TRILHA DO CAPACETE			
2.66		10	00.53.07
		V	T40
DECLIVE LISO			
2.71		10	00.53.25
		V	T40
CUIDADO DESCIDA			
2.82		21	00.54.05
		V	T41
2.88		21	00.54.15
		V	T41
2.99		1'	00.54.34
		N	T42
2.99		30	00.55.34
		V	T43
3.49		21	00.56.34
		V	T44
3.57		21	00.56.48
		V	T44

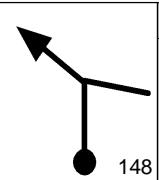
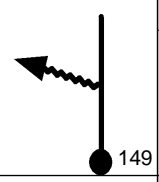
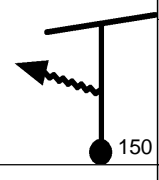
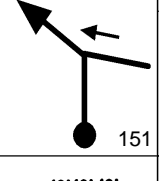
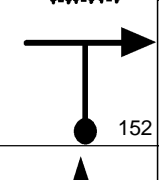
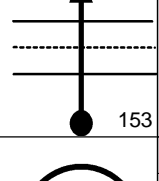
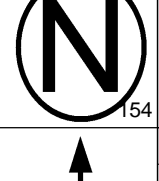

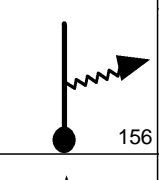
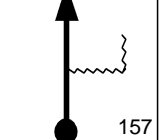
10 DE MARÇO 2018		Pág: 015	
3.99		21	00.58.00
		V	T44
4.12		21	00.58.22
		V	T44
4.26		21	00.58.46
		V	T44
4.38		21	00.59.07
		V	T44
4.61		34	00.59.46
0.00		V	T45
0.19		34	01.00.06
		V	T45
0.25		34	01.00.13
		V	T45
0.36		20	01.00.24
		V	T46
PENHASCO			
0.67		9	01.01.20
		V	T47
0.74		9	01.01.48
		V	T47

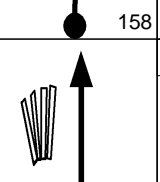
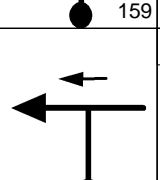
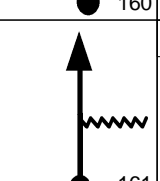
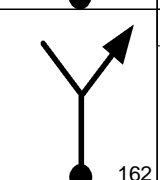
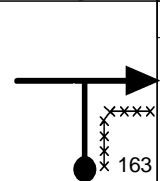
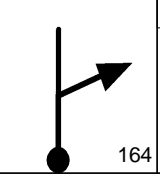

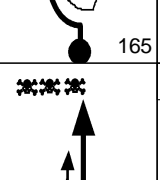
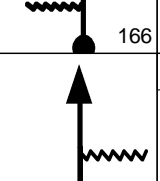

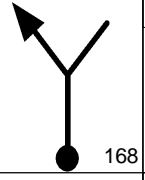
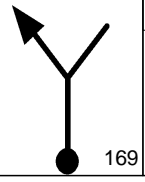
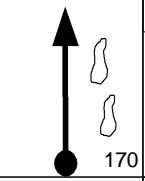
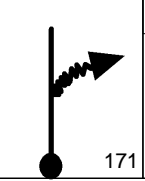
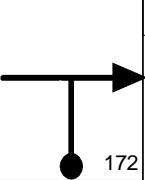
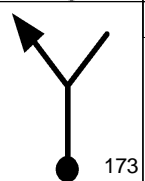
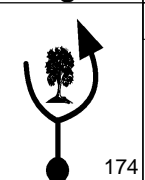
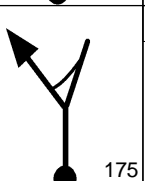
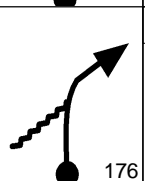
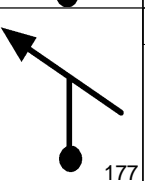
10 DE MARÇO 2018		Pág: 016	
0.83		9	01.02.24
		V	T47
0.85		9	01.02.32
		V	T47
0.87		9	01.02.40
		V	T47
NÃO ERRE!!			
0.91		9	01.02.56
		V	T47
1.01		9	01.03.36
		V	T47
1.19		9	01.04.48
		V	T47
1.21		15	01.04.56
		V	T48
1.34		15	01.05.27
		V	T48
1.35		17	01.05.30
		V	T49
1.44		17	01.05.49
		V	T49

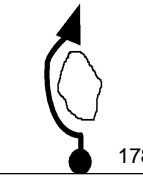
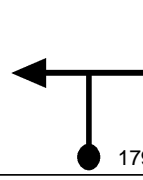
10 DE MARÇO 2018		Pág: 017	
1.47		17	01.05.55
		V	T49
1.50		16	01.06.01
		V	T50
1.62		10	01.06.28
		V	T51
1.63		12	01.06.32
		V	T52
1.75		33	01.07.08
		V	T53
1.86		2'	01.07.20
		N	T54
1.86		39	01.09.20
		V	T55
1.90		39	01.09.24
		V	T55
TRILHA DO RELÓGIO			
2.17		21	01.09.49
		V	T56
2.22		21	01.09.57
		V	T56

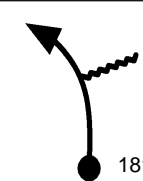
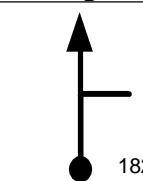
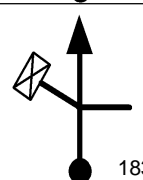
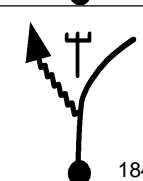
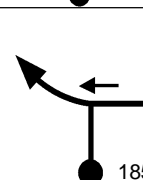
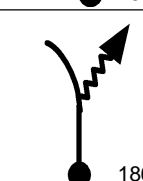
10 DE MARÇO 2018		Pág: 018	
DESCIDA LISA			
2.79		13	01.11.35
		V	T57
3.18		13	01.13.23
		V	T57
3.23		33	01.13.37
		V	T58
3.29		33	01.13.43
		V	T58
3.36		33	01.13.51
		V	T58
3.56		33	01.14.13
		V	T58
3.71		27	01.14.29
		V	T59
ATOLEIRO			
PELA ESQUERDA			
3.96		27	01.15.02
		V	T59
3.99		33	01.15.06
		V	T60
4.04		33	01.15.12
		V	T60

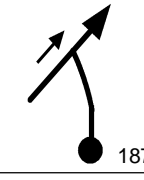
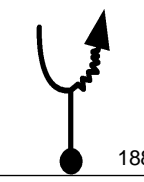
10 DE MARÇO 2018		Pág: 019	
4.12		36	01.15.21
	V	T61	
4.28		36	01.15.37
	V	T61	
EROSÕES			
4.83		24	01.16.32
	V	T62	
4.88		15	01.16.39
	V	T63	
SUBA			
4.92		12	01.16.49
	V	T64	
4.95		12	01.16.58
	V	T65	
4.97		15	01.17.04
	V	T66	
5.06		18	01.17.25
	V	T67	
5.09		18	01.17.31
	V	T67	
5.11		18	01.17.35
	V	T67	

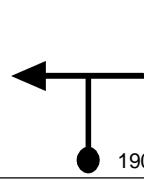
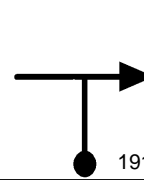
10 DE MARÇO 2018		Pág: 020	
ATOLEIRO			
PELA ESQUERDA			
5.23		18	01.17.59
	V	T67	
	2'	01.18.35	
5.41		N	T68
			
5.41		39	01.20.35
	V	T69	
	39	01.20.59	
5.67		V	T69
	39	01.21.56	
6.28		V	T69
	39	01.22.26	
6.61		V	T69
	15	01.23.04	
7.02		V	T70
	15	01.23.16	
7.07		V	T70
	15	01.23.42	
7.18		V	T70

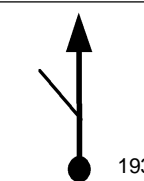
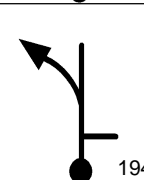
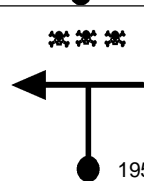
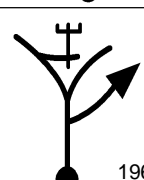
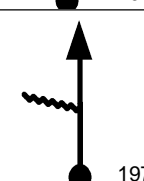





10 DE MARÇO 2018		Pág: 021	
7.22		15	01.23.52
	V	T70	
7.34		15	01.24.21
	V	T70	
	15	01.24.42	
7.43		V	T70
	27	01.24.59	
7.50		V	T71
	27	01.25.03	
7.53		V	T71
	27	01.25.14	
7.61		V	T71
	27	01.25.24	
7.69		V	T71
	15	01.25.46	
7.85		V	T72
	27	01.26.10	
7.95		V	T73
	27	01.26.19	
8.02		V	T73
	27	01.26.27	
8.08		V	T73

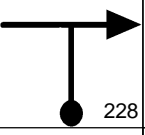
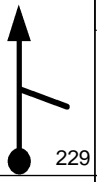
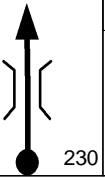
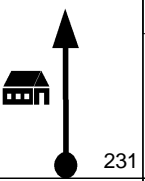
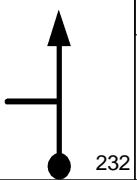
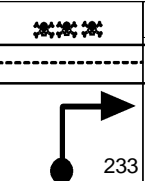
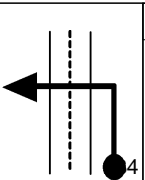
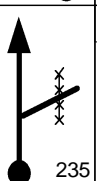
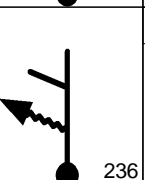

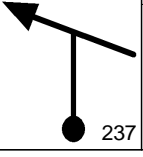
10 DE MARÇO 2018		Pág: 022	
8.10		27	01.26.30
	BUMP		
8.13		27	01.26.34
	SUBA		
8.18		27	01.26.40
8.24		27	01.26.48
8.41		30	01.27.11
8.41		39	01.28.41
8.68		39	01.29.06
9.87		39	01.30.56
9.94		39	01.31.02
10.18		39	01.31.24

10 DE MARÇO 2018		Pág: 023	
APOIO			
FIM DA 1ª ETAPA			
10.26		15'	01.31.32
10.26		15	01.47.32
0.00		V	T77
INÍCIO DA 2ª ETAPA			
ZERE NO POSTE			
APÓS ASFALTO			
0.00		15	01.47.32
0.03		V	T78
0.32		V	T78
0.46		V	T78
0.50		V	T78
0.83		V	T78
1.25		V	T78

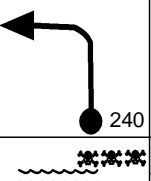
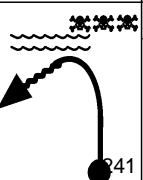
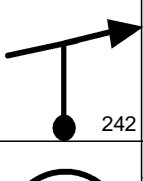
10 DE MARÇO 2018		Pág: 024	
1.37		33	01.50.05
1.42		33	01.50.11
1.75		V	T79
2.06		V	T79
2.08		V	T79
2.21		V	T80
2.25		V	T80
2.35		V	T80
2.42		N	T81
2.42		27	01.55.02
2.50		V	T82

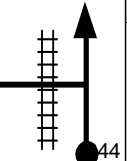
10 DE MARÇO 2018		Pág: 025	
2.56		27	01.55.21
		V	T82
2.71		27	01.55.41
		V	T82
3.01		27	01.56.21
		V	T82
VILA SRF			
3.38		27	01.57.10
		V	T82
3.48		27	01.57.23
		V	T82
INICIO DESLOCAMENTO			
3.65		4'	01.57.46
		D	T83
FIM DESLOCAMENTO			
4.06		39	02.01.46
		V	T84
4.72		39	02.02.47
		V	T84
4.73		33	02.02.48
		V	T85
CUIDADO COM OS PÉS TRILHA COM TOCOS			

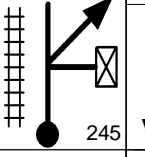
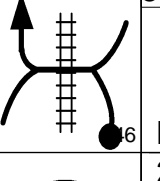

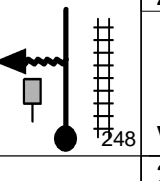
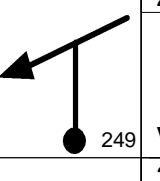
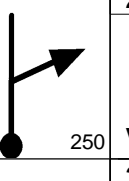
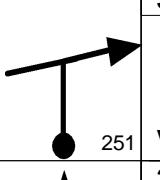
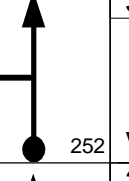
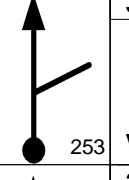
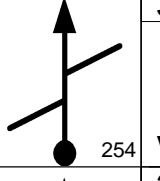
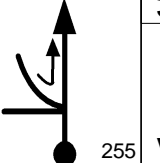

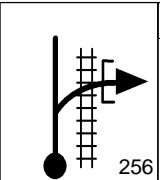
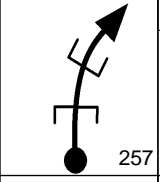
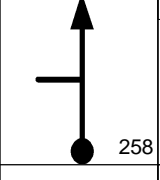
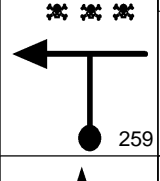
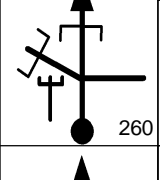
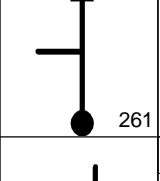
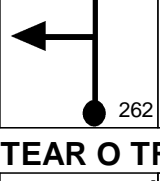
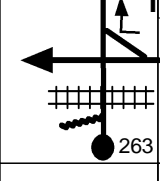
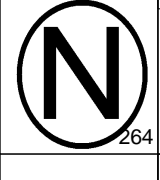
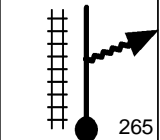

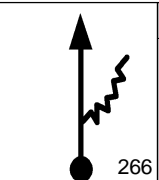
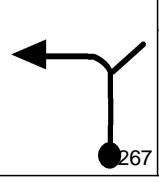
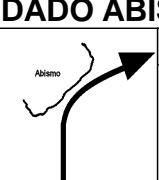
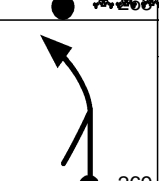
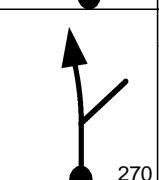
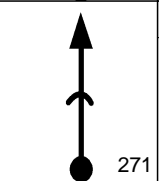
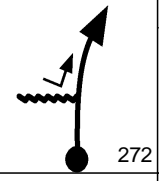
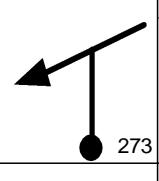
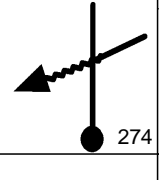
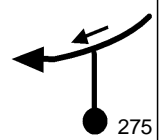
10 DE MARÇO 2018		Pág: 026	
4.76		33	02.02.51
		V	T85
PIRITA			
SIGA BUMP			
5.06		27	02.03.24
		V	T86
PELA MARGEM ESQUERDA			
5.17		27	02.03.38
		V	T86
			
5.23		27	02.03.46
		V	T86
5.37		33	02.04.05
		V	T87
		2'	02.04.27
5.57			
		N	T88
		36	02.06.27
5.57			
		V	T89
COSTEAR TRILHO			
5.62		36	02.06.32
		V	T89

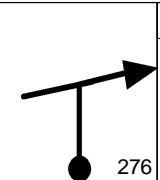
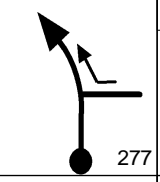
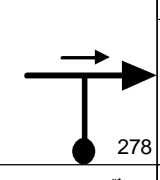
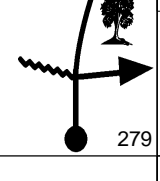
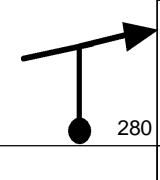
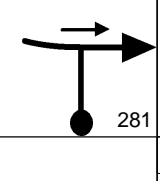
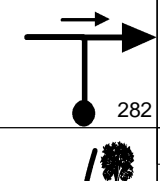
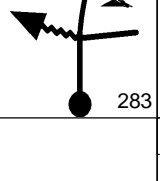
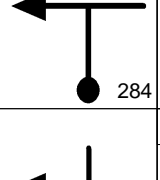
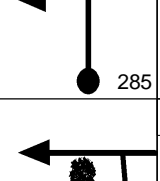
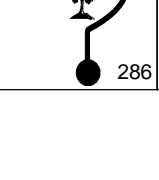

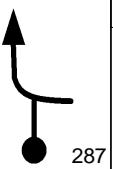
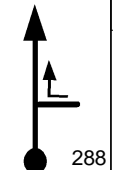

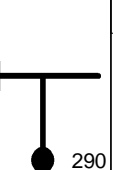
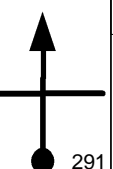
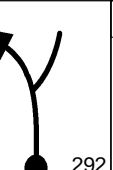
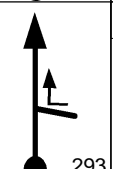

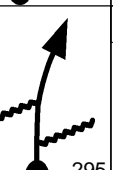

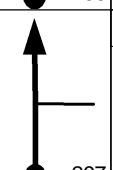
10 DE MARÇO 2018		Pág: 027	
5.80		36	02.06.50
		V	T89
6.05		30s	02.07.15
		N	T90
		21	02.07.45
6.05			
0.00		247	
		V	T91
		21	02.08.04
0.11			
		V	T91
		21	02.08.54
0.40			
		V	T91
		21	02.08.59
0.43			
		V	T91
		39	02.09.12
0.51			
		V	T92
		39	02.09.17
0.56			
		V	T92
		39	02.09.28
0.68			
		V	T92
		39	02.09.33
0.73			
		V	T92
		39	02.09.49
0.91			
		V	T92

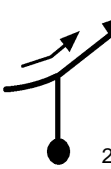

10 DE MARÇO 2018		Pág: 028	
1.27		39	02.10.23
		V	T92
1.57		39	02.10.50
		V	T92
1.68		39	02.11.00
		V	T92
2.08		36	02.11.37
		V	T93
2.11		36	02.11.40
		V	T93
2.48		36	02.12.17
		V	T93
2.66		36	02.12.35
		V	T93
COSTEAR O TRILHO			
2.99		1'30	02.13.08
		N	T94
2.99		33	02.14.38
		V	T95
3.19		15	02.15.00
		V	T96

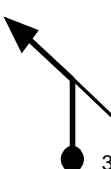



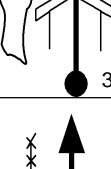

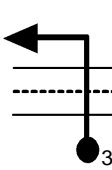
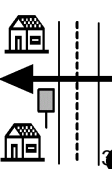
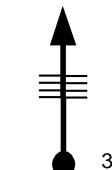
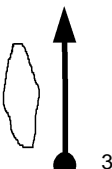
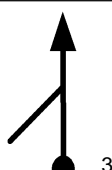
10 DE MARÇO 2018		Pág: 029	
3.20		15	02.15.03
		V	T96
3.30		24	02.15.27
		V	T97
CUIDADO ABISMO			
3.41		24	02.15.43
		V	T97
3.44		27	02.15.48
		V	T98
3.87		27	02.16.45
		V	T98
3.99		27	02.17.01
		V	T98
4.01		27	02.17.04
		V	T98
4.09		27	02.17.14
		V	T98
4.17		15	02.17.25
		V	T99
4.20		27	02.17.32
		V	T100

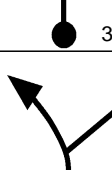
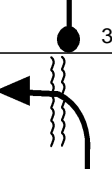

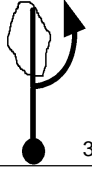

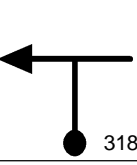
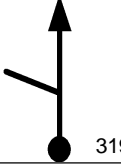
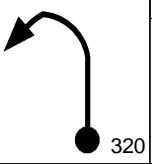
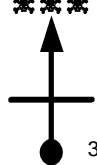
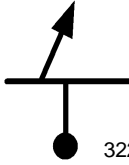

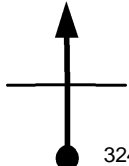
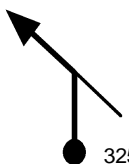
10 DE MARÇO 2018		Pág: 030	
4.28		27	02.17.43
		V	T100
4.34		27	02.17.51
		V	T100
4.46		24	02.18.07
		V	T101
4.49		24	02.18.11
		V	T101
4.61		24	02.18.29
		V	T101
4.65		24	02.18.35
		V	T101
4.78		24	02.18.55
		V	T101
4.81		21	02.18.59
		V	T102
4.86		24	02.19.08
		V	T103
4.95		15	02.19.21
		V	T104
4.98		15	02.19.28
		V	T104



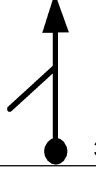
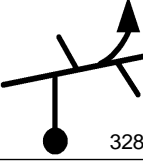

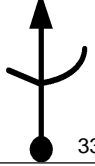
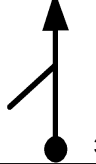
10 DE MARÇO 2018		Pág: 031	
5.00		15	02.19.33
		V	T104
5.03		21	02.19.40
		V	T105
5.07		21	02.19.47
		V	T105
5.11		24	02.19.54
		V	T106
5.20		24	02.20.08
		V	T106
5.27		24	02.20.18
		V	T106
5.35		21	02.20.30
		V	T107
5.45		21	02.20.47
		V	T107
5.54		21	02.21.03
		V	T107
5.65		21	02.21.22
		V	T107
5.75		15	02.21.39
		V	T108

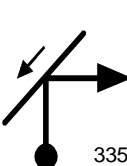
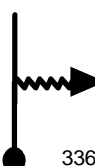

10 DE MARÇO 2018		Pág: 032	
5.83		21	02.21.58
		V	T109
5.93		21	02.22.15
		V	T109
			
6.02		21	02.22.31
		V	T109
6.12		21	02.22.48
		V	T109
6.20		2'	02.23.01
		N	T110
6.20		21	02.25.01
		V	T111
MUITO DEVAGAR			
RESPEITE A PROPRIEDADE			
6.24		21	02.25.08
		V	T112
6.60		15	02.26.10
		V	T113
NÃO ANDE NA BRITA			
VA PELA MARGEM ESQUERDA			

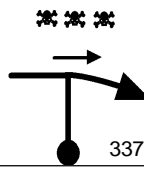

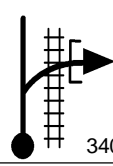

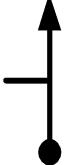
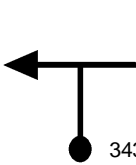
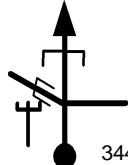
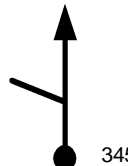
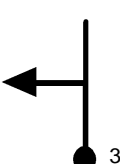
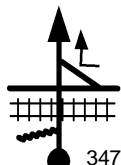

10 DE MARÇO 2018		Pág: 033	
6.84		15	02.27.08
		V	T113
6.98		39	02.27.41
		V	T114
7.73		39	02.28.50
		V	T114
7.76		18	02.28.53
		V	T115
7.87		18	02.29.15
		V	T115
7.93		18	02.29.27
		V	T115
DEVAGAR			
8.07		18	02.29.55
		V	T115
8.11		33	02.30.03
		V	T116
8.34		33	02.30.28
		V	T116
8.79		24	02.31.17
		V	T117

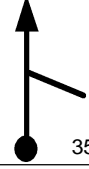
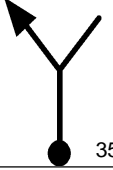
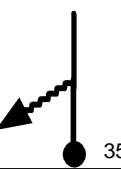
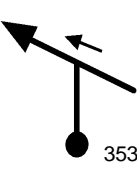
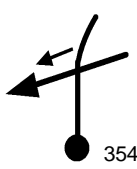
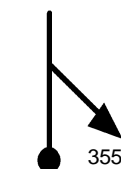
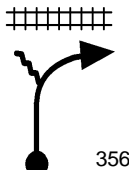
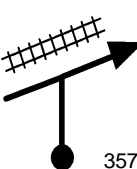
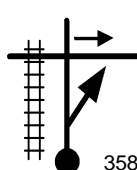

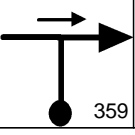

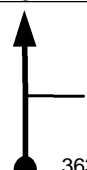
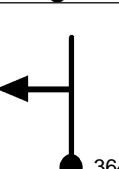
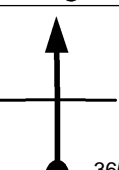
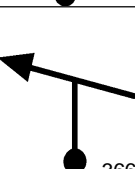

10 DE MARÇO 2018		Pág: 034	
8.88		24	02.31.31
		V	T117
9.10		24	02.32.04
		V	T117
9.17		24	02.32.14
		V	T117
9.23		24	02.32.23
		V	T117
9.42		24	02.32.52
		V	T117
9.56		24	02.33.13
		V	T117
9.58		30	02.33.16
		V	T118
9.60		30	02.33.18
		V	T118
9.62		30	02.33.21
		V	T118
9.67		30	02.33.27
		V	T118
9.70		30	02.33.30
		V	T118

10 DE MARÇO 2018		Pág: 035	
9.79		30	02.33.41
		V	T118
9.86		33	02.33.49
		V	T119
10.12		33	02.34.18
		V	T119
10.19		33	02.34.25
		V	T119
10.27		33	02.34.34
		V	T119
10.98		33	02.35.52
		V	T119
11.02		33	02.35.56
		V	T119
11.29		30	02.36.25
		V	T120
11.43		21	02.36.42
		V	T121
CUIDADO COM OS PÉS			
TOCOS NA TRILHA			
11.51		12	02.36.56
		V	T122

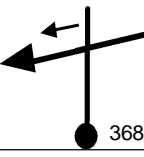
10 DE MARÇO 2018		Pág: 036	
11.63		39	02.37.32
		V	T123
11.78		2'	02.37.46
0.00		N	T124
0.00		39	02.39.46
		V	T125
0.35		39	02.40.18
		V	T125
0.65		39	02.40.46
		V	T125
0.75		39	02.40.55
		V	T125
1.16		39	02.41.33
		V	T125
1.19		39	02.41.36
		V	T125
1.55		39	02.42.09
		V	T125
1.73		1'	02.42.56
		V	T125
2.06		N	T126

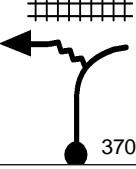
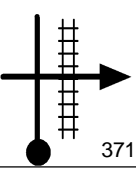
10 DE MARÇO 2018		Pág: 037	
2.06		27	02.43.56
		V	T127
2.28		27	02.44.25
		V	T127
2.29		27	02.44.27
		V	T127
2.34		27	02.44.33
		V	T127
2.45		27	02.44.48
		V	T127
2.53		27	02.44.59
		V	T127
2.70		27	02.45.21
		V	T127
2.71		21	02.45.23
		V	T128
2.87		21	02.45.50
		V	T128
2.92		24	02.45.59
		V	T129
2.95		27	02.46.03
		V	T130

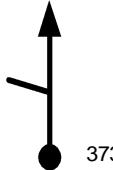
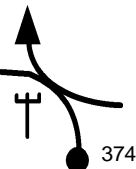
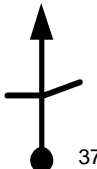
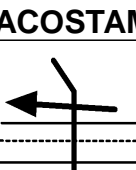
10 DE MARÇO 2018		Pág: 038	
2.97		27	02.46.06
		V	T130
			
3.16		27	02.46.31
		V	T130
3.17		27	02.46.32
		V	T130
3.22		27	02.46.39
		V	T130
3.28		27	02.46.47
		V	T130
3.45		27	02.47.10
		V	T130
3.51		27	02.47.18
		V	T130
3.57		27	02.47.26
		V	T130
3.67		27	02.47.39
		V	T130

10 DE MARÇO 2018		Pág: 039	
3.85		27	02.48.03
		V	T130
3.86		21	02.48.04
		V	T131
4.02		33	02.48.32
		V	T132
4.85		4'	02.50.02
		N	T133
4.85		21	02.54.02
		V	T134
4.94		21	02.54.18
		V	T134
5.82		27	02.56.49
		V	T135
6.04		27	02.57.18
		V	T135
PELO ACOSTAMENTO			
6.45		1'	02.58.13
		N	T136
PELO ACOSTAMENTO			
6.45		39	02.59.13
0.00		V	T137

10 DE MARÇO 2018		Pág: 040	
TRILHA DO			
MELA TANGA			
0.31		21	02.59.41
		V	T138
CUIDADO COM ATOLEIROS			
0.37		21	02.59.52
		V	T138
ATOLEIRO			
VÁ PELA ESQUERDA			
0.44		21	03.00.04
		V	T138
0.51		21	03.00.16
		V	T138
0.58		21	03.00.28
		V	T138
0.97		21	03.01.34
		V	T138
PELA ESQUERDA			
1.04		21	03.01.46
		V	T138
1.12		21	03.02.00
		V	T138
ATOLEIRO			
PELA DIREITA			
1.19		18	03.02.12
		V	T139

10 DE MARÇO 2018		Pág: 041	
1.45		18	03.03.04
		V	T139
1.50		18	03.03.14
		V	T139
1.53		18	03.03.20
		V	T139
1.62		36	03.03.38
		V	T140
1.68		36	03.03.44
		V	T140
1.71		42	03.03.47
		V	T141
NOVA BELUNO			
1.93		42	03.04.06
		V	T141
2.12		42	03.04.22
		V	T141
2.73		42	03.05.15
		V	T141
3.38		42	03.06.10
		V	T141

10 DE MARÇO 2018		Pág: 042	
3.95		24	03.06.59
		V	T142
4.42		24	03.08.10
		V	T142
4.58		24	03.08.34
		V	T142
4.63		24	03.08.41
		V	T142
4.66		24	03.08.46
		V	T142
4.75		33	03.08.59
		V	T143
4.81		33	03.09.06
		V	T143
4.84		2'	03.09.09
		N	T144
4.84		42	03.11.09
		V	T145
NOVA BELUNO			
5.06		42	03.11.28
		V	T145

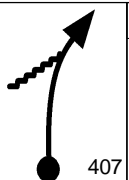
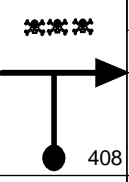
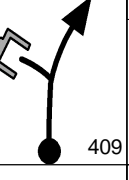
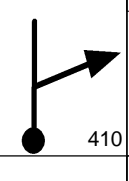
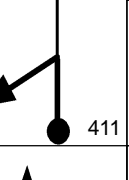
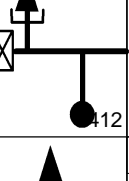
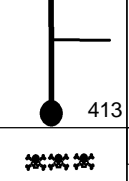
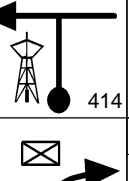
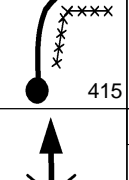
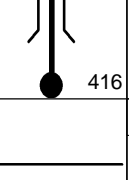
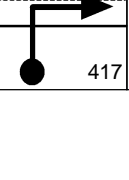
10 DE MARÇO 2018		Pág: 043	
5.25		42	03.11.44
		V	T145
5.86		42	03.12.36
		V	T145
7.00		42	03.14.14
		V	T145
7.19		42	03.14.30
		V	T145
7.70		42	03.15.14
		V	T145
8.84		30	03.16.52
		V	T146
9.08		30	03.17.21
		V	T146
9.48		36	03.18.09
		V	T147
10.26		36	03.19.27
		V	T147
10.48		36	03.19.49
		V	T147
11.59		36	03.21.40
		V	T147

10 DE MARÇO 2018		Pág: 044	
11.65		36	03.21.46
		V	T147
11.69		36	03.21.50
		V	T147
FIM DE PROVA !!			
			
www.t15.com.br			
<p>A EQUIPE TRILHEIROS DO CARVÃO AGRADECE A SUA PRESENÇA EM NOSSA PROVA!!</p> <p>ATÉ A PRÓXIMA</p> <p>www.trilheirosdocarvao.com.br</p>			
Tempo de Prova			
MÉDIA C 03:21:50			
FIM			