

**INICIO**

**MÉDIA B**

10º ENDURO DO CARVÃO  
10 DE MARÇO 2018



**IMPORTANTE**

CUIDADO

ATENÇÃO

MUITA ATENÇÃO

**Tempo de Prova**

MÉDIA B 03:18:49



**AFERIÇÃO**

AFERIÇÃO

ZERAR NA PARADA DE ÔNIBUS

0.00		1	AFER
------	--	---	------

LOMBADA

0.06		2	AFER
------	--	---	------

0.19		3	AFER
------	--	---	------

0.43		4	AFER
------	--	---	------

0.50		5	AFER
------	--	---	------

0.76		6	AFER
------	--	---	------

1.47			AFER
------	--	--	------

AFERIR NA PLACA

RETORNE COM CUIDADO  
PELO MESMO CAMINHO

1.60		8	AFER
------	--	---	------



**INÍCIO DE PROVA**

LARGADA DEBAIXO DA TENDA  
DOS TRILHEIROS DO CARVÃO

0.00		9	V T1
------	--	---	------

0.07		10	V T2
------	--	----	------

0.18		11	V T2
------	--	----	------

0.42		12	V T2
------	--	----	------

0.48		13	V T3
------	--	----	------

0.76		14	V T3
------	--	----	------

0.84		15	V T4
------	--	----	------

CAIXAS D'ÁGUA

1.50		16	V T5
------	--	----	------





1.70		17	V T5
------	--	----	------





2.40		18	V T5
------	--	----	------

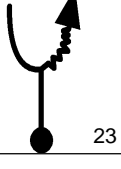

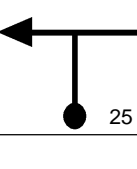
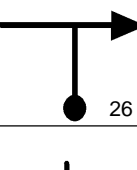
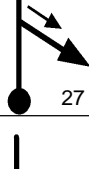
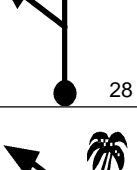
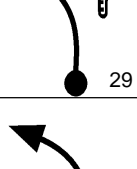
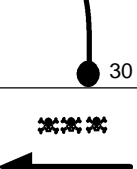
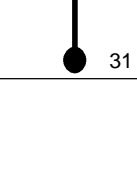

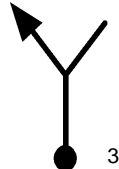
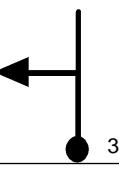
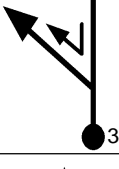
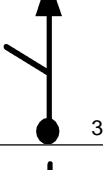
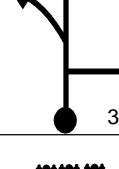
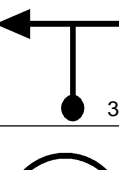
TRILHA DO CASTELO

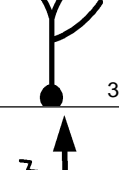

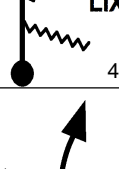
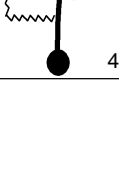

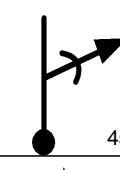
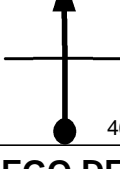
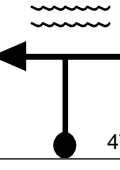

2.81		19	V T6
------	--	----	------

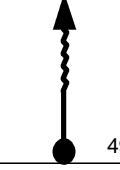
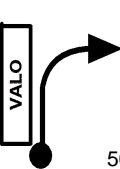
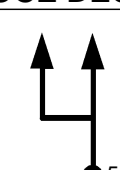

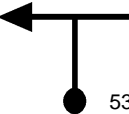
2.82		20	V T6
------	--	----	------

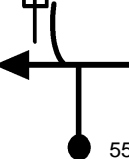
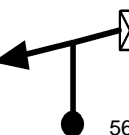
10 DE MARÇO 2018		Pág: 004	
2.94		18	
		V	T6
2.98		18	
		V	T6
3.11		18	
		V	T6
3.21		18	
		V	T6
3.28		30	00.06.26
		V	T7
3.31		30	
		V	T7
3.39		30	
		V	T7
3.47		30	
		V	T7
3.58		30	
		V	T7
3.64		30	
		V	T7
3.69		36	00.07.15
		V	T8

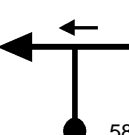
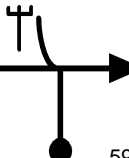
10 DE MARÇO 2018		Pág: 005	
3.80		36	
		V	T8
3.86		36	
		V	T8
3.99		36	
		V	T8
4.07		36	
		V	T8
4.22		17	00.08.08
		V	T9
4.33		2'	00.08.32
		N	T10
4.33		17	00.10.32
		V	T11
4.42		39	00.10.51
		V	T12
4.46		39	
		V	T12
4.47		39	
		V	T12
4.54		39	
		V	T12

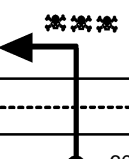
10 DE MARÇO 2018		Pág: 006	
<b>BUMP</b>			
<b>CUIDADO - DESCE</b>			
<b>PERIGO</b>			
4.75		18	00.11.21
		V	T13
4.88		18	
		V	T13
4.92		18	
		V	T13
4.94		18	
		V	T13
<b>CÓRREGO DE PIRITA</b>			
4.96		27	00.12.03
		V	T14
5.15		15	00.12.29
		V	T15
<b>NO MATO</b>			
5.21		15	
		V	T15
<b>VALO</b>			
5.44		15	
		V	T15
<b>VOCE DECIDE</b>			
5.65		12	00.14.29
		V	T16

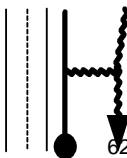
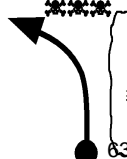
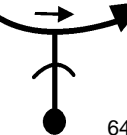
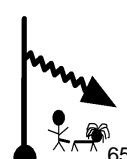
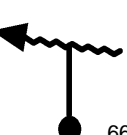
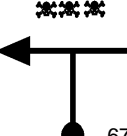
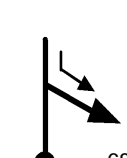
10 DE MARÇO 2018		Pág: 007	
5.83		12	
		V	T16
5.90		27	00.15.44
		V	T17
6.00		27	
		V	T17
6.04		27	
		V	T17
6.09		27	
		V	T17
6.13		27	
		V	T17
6.15		27	
		V	T17
6.18		27	
		V	T17
			
SIGA PELO ACOSTAMENTO			
6.23		2'	00.16.28
		N	T18

10 DE MARÇO 2018		Pág: 008	
6.23		45	00.18.28
0.00		V	T19
CUIDADO BARRANCO À DIREITA			
0.84		20	00.19.35
		V	T20
PENHASCO À DIREITA			
0.92		20	
		V	T20
1.04		39	00.20.11
		V	T21
TRILHA DO FINQUETE DESCE			
1.20		18	00.20.26
		V	T22
1.38		18	
		V	T22
1.47		36	00.21.20
		V	T23
TRILHA DO CARRINHO DE BEBE			
1.50		36	
		V	T23
1.69		36	
		V	T23

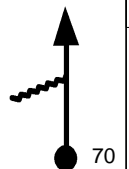
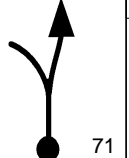
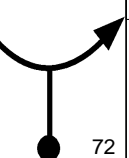
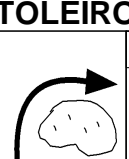
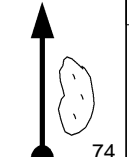
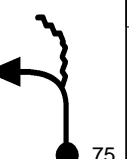
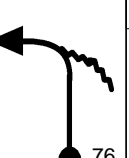
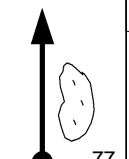
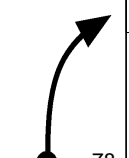
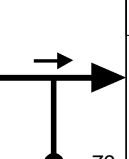

10 DE MARÇO 2018		Pág: 009	
1.74		30	00.21.47
		V	T24
2.30		30	
		V	T24
2.34		20	00.22.59
		V	T25
ATOLEIRO			
2.45		20	
		V	T25
ATOLEIRO PELA ESQUERDA			
2.93		20	
		V	T25
2.97		20	
		V	T25
2.98		30	00.24.54
		V	T26
PELA ESQUERDA			
3.01		30	
		V	T26
3.09		30	
		V	T26
3.19		3'	00.25.19
		N	T27

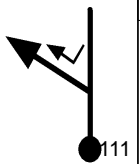
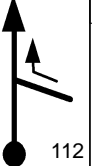
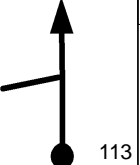
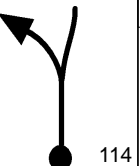
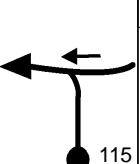
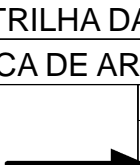
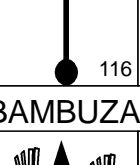
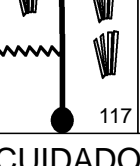
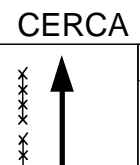

10 DE MARÇO 2018		Pág: 010	
3.19		30	00.28.19
		V	T28
3.24		30	
		V	T28
3.80		30	
		V	T28
3.84		24	00.29.37
		V	T29
4.13		24	
		V	T29
4.15		2'	00.30.23
		N	T30
4.15		39	00.32.23
		V	T31
COSTEAR O MURO			
4.53		18	00.32.59
		V	T32
TRILHA DA ANTENA			
BUMP			
4.68		18	
		V	T32
CUIDADO MOTOS MESMO SENTIDO			

10 DE MARÇO 2018		Pág: 011	
4.84		18	
		V	T32
4.99		18	
		V	T32
5.54		30	00.36.21
		V	T33
5.64		30	
		V	T33
5.68		30	
		V	T33
5.71		30	
		V	T33
5.78		36	00.36.49
		V	T34
5.82		36	
		V	T34
5.98		36	
		V	T34
6.11		36	
		V	T34
6.30		36	
		V	T34

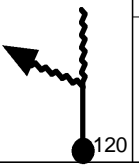
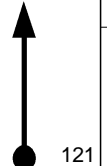
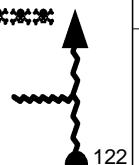
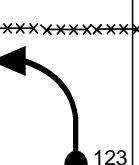
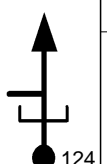
10 DE MARÇO 2018		Pág: 012	
6.35		36	
		V	T34
6.66		36	
		V	T34
6.76		36	
		V	T34
6.80		36	
		V	T34
6.83		36	
		V	T34
6.86		36	
		V	T34
6.87		2'30s	00.38.38
0.00		N	T35
0.00		36	00.41.08
		V	T36
0.03		36	
		V	T36
0.07		36	
		V	T36
0.23		36	
		V	T36

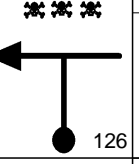
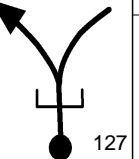
10 DE MARÇO 2018		Pág: 013	
0.36		36	V T36
0.55		30 00.42.03	V T37
0.60		30	V T37
1.17		21 00.43.18	V T38
1.59		18 00.44.30	V T39
TRILHA DA CERCA DE ARAME			
1.74		18	V T39
BAMBUZAL			
1.95		18	V T39
CUIDADO CERCA			
2.06		18	V T39
2.20		18	V T39

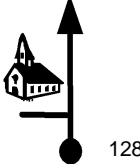
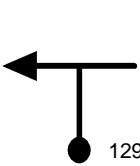
10 DE MARÇO 2018		Pág: 014	
			
TRILHA DO CAPACETE			
2.66		13 00.48.04	V T40
DECLIVE LISO			
2.71		13	V T40
CUIDADO DESCIDA			
2.82		24 00.48.48	V T41
2.88		24	V T41
2.99		2' 00.49.14	N T42
2.99		30 00.51.14	V T43
3.49		24 00.52.14	V T44
3.57		24	V T44

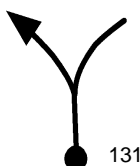
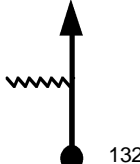
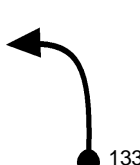
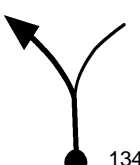
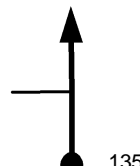
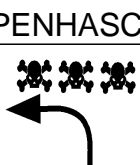
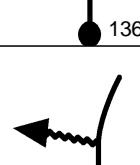

10 DE MARÇO 2018		Pág: 015	
3.99		24	V T44
4.12		24	V T44
4.26		24	V T44
4.38		24	V T44
4.61		37 00.55.02	V T45
0.19		37	V T45
0.25		37	V T45
0.36		23 00.55.37	V T46
PENHASCO			
0.67		12 00.56.25	V T47
0.74		12	V T47

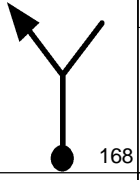
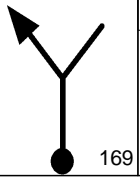
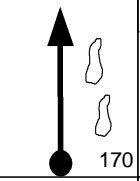
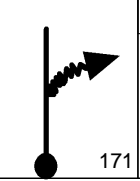
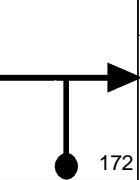
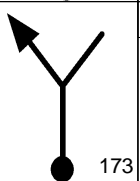
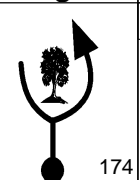
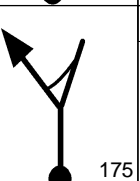
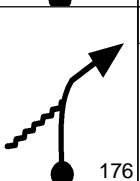
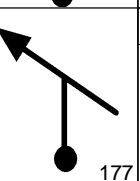

10 DE MARÇO 2018		Pág: 016	
0.83		12	V T47
0.85		12	V T47
0.87		12	V T47
<b>NÃO ERRE!!</b>			
0.91		12	V T47
1.01		12	V T47
1.19		12	V T47
1.21		15	V T48
1.34		15	V T48
1.35		20	V T49
1.44		20	V T49

10 DE MARÇO 2018		Pág: 017	
1.47		20	V T49
1.50		16	01.00.08 V T50
1.62		13	01.00.35 V T51
1.63		15	01.00.37 V T52
1.75		33	01.01.06 V T53
1.86		3'	01.01.18 N T54
1.86		39	01.04.18 V T55
1.90		39	V T55
<b>TRILHA DO RELÓGIO</b>			
2.17		24	01.04.47 V T56
2.22		24	V T56

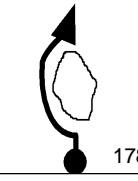
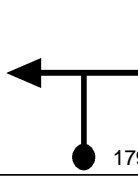
10 DE MARÇO 2018		Pág: 018	
<b>DESCIDA LISA</b>			
2.79		15	01.06.20 V T57
3.18		15	V T57
3.23		33	01.08.05 V T58
3.29		33	V T58
3.36		33	V T58
3.56		30	01.08.58 V T58
3.71		30	V T59
<b>ATOLEIRO</b>			
<b>PELA ESQUERDA</b>			
3.96		30	V T59
3.99		33	01.09.31 V T60
4.04		33	V T60

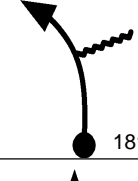
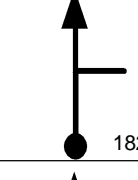
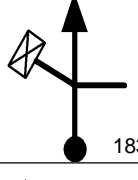
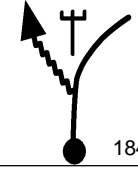
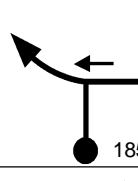
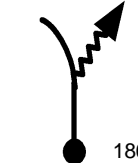
10 DE MARÇO 2018		Pág: 019	
4.12		36	01.09.46
		V	T61
4.28		36	
		V	T61
EROSÕES			
4.83		27	01.10.57
		V	T62
4.88		18	01.11.03
		V	T63
SUBA			
4.92		15	01.11.11
		V	T64
4.95		12	01.11.18
		V	T65
4.97		18	01.11.24
		V	T66
5.06		18	01.11.42
		V	T67
5.09		18	
		V	T67
5.11		18	
		V	T67

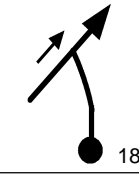
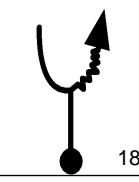
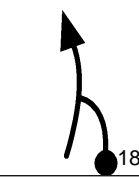
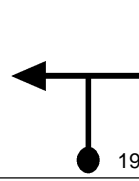
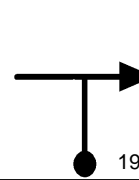
10 DE MARÇO 2018		Pág: 020	
ATOLEIRO			
PELA ESQUERDA			
5.23		18	
		V	T67
		3'	01.12.52
5.41		N	T68
			
5.41		39	01.15.52
		V	T69
5.67		39	
		V	T69
6.28		39	
		V	T69
6.61		39	
		V	T69
		18	01.18.21
7.02		18	
		V	T70
7.07		18	
		V	T70
7.18		18	
		V	T70

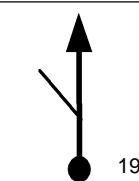
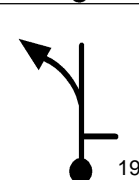
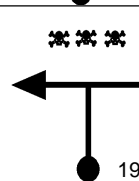
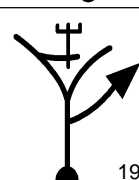
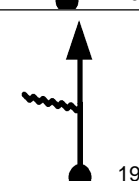
10 DE MARÇO 2018		Pág: 021	
7.22		18	
		V	T70
7.34		18	
		V	T70
7.43		30	01.19.57
		V	T70
7.50		30	
		V	T71
7.53		30	
		V	T71
7.61		30	
		V	T71
7.69		30	
		V	T71
7.85		18	01.20.39
		V	T72
7.95		30	01.20.59
		V	T73
8.02		30	
		V	T73
8.08		30	
		V	T73

10 DE MARÇO 2018		Pág: 022	
8.10		30	V T73
<b>BUMP</b>			
8.13		30	V T73
<b>SUBA</b>			
8.18		30	V T73
8.24		30	V T73
8.41		30	N T74
8.41		39	01.23.24
8.68		39	V T75
9.87		39	V T75
9.94		39	V T75
10.18		39	V T75

10 DE MARÇO 2018		Pág: 023	
<b>APOIO</b>			
<b>FIM DA 1ª ETAPA</b>			
10.26		20'	01.26.15
10.26		15	01.46.15
0.00		V	T77
<b>INÍCIO DA 2ª ETAPA</b>			
<b>ZERE NO POSTE</b>			
<b>APÓS ASFALTO</b>			
0.00		15	V T77
0.03		36	V T78
0.32		36	V T78
0.46		36	V T78
0.50		36	V T78
0.83		36	V T78
1.25		36	V T78





10 DE MARÇO 2018		Pág: 024	
1.37		36	V T78
1.42		36	V T78
1.75		36	01.49.14
2.06		36	V T79
2.08		33	01.50.00
2.21		33	V T80
2.25		33	V T80
2.35		3'	01.50.23
2.42		33	N T81
2.42		33	01.53.23
2.50		33	V T82





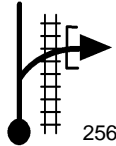

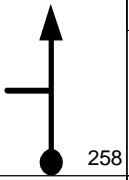
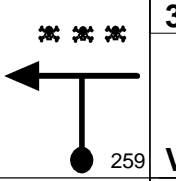
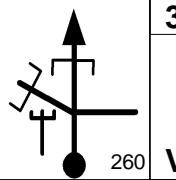
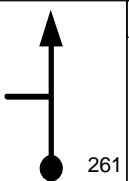
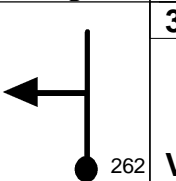
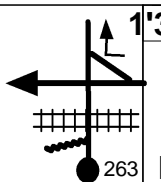

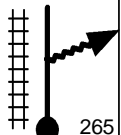
10 DE MARÇO 2018		Pág: 025	
2.56		33	V T82
2.71		33	V T82
3.01		33	V T82
VILA SRF			
3.38		33	V T82
3.48		33	V T82
INICIO DESLOCAMENTO			
3.65		4' 01.55.37	D T83
FIM DESLOCAMENTO			
4.06		39 01.59.37	V T84
4.72		39	V T84
4.73		33 02.00.39	V T85
CUIDADO COM OS PÉS TRILHA COM TOCOS			

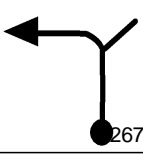
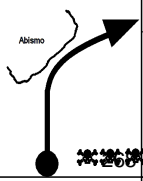



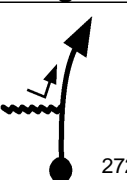
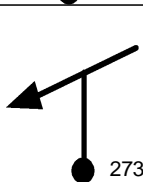
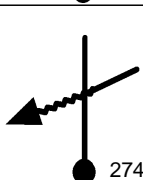
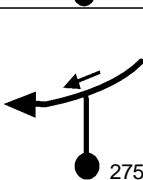

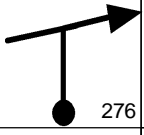
10 DE MARÇO 2018		Pág: 026	
4.76		33	V T85
PIRITA			
SIGA BUMP			
5.06		27 02.01.15	V T86
PELA MARGEM ESQUERDA			
5.17		27	V T86
5.23		27	V T86
5.37		33 02.01.56	V T87
5.57		2' 02.02.18	N T88
5.57		36 02.04.18	V T89
COSTEAR TRILHO			
5.62		36	V T89

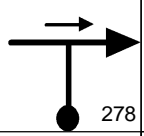
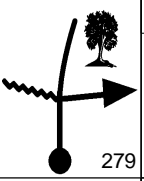
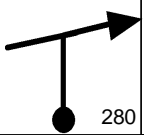
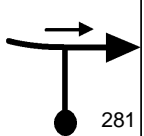
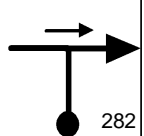
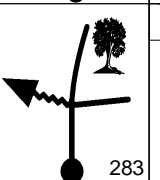
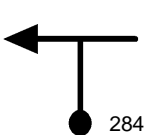
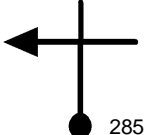
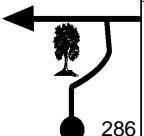

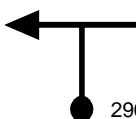
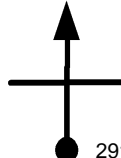

10 DE MARÇO 2018		Pág: 027	
5.80		36	V T89
6.05		1' 02.05.06	N T90
6.05		24 02.06.06	V T91
0.00		24	V T91
0.11		24	V T91
0.40		24	V T91
0.43		39 02.07.23	V T91
0.51		39	V T92
0.56		39	V T92
0.68		39	V T92
0.73		39	V T92
0.91		39	V T92

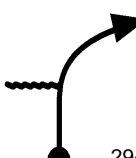
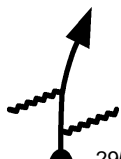

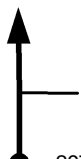

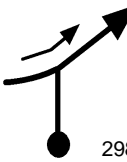
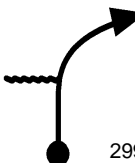
10 DE MARÇO 2018		Pág: 028	
1.27		39	V T92
1.57		39	V T92
1.68		39	V T92
2.08		36 02.09.48	V T93
2.11		36	V T93
2.48		36	V T93
2.66		36	V T93
<b>COSTEAR O TRILHO</b>			
2.99		1'30s 02.11.19	N T94
2.99		33 02.12.49	V T95
3.19		18 02.13.11	V T96

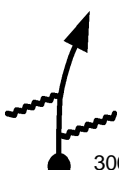
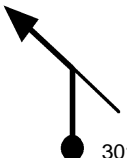

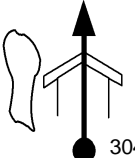
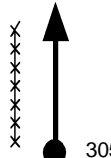

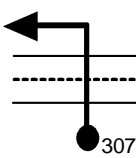
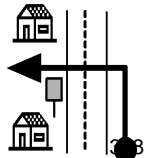

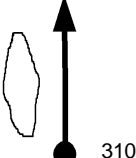
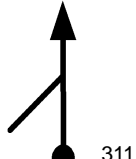
10 DE MARÇO 2018		Pág: 029	
3.20		18	V T96
3.30		27 02.13.33	V T97
<b>CUIDADO ABISMO</b>			
3.41		27	V T97
3.44		30 02.13.51	V T98
3.87		30	V T98
3.99		30	V T98
4.01		30	V T98
4.09		30	V T98
4.17		18 02.15.19	V T99
4.20		30 02.15.25	V T100

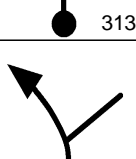
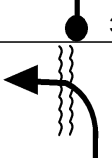

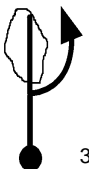

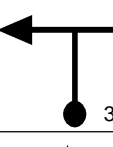
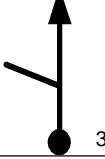
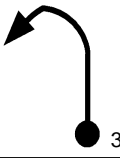
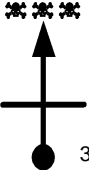
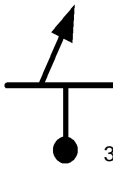

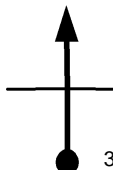

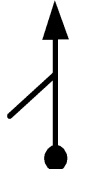

10 DE MARÇO 2018		Pág: 030	
4.28		30	V T100
4.34		30	V T100
4.46		27 02.15.56	V T101
4.49		27	V T101
4.61		27	V T101
4.65		27	V T101
4.78		24 02.16.43	V T101
4.81		30 02.16.50	V T102
4.86		18 02.17.01	V T103
4.95		18	V T104
4.98			V T104



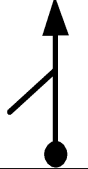

10 DE MARÇO 2018		Pág: 031	
5.00		18	V T104
5.03		24 02.17.17	V T105
5.07		24	V T105
5.11		27 02.17.29	V T106
5.20		27	V T106
5.27		24 02.18.01	V T106
5.35		24	V T107
5.45		24	V T107
5.54		24	V T107
5.65		24	V T107
5.75		15 02.19.01	V T108



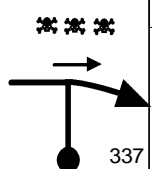
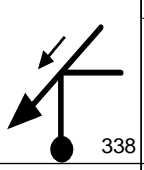

10 DE MARÇO 2018		Pág: 032	
5.83		24 02.19.20	V T109
5.93		24	V T109
			
6.02		24	V T109
6.12		24	V T109
6.20		2' 02.20.16	N T110
6.20		24 02.22.16	V T111
<b>MUITO DEVAGAR</b> <b>RESPEITE A PROPRIEDADE</b>			
6.24		21 02.22.22	V T112
6.60		15 02.23.23	V T113
<b>NÃO ANDE NA BRITA</b> <b>VA PELA MARGEM ESQUERDA</b>			

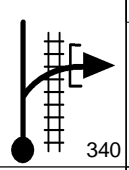

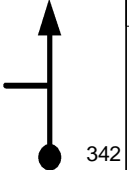
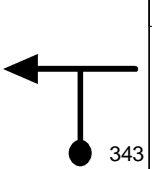
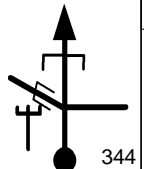
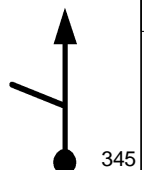
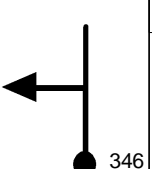
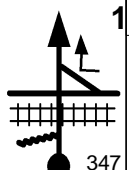

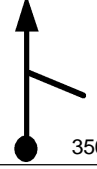
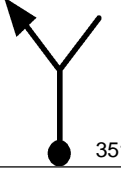
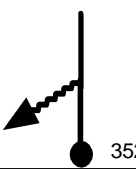

10 DE MARÇO 2018		Pág: 033	
6.84		15	V T113
6.98		39 02.24.55	V T114
7.73		39	V T114
7.76		18 02.26.07	V T115
7.87		18	V T115
7.93		18	V T115
<b>DEVAGAR</b>			
8.07		18	V T115
8.11		36 02.27.17	V T116
8.34		36	V T116
8.79		24 02.28.25	V T117

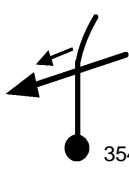
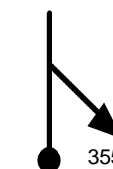
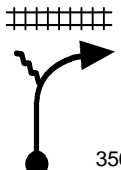
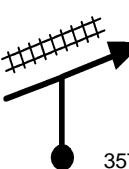
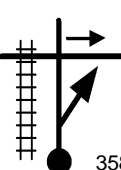

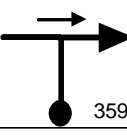



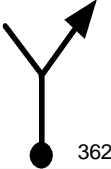
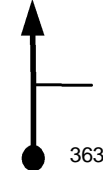
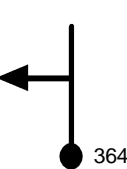
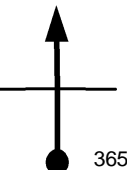

10 DE MARÇO 2018		Pág: 034	
8.88		24	V T117
9.10		24	V T117
9.17		24	V T117
9.23		24	V T117
9.42		24	V T117
9.56		24	V T117
9.58		33 02.30.23	V T118
9.60		33	V T118
9.62		33	V T118
9.67		33	V T118
9.70		33	V T118

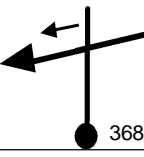
10 DE MARÇO 2018		Pág: 035	
9.79		33	V T118
9.86		36 02.30.54	V T119
10.12		36	V T119
10.19		36	V T119
10.27		36	V T119
10.98		36	V T119
11.02		36	V T119
11.29		33 02.33.17	V T120
11.43		24 02.33.32	V T121
<b>CUIDADO COM OS PÉS</b>			
<b>TOCOS NA TRILHA</b>			
11.51		12 02.33.44	V T122

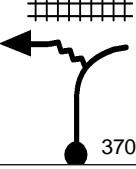
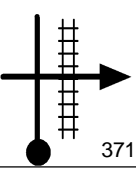
10 DE MARÇO 2018		Pág: 036	
11.63		33 02.34.20	V T123
11.78		2' 02.34.36	N T124
0.00		39 02.36.36	V T125
0.35		39	V T125
0.65		39	V T125
0.75		39	V T125
1.16		39	V T125
1.19		39	V T125
1.55		39	V T125
1.73		1'30s 02.39.46	V T125
2.06			N T126

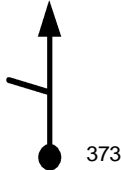
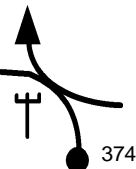
10 DE MARÇO 2018		Pág: 037	
2.06		30	02.41.16
		V	T127
2.28		30	
		V	T127
2.29		30	
		V	T127
2.34		30	
		V	T127
2.45		30	
		V	T127
2.53		30	
		V	T127
2.70		30	
		V	T127
2.71		24	02.42.34
		V	T128
2.87		24	
		V	T128
2.92		27	02.43.06
		V	T129
2.95		30	02.43.10
		V	T130

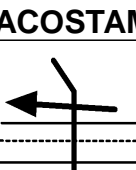
10 DE MARÇO 2018		Pág: 038	
2.97		30	
		V	T130
			
3.16		30	
		V	T130
3.17		30	
		V	T130
3.22		30	
		V	T130
3.28		30	
		V	T130
3.45		30	
		V	T130
3.51		30	
		V	T130
3.57		30	
		V	T130
3.67		30	
		V	T130

10 DE MARÇO 2018		Pág: 039	
3.85		30	
		V	T130
3.86		24	02.44.59
		V	T131
4.02		33	02.45.23
		V	T132
4.85		4'	02.46.54
		N	T133
4.85		21	02.50.54
		V	T134
4.94		27	02.53.40
		V	T134
5.82		27	
		V	T135
6.04		27	
		V	T135
PELO ACOSTAMENTO			
6.45		1'	02.55.04
		N	T136
PELO ACOSTAMENTO			
6.45		39	02.56.04
0.00		V	T137

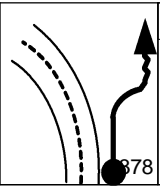
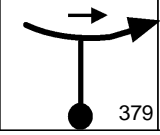
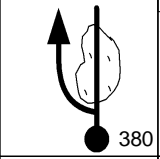
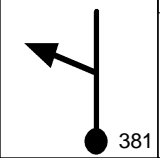
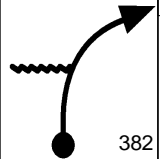
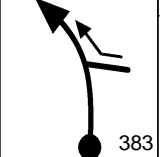
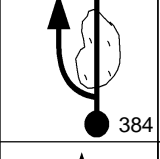
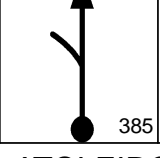
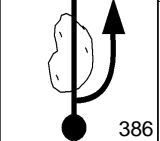
10 DE MARÇO 2018		Pág: 040	
<b>TRILHA DO MELA TANGA</b>			
<b>0.31</b>		24	02.56.32
		V	<b>T138</b>
<b>CUIDADO COM ATOLEIROS</b>			
<b>0.37</b>		24	
		V	T138
<b>ATOLEIRO</b>			
<b>VÁ PELA ESQUERDA</b>			
<b>0.44</b>		24	
		V	T138
<b>0.51</b>		24	
		V	T138
<b>0.58</b>		24	
		V	T138
<b>0.97</b>		24	
		V	T138
<b>PELA ESQUERDA</b>			
<b>1.04</b>		24	
		V	T138
<b>1.12</b>		24	
		V	T138
<b>ATOLEIRO</b>			
<b>PELA DIREITA</b>			
<b>1.19</b>		21	02.58.44
		V	<b>T139</b>

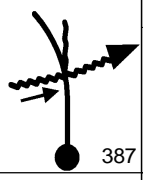
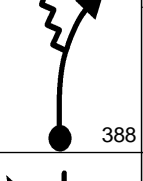
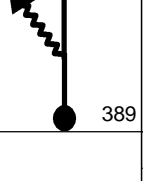
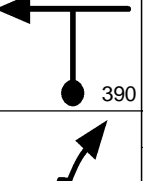
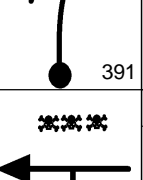
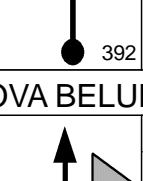
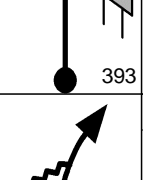
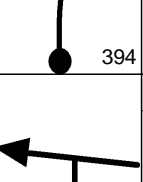
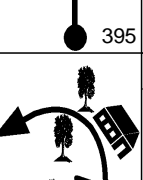
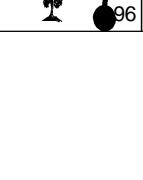
10 DE MARÇO 2018		Pág: 041	
<b>1.45</b>		21	
		V	T139
<b>1.50</b>		21	
		V	T139
<b>1.53</b>		21	
		V	T139
<b>1.62</b>		36	02.59.58
		V	<b>T140</b>
<b>1.68</b>		36	
		V	T140
<b>1.71</b>		42	03.00.07
		V	<b>T141</b>
<b>NOVA BELUNO</b>			
<b>1.93</b>		42	
		V	T141
<b>2.12</b>		42	
		V	T141
<b>2.73</b>		42	
		V	T141
<b>3.38</b>		42	
		V	T141

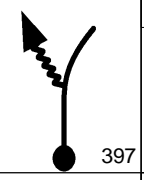
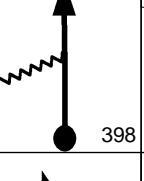
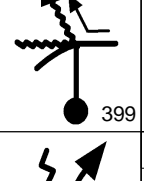
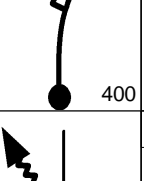
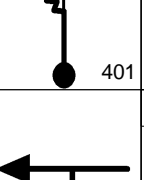
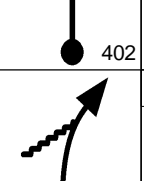
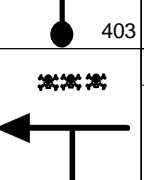
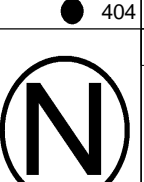
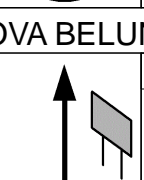
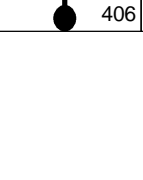
10 DE MARÇO 2018		Pág: 042	
<b>3.95</b>		27	03.03.19
		V	<b>T142</b>
<b>4.42</b>		27	
		V	T142
<b>4.58</b>		27	
		V	T142
<b>4.63</b>		27	
		V	T142
<b>4.66</b>		27	
		V	T142
<b>4.75</b>		36	03.05.06
		V	<b>T143</b>
<b>4.81</b>		36	
		V	T143
<b>4.84</b>		3'	03.05.15
		N	<b>T144</b>
<b>4.84</b>		42	03.08.15
		V	<b>T145</b>
<b>NOVA BELUNO</b>			
<b>5.06</b>		42	
		V	T145

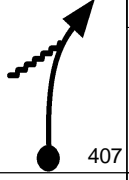
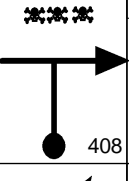
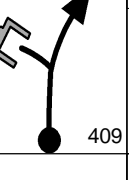
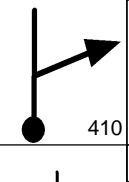
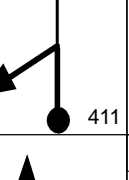
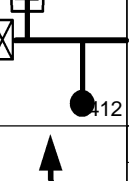
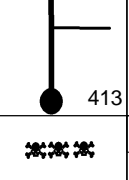
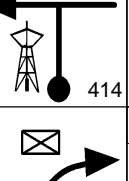
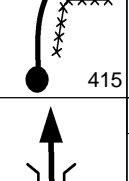
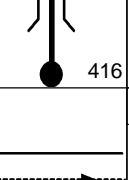
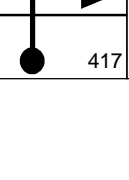
10 DE MARÇO 2018		Pág: 043	
5.25		42	V T145
5.86		42	V T145
7.00		42	V T145
7.19		42	V T145
7.70		42	V T145
8.84		33 03.13.58	V T146
9.08		33	V T146
9.48		36 03.15.08	V T147
10.26		36	V T147
10.48		36	V T147
11.59		36	V T147

10 DE MARÇO 2018		Pág: 044	
11.65		36	V T147
11.69		36 03.18.49	V T147
<b>FIM DE PROVA !!</b>			
			
<a href="http://www.t15.com.br">www.t15.com.br</a>			
A EQUIPE TRILHEIROS DO CARVÃO AGRADECE A SUA PRESENÇA EM NOSSA PROVA!!			
ATÉ A PRÓXIMA			
<a href="http://www.trilheirosdocarvao.com.br">www.trilheirosdocarvao.com.br</a>			
<b>Tempo de Prova</b>			
MÉDIA B 03:18:49			
<b>FIM</b>			