

INICIO

MÉDIA A

10º ENDURO DO CARVÃO
10 DE MARÇO 2018



IMPORTANTE

CUIDADO

ATENÇÃO

MUITA ATENÇÃO

Tempo de Prova

MÉDIA A 03:14:58



AFERIÇÃO

AFERIÇÃO

ZERAR NA PARADA DE ÔNIBUS

0.00	 1			AFER
-------------	-------	--	--	-------------

LOMBADA

0.06	 2			AFER
-------------	-------	--	--	-------------

0.19	 3			AFER
-------------	-------	--	--	-------------

0.43	 4			AFER
-------------	-------	--	--	-------------

0.50	 5			AFER
-------------	-------	--	--	-------------

0.76	 6			AFER
-------------	-------	--	--	-------------

1.47	 7			AFER
-------------	-------	--	--	-------------

AFERIR NA PLACA

**RETORNE COM CUIDADO
PELO MESMO CAMINHO**

1.60	 8			AFER
-------------	-------	--	--	-------------



INÍCIO DE PROVA

LARGADA DEBAIXO DA TENDA
DOS TRILHEIROS DO CARVÃO

0.00	 9			T1
-------------	-------	--	--	-----------

0.07	 10			T2
-------------	--------	--	--	-----------

0.18	 11			T2
-------------	--------	--	--	-----------

0.42	 12			T2
-------------	--------	--	--	-----------

0.48	 13			T3
-------------	--------	--	--	-----------

0.76	 14			T3
-------------	--------	--	--	-----------

0.84	 15			T4
-------------	--------	--	--	-----------

CAIXAS D'ÁGUA

1.50	 16			T5
-------------	--------	--	--	-----------









1.70	 17			T5
-------------	--------	--	--	-----------





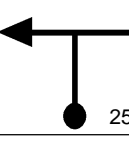
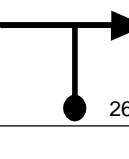

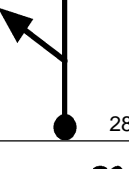
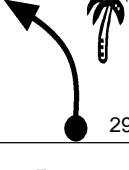
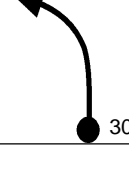
2.40	 18			T5
-------------	--------	--	--	-----------



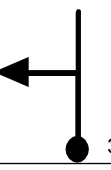
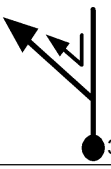
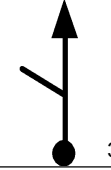

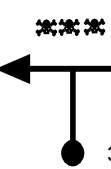
TRILHA DO CASTELO

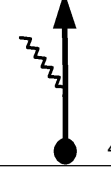
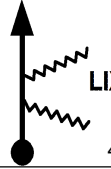

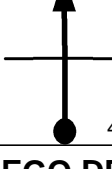
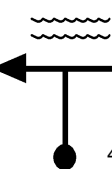

2.81	 19			T6
-------------	--------	--	--	-----------

2.82	 20			T6
-------------	--------	--	--	-----------

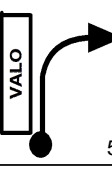
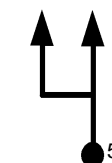
10 DE MARÇO 2018		Pág: 004	
2.94		21	
		V	T6
2.98		21	
		V	T6
3.11		21	
		V	T6
3.21		21	
		V	T6
3.28		36	00.06.04
		V	T7
3.31		36	
		V	T7
3.39		36	
		V	T7
3.47		36	
		V	T7
3.58		36	
		V	T7
3.64		36	
		V	T7
3.69		39	00.06.45
		V	T8

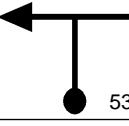

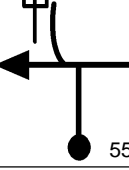
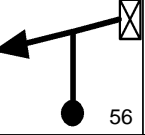
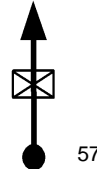
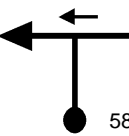
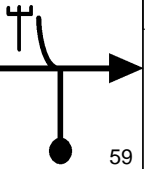

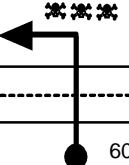

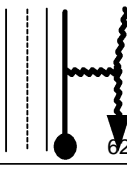
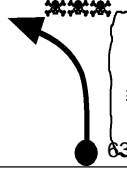
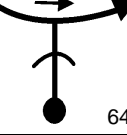
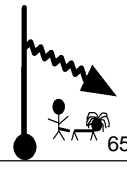
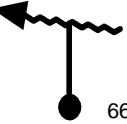
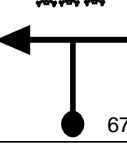
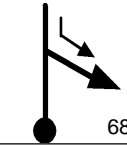
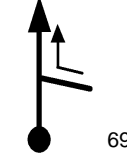
10 DE MARÇO 2018		Pág: 005	
3.80		39	
		V	T8
3.86		39	
		V	T8
3.99		39	
		V	T8
4.07		39	
		V	T8
4.22		23	00.07.33
		V	T9
4.33		2'	00.07.51
		N	T10
4.33		23	00.09.51
		V	T11
4.42		39	00.10.05
		V	T12
4.46		39	
		V	T12
4.47		39	
		V	T12
4.54		39	
		V	T12

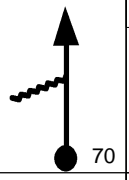
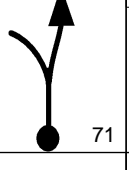
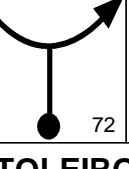
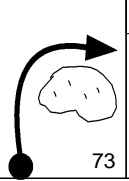
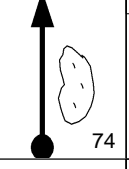
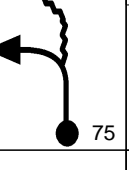
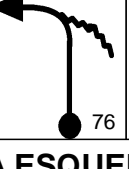
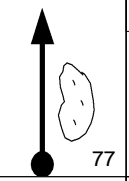
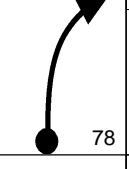
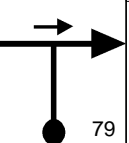

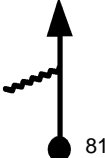

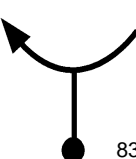

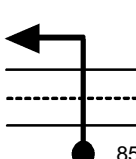
10 DE MARÇO 2018		Pág: 006	
BUMP			
CUIDADO - DESCE			
PERIGO			
4.75		22	00.10.35
		V	T13
4.88		22	
		V	T13
4.92		22	
		V	T13
4.94		22	
		V	T13
CÓRREGO DE PIRITA			
4.96		30	00.11.10
		V	T14
5.15		18	00.11.32
		V	T15
NO MATO			
5.21		18	
		V	T15
VALO			
5.44		18	
		V	T15
VOCE DECIDE			
5.65		15	00.13.12
		V	T16

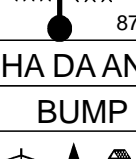

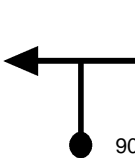

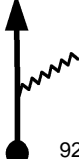

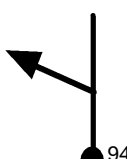
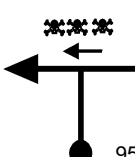
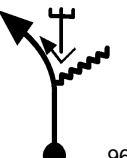
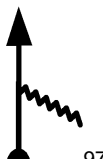

10 DE MARÇO 2018		Pág: 007	
5.83		15	
		V	T16
5.90		30	00.14.12
		V	T17
6.00		30	
		V	T17
6.04		30	
		V	T17
6.09		30	
		V	T17
6.13		30	
		V	T17
6.15		30	
		V	T17
6.18		30	
		V	T17
			
SIGA PELO ACOSTAMENTO			
6.23		2'	00.14.52
		N	T18

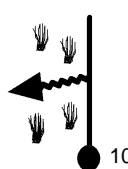
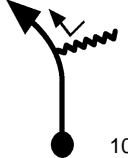

10 DE MARÇO 2018		Pág: 008	
6.23		45	00.16.52
0.00		V	T19
CUIDADO			
BARRANCO À DIREITA			
0.84		23	00.17.59
		V	T20
PENHASCO			
À DIREITA			
0.92		23	
		V	T20
1.04		39	00.18.30
		V	T21
TRILHA DO FINQUETE			
DESCE			
1.20		21	00.18.45
		V	T22
1.38		21	
		V	T22
1.47		39	00.19.32
		V	T23
TRILHA DO CARRINHO DE BEBE			
1.50		39	
		V	T23
1.69		39	
		V	T23

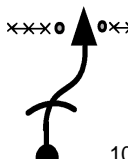
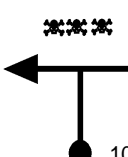

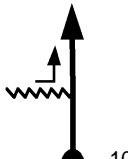
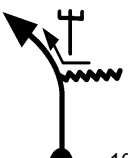

10 DE MARÇO 2018		Pág: 009	
1.74		39	00.19.56
		V	T24
2.30		39	
		V	T24
2.34		23	00.20.52
		V	T25
ATOLEIRO			
2.45		23	
		V	T25
ATOLEIRO			
PELA ESQUERDA			
2.93		23	
		V	T25
2.97		23	
		V	T25
2.98		33	00.22.32
		V	T26
PELA ESQUERDA			
3.01		33	
		V	T26
3.09		33	
		V	T26
3.19		3'	00.22.55
		N	T27

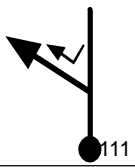

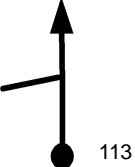
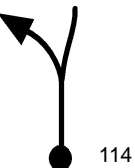
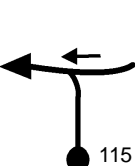
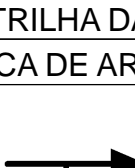
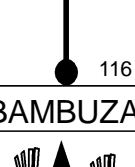
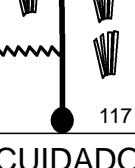
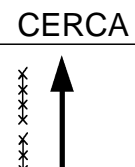

10 DE MARÇO 2018		Pág: 010	
3.19		39	00.25.55
		V	T28
3.24		39	
		V	T28
3.80		39	
		V	T28
3.84		27	00.26.55
		V	T29
4.13		27	
		V	T29
4.15		2'	00.27.36
		N	T30
4.15		39	00.29.36
		V	T31
COSTEAR O MURO			
4.53		21	00.30.11
		V	T32
TRILHA DA ANTENA			
BUMP			
4.68		21	
		V	T32
CUIDADO MOTOS MESMO SENTIDO			

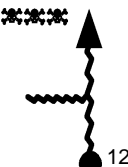
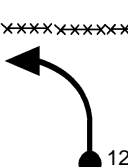
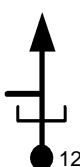
10 DE MARÇO 2018		Pág: 011	
4.84		21	
		V	T32
4.99		21	
		V	T32
5.54		33	00.33.04
		V	T33
5.64		33	
		V	T33
5.68		33	
		V	T33
5.71		33	
		V	T33
5.78		39	00.33.31
		V	T34
5.82		39	
		V	T34
5.98		39	
		V	T34
6.11		39	
		V	T34
6.30		39	
		V	T34

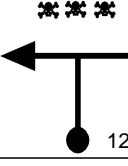
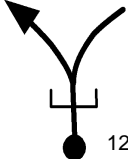
10 DE MARÇO 2018		Pág: 012	
6.35		39	
		V	T34
6.66		39	
		V	T34
6.76		39	
		V	T34
6.80		39	
		V	T34
6.83		39	
		V	T34
6.86		39	
		V	T34
6.87		2'30s	00.35.11
0.00		39	00.37.41
		V	T35
0.00		39	
		V	T36
0.03		39	
		V	T36
0.07		39	
		V	T36
0.23		39	
		V	T36

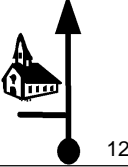
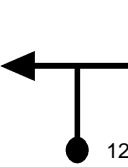
10 DE MARÇO 2018		Pág: 013	
0.36		39	V T36
0.55		39 00.38.32	V T37
0.60		39	V T37
1.17		24 00.39.29	V T38
1.59		21 00.40.32	V T39
TRILHA DA CERCA DE ARAME			
1.74		21	V T39
BAMBUZAL			
1.95		21	V T39
CUIDADO CERCA			
2.06		21	V T39
2.20		21	V T39

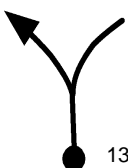
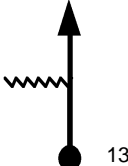
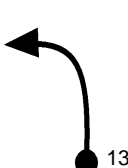
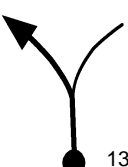
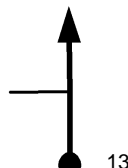
10 DE MARÇO 2018		Pág: 014	
			
TRILHA DO CAPACETE			
2.66		16 00.43.36	V T40
DECLIVE LISO			
2.71		16	V T40
CUIDADO DESCIDA			
2.82		27 00.44.12	V T41
2.88		27	V T41
2.99		4' 00.44.34	N T42
2.99		33 00.48.34	V T43
3.49		27 00.49.29	V T44
3.57		27	V T44

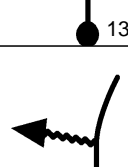



10 DE MARÇO 2018		Pág: 015	
3.99		27	V T44
4.12		27	V T44
4.26		27	V T44
4.38		27	V T44
4.61		40 00.51.58	V T45
0.19		40	V T45
0.25		40	V T45
0.36		26 00.52.31	V T46
PENHASCO			
0.67		15 00.53.14	V T47
0.74		15	V T47

10 DE MARÇO 2018		Pág: 016	
0.83		15	V T47
0.85		15	V T47
0.87		15	V T47
NÃO ERRE!!			
0.91		15	V T47
1.01		15	V T47
1.19		15	V T47
1.21		18 00.55.23	V T48
1.34		18	V T48
1.35		23 00.55.51	V T49
1.44		23	V T49

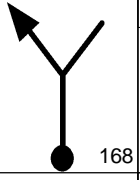
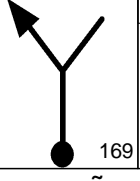
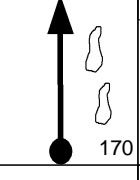
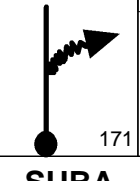
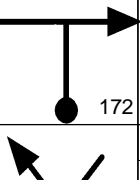
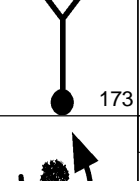
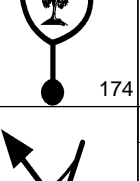
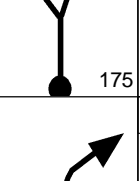
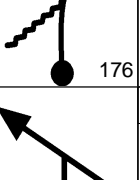
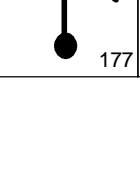
10 DE MARÇO 2018		Pág: 017	
1.47		23	V T49
1.50		16 00.56.15	V T50
1.62		16 00.56.42	V T51
1.63		18 00.56.44	V T52
1.75		36 00.57.08	V T53
1.86		4' 00.57.19	N T54
1.86		39 01.01.19	V T55
1.90		39	V T55
TRILHA DO RELÓGIO			
2.17		30 01.01.47	V T56
2.22		30	V T56

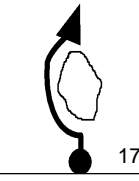
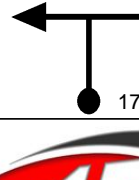
10 DE MARÇO 2018		Pág: 018	
DESCIDA LISA			
2.79		18 01.03.02	V T57
3.18		18	V T57
3.23		36 01.04.30	V T58
3.29		36	V T58
3.36		36	V T58
3.56		33 01.05.18	V T58
3.71		33	V T59
ATOLEIRO			
PELA ESQUERDA			
3.96		33	V T59
3.99		36 01.05.48	V T60
4.04		36	V T60

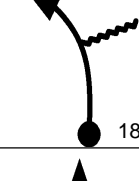
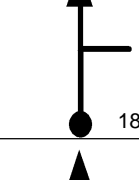
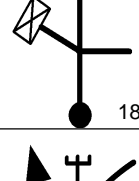
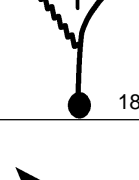
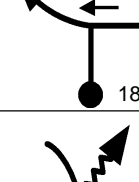
10 DE MARÇO 2018		Pág: 019	
4.12		39	01.06.01
	V	T61	
4.28		39	
	V	T61	
EROSÕES			
4.83		33	01.07.07
	V	T62	
4.88		21	01.07.12
	V	T63	
SUBA			
4.92		18	01.07.19
	V	T64	
4.95		15	01.07.25
	V	T65	
4.97		21	01.07.30
	V	T66	
5.06		23	01.07.45
	V	T67	
5.09		23	
	V	T67	
5.11		23	
	V	T67	

10 DE MARÇO 2018		Pág: 020	
ATOLEIRO			
PELA ESQUERDA			
5.23		23	
	V	T67	
	4'	01.08.40	
5.41		N	T68
			
5.41		39	01.12.40
	V	T69	
5.67		39	
	V	T69	
6.28		39	
	V	T69	
6.61		39	
	V	T69	
	21	01.15.09	
7.02		21	
	V	T70	
7.07		21	
	V	T70	
7.18		21	
	V	T70	

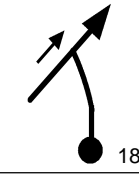
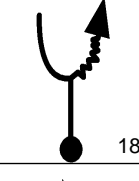
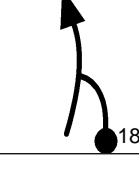
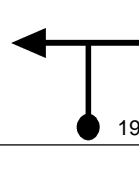
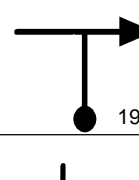
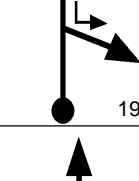
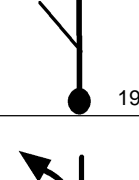
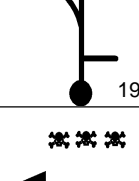
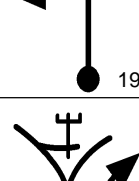
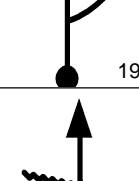
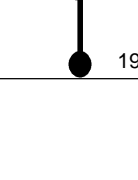
10 DE MARÇO 2018		Pág: 021	
7.22		21	
	V	T70	
7.34		21	
	V	T70	
7.43		21	
	V	T70	
	36	01.16.31	
7.50		36	
	V	T71	
7.53		36	
	V	T71	
7.61		36	
	V	T71	
7.69		21	01.17.06
	V	T71	
7.85		21	01.17.06
	V	T72	
	33	01.17.23	
7.95		33	
	V	T73	
8.02		33	
	V	T73	
8.08		33	
	V	T73	

10 DE MARÇO 2018		Pág: 022	
8.10		33	V T73
BUMP			
8.13		33	V T73
SUBA			
8.18		33	V T73
8.24		33	V T73
8.41		30s 01.18.13	N T74
8.41		39 01.20.43	V T75
8.68		39	V T75
9.87		39	V T75
9.94		39	V T75
10.18		39	V T75

10 DE MARÇO 2018		Pág: 023	
APOIO			
FIM DA 1ª ETAPA			
10.26		22' 01.23.34	N T76
10.26		15 01.45.34	V T77
0.00			V T77
INÍCIO DA 2ª ETAPA			
ZERE NO POSTE			
APÓS ASFALTO			
0.00		15	V T77
0.03		42	V T78
0.32		42	V T78
0.46		42	V T78
0.50		42	V T78
0.83		42	V T78
1.25		42	V T78

10 DE MARÇO 2018		Pág: 024	
1.37		42	V T78
1.42		42	V T78
1.75		39 01.48.09	V T79
2.06		39	V T79
2.08		36 01.48.51	V T79
2.21		36	V T80
2.25		36	V T80
2.35		2' 01.49.12	V T80
2.42		36 01.51.12	N T81
2.42		36	V T82
2.50		36	V T82

10 DE MARÇO 2018		Pág: 025	
2.56		36	
	228 V T82		
2.71		36	
	229 V T82		
3.01		36	
	230 V T82		
VILA SRF			
3.38		36	
	231 V T82		
3.48		36	
	232 V T82		
INICIO DESLOCAMENTO			
3.65		4' 01.53.15	
	233 D T83		
FIM DESLOCAMENTO			
4.06		39 01.57.15	
	234 V T84		
4.72		39	
	235 V T84		
4.73		36 01.58.17	
	236 V T85		
CUIDADO COM OS PÉS TRILHA COM TOCOS			





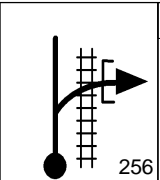
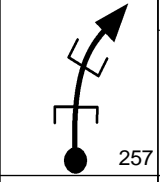
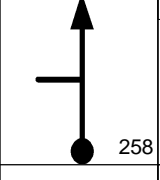
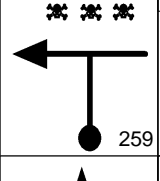
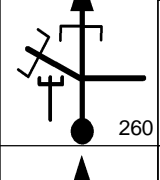
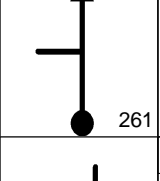
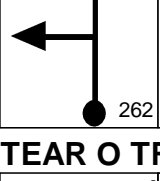
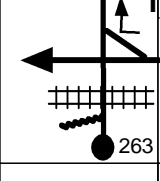
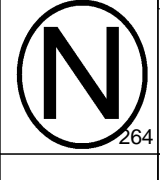
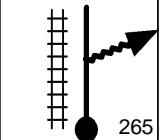

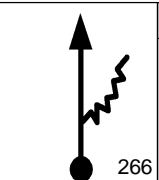
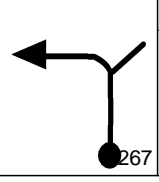
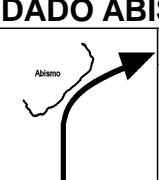
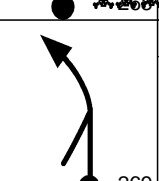
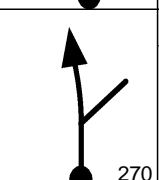
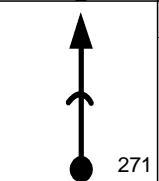
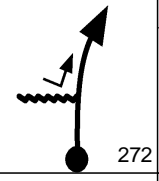
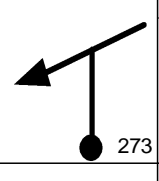
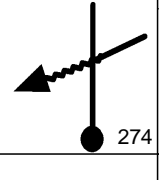
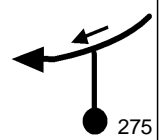
10 DE MARÇO 2018		Pág: 026	
4.76		36	
	237 V T85		
PIRITA			
SIGA BUMP			
5.06		30 01.58.50	
	238 V T86		
PELA MARGEM ESQUERDA			
5.17		30	
	239 V T86		
5.23		30	
	240 V T86		
5.37		33 01.59.27	
	241 V T87		
5.57		3' 01.59.49	
	242 N T88		
5.57		36 02.02.49	
	243 V T89		
COSTEAR TRILHO			
5.62		36	
	244 V T89		

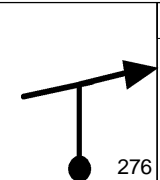
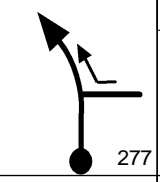
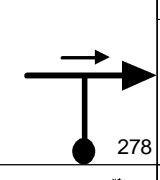
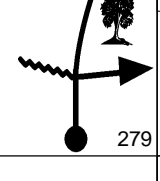
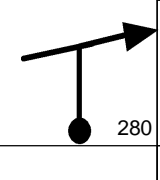
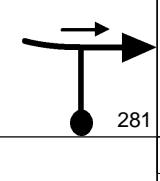
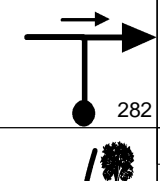
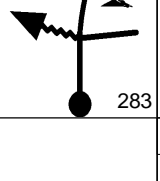
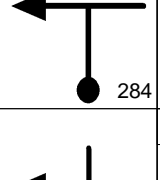
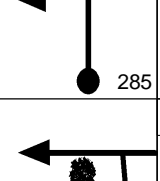
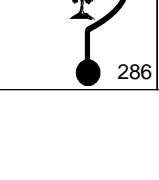

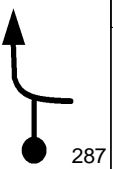
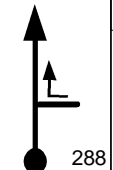

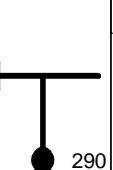
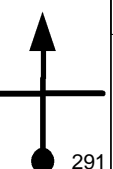
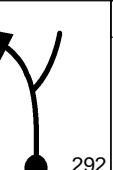
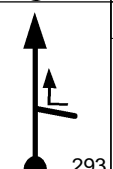

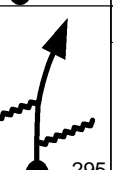

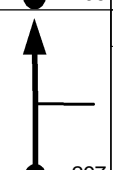
10 DE MARÇO 2018		Pág: 027	
5.80		36	
	245 V T89		
6.05		1' 02.03.37	
	246 N T90		
6.05		27 02.04.37	
0.00		27	
	247 V T91		
0.11		27	
	248 V T91		
0.40		27	
	249 V T91		
0.43		39 02.05.45	
	250 V T91		
0.51		39	
	251 V T92		
0.56		39	
	252 V T92		
0.68		39	
	253 V T92		
0.73		39	
	254 V T92		
0.91		39	
	255 V T92		

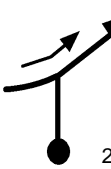

10 DE MARÇO 2018		Pág: 028	
1.27		39	V T92
1.57		39	V T92
1.68		39	V T92
2.08		39 02.08.10	V T93
2.11		39	V T93
2.48		39	V T93
2.66		39	V T93
COSTEAR O TRILHO			
2.99		30 02.09.34	N T94
2.99		36 02.11.04	V T95
3.19		21 02.11.24	V T96

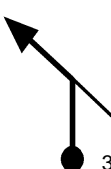



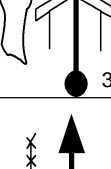

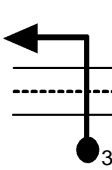
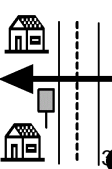
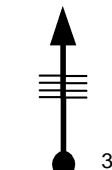
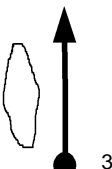
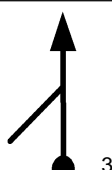
10 DE MARÇO 2018		Pág: 029	
3.20		21	V T96
3.30		30 02.11.43	V T97
CUIDADO ABISMO			
3.41		30	V T97
3.44		33 02.12.00	V T98
3.87		33	V T98
3.99		33	V T98
4.01		33	V T98
4.09		33	V T98
4.17		21 02.13.19	V T99
4.20		33 02.13.24	V T100

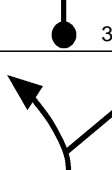
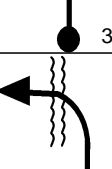

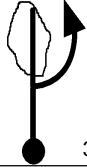
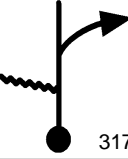
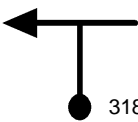

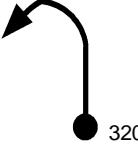
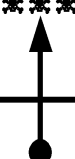
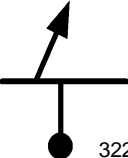

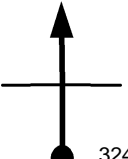
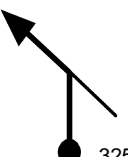
10 DE MARÇO 2018		Pág: 030	
4.28		33	V T100
4.34		33	V T100
4.46		33 02.13.53	V T101
4.49		33	V T101
4.61		33	V T101
4.65		33	V T101
4.78		33	V T101
4.81		27 02.14.31	V T102
4.86		33 02.14.38	V T103
4.95		21 02.14.47	V T104
4.98		21	V T104



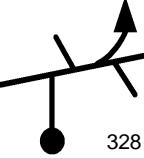

10 DE MARÇO 2018		Pág: 031	
5.00		21	V T104
5.03		27 02.15.01	V T105
5.07		27	V T105
5.11		33 02.15.12	V T106
5.20		33	V T106
5.27		27 02.15.38	V T106
5.35		27	V T107
5.45		27	V T107
5.54		27	V T107
5.65		27	V T107
5.75		18 02.16.31	V T108

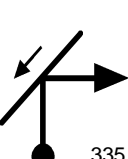
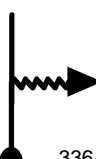

10 DE MARÇO 2018		Pág: 032	
5.83		27 02.16.47	V T109
5.93		27	V T109
			
6.02		27	V T109
6.12		27	V T109
6.20		2' 02.17.37	N T110
6.20		27 02.19.37	V T111
MUITO DEVAGAR			
RESPEITE A PROPRIEDADE			
6.24		21 02.19.42	V T112
6.60		18 02.20.44	V T113
NÃO ANDE NA BRITA			
VA PELA MARGEM ESQUERDA			

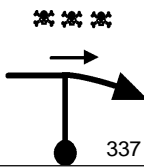

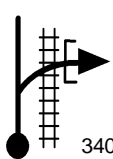

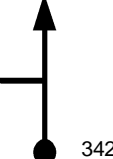
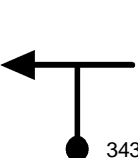
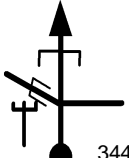
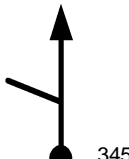
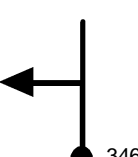
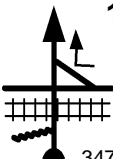

10 DE MARÇO 2018		Pág: 033	
6.84		18	V T113
6.98		39 02.22.00	V T114
7.73		39	V T114
7.76		18 02.23.12	V T115
7.87		18	V T115
7.93		18	V T115
DEVAGAR			
8.07		18	V T115
8.11		42 02.24.22	V T116
8.34		42	V T116
8.79		30 02.25.20	V T117

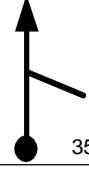
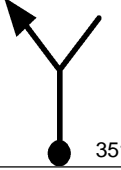
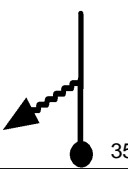
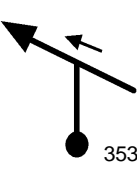
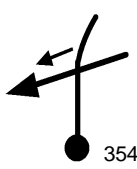
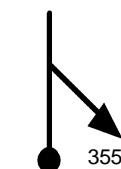
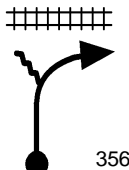
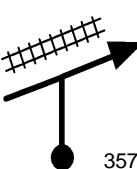
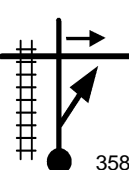

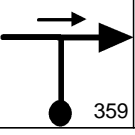



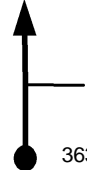
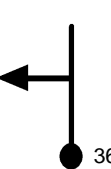
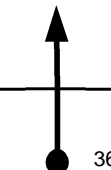

10 DE MARÇO 2018		Pág: 034	
8.88		30	V T117
9.10		30	V T117
9.17		30	V T117
9.23		30	V T117
9.42		30	V T117
9.56		30	V T117
9.58		36 02.26.55	V T118
9.60		36	V T118
9.62		36	V T118
9.67		36	V T118
9.70		36	V T118

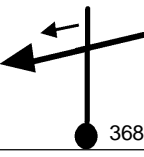
10 DE MARÇO 2018		Pág: 035	
9.79		36	V T118
9.86		42 02.27.23	V T119
10.12		42	V T119
10.19		42	V T119
10.27		42	V T119
10.98		42	V T119
11.02		42	V T119
11.29		39 02.29.25	V T120
11.43		27 02.29.38	V T121
CUIDADO COM OS PÉS			
TOCOS NA TRILHA			
11.51		15 02.29.49	V T122

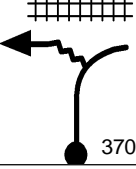
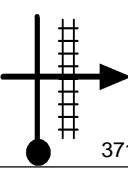
10 DE MARÇO 2018		Pág: 036	
11.63		39 02.30.18	V T123
11.78		3' 02.30.32	N T124
0.00		39 02.33.32	V T125
0.35		39	V T125
0.65		39	V T125
0.75		39	V T125
1.16		39	V T125
1.19		39	V T125
1.55		39	V T125
1.73		1'30s 02.36.42	V T125
2.06			N T126

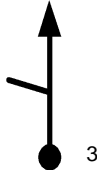
10 DE MARÇO 2018		Pág: 037	
2.06		36	02.38.12
		V	T127
2.28		36	
		V	T127
2.29		36	
		V	T127
2.34		36	
		V	T127
2.45		36	
		V	T127
2.53		36	
		V	T127
2.70		36	
		V	T127
2.71		27	02.39.17
		V	T128
2.87		27	
		V	T128
2.92		33	02.39.45
		V	T129
2.95		36	02.39.48
		V	T130

10 DE MARÇO 2018		Pág: 038	
2.97		36	
		V	T130
			
3.16		36	
		V	T130
3.17		36	
		V	T130
3.22		36	
		V	T130
3.28		36	
		V	T130
3.45		36	
		V	T130
3.51		36	
		V	T130
3.57		36	
		V	T130
3.67		36	
		V	T130

10 DE MARÇO 2018		Pág: 039	
3.85		36	
		V	T130
3.86		27	02.41.19
		V	T131
4.02		36	02.41.40
		V	T132
4.85		4'	02.43.03
		N	T133
4.85		21	02.47.03
		V	T134
4.94		30	02.49.50
		V	T134
5.82		30	
		V	T135
6.04		30	
		V	T135
PELO ACOSTAMENTO			
6.45		1'	02.51.05
		N	T136
PELO ACOSTAMENTO			
6.45		39	02.52.05
0.00		V	T137

10 DE MARÇO 2018		Pág: 040	
TRILHA DO MELA TANGA			
0.31		30	02.52.34
		V	T138
CUIDADO COM ATOLEIROS			
0.37		30	
		V	T138
ATOLEIRO			
VÁ PELA ESQUERDA			
0.44		30	
		V	T138
0.51		30	
		V	T138
0.58		30	
		V	T138
0.97		30	
		V	T138
PELA ESQUERDA			
1.04		30	
		V	T138
1.12		30	
		V	T138
ATOLEIRO			
PELA DIREITA			
1.19		24	02.54.19
		V	T139

10 DE MARÇO 2018		Pág: 041	
1.45		24	
		V	T139
1.50		24	
		V	T139
1.53		24	
		V	T139
1.62		39	02.55.24
		V	T140
1.68		39	
		V	T140
1.71		39	02.55.32
		V	T141
NOVA BELUNO			
1.93		39	
		V	T141
2.12		39	
		V	T141
2.73		39	
		V	T141
3.38		39	
		V	T141

10 DE MARÇO 2018		Pág: 042	
3.95		30	02.58.59
		V	T142
4.42		30	
		V	T142
4.58		30	
		V	T142
4.63		30	
		V	T142
4.66		30	
		V	T142
4.75		39	03.00.35
		V	T143
4.81		39	
		V	T143
4.84		3'	03.00.43
		N	T144
4.84		39	03.03.43
		V	T145
NOVA BELUNO			
5.06		39	
		V	T145

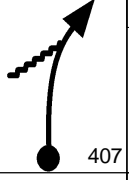
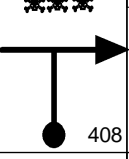
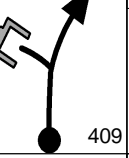
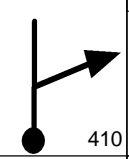
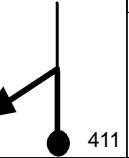
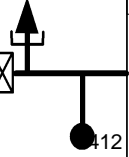
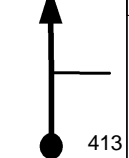
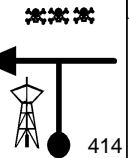
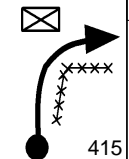
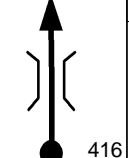
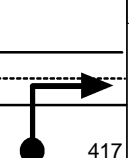
10 DE MARÇO 2018		Pág: 043	
5.25		39	
		V	T145
5.86		39	
		V	T145
7.00		39	
		V	T145
7.19		39	
		V	T145
7.70		39	
		V	T145
8.84		36	03.09.52
		V	T146
9.08		36	
		V	T146
9.48		33	03.10.56
		V	T147
10.26		33	
		V	T147
10.48		33	
		V	T147
11.59		33	
		V	T147

10 DE MARÇO 2018		Pág: 044	
11.65		33	
		V	T147
11.69		33	03.14.58
		V	T147
FIM DE PROVA !!			
			
www.t15.com.br			
A EQUIPE TRILHEIROS DO CARVÃO AGRADECE A SUA PRESENÇA EM NOSSA PROVA!!			
ATÉ A PRÓXIMA			
www.trilheirosdocarvao.com.br			
Tempo de Prova			
MÉDIA A 03:14:58			
FIM			