



# INICIO

## Estreantes

ENDURO LUA CHEIA  
LUA CHEIA

## IMPORTANTE

☠ CUIDADO

☠☠ ATENÇÃO

☠☠☠ MUITA ATENÇÃO

## Tempo de Prova

Estreantes 11:11:27



## AFERIÇÃO

INICIO AFERIÇÃO

0.00

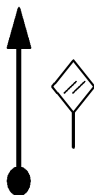

0.00

AFER

1

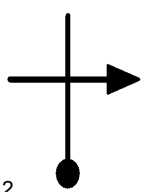
0.05	

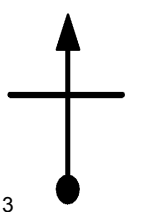
0.12	

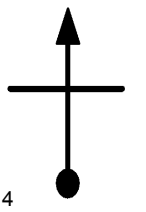
0.17	

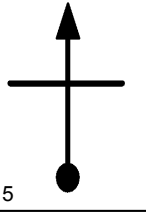
0.37	

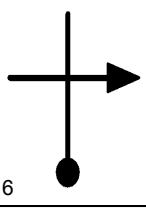
0.57	

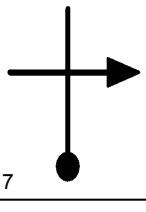
0.64	

0.76	
	8

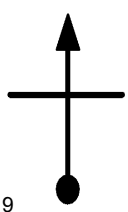
0.83	
	9

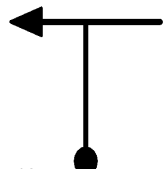
1.03	
	10

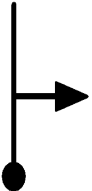
1.07	
	11

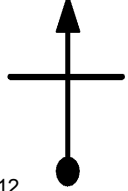
1.14	
	12

FIM AFERIÇÃO

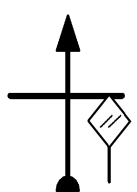
1.21	
	13



**INICIO DE PROVA**

<b>INICIO DE PROVA</b>	
<b>0.00</b>	
<b>0.00</b>	
V 21 0.00.00	
<b>T1</b>	14

<b>0.05</b>	
	15

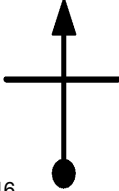
<b>0.13</b>	
	16

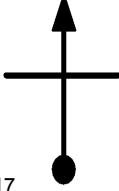
<b>0.21</b>	
	17

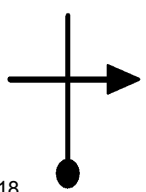
0.29	
	18

**ATENÇÃO AO CRUZAR**

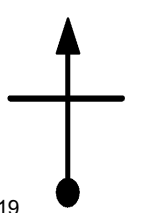
0.45	
	19

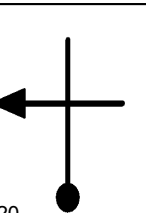
0.59	
	20

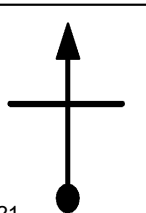
0.66	
	21

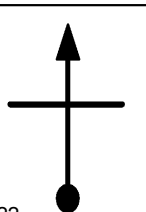
0.74	
	22

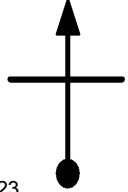
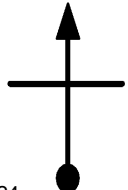
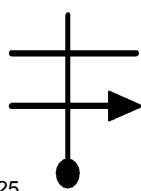
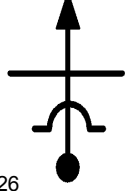
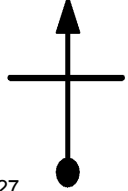
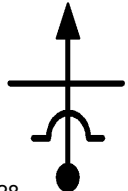
<p>0.81</p>	 <p>23</p>
<p>0.89</p>	 <p>24</p>
<p>0.96</p> <p>V 33 0.02.45</p> <p><b>T2</b></p>	 <p>25</p>
<p>1.14</p>	 <p>26</p>
<p>1.44</p>	 <p>27</p>
<p>1.50</p>	 <p>28</p>

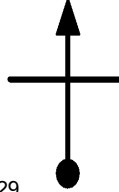
1.68	
	29

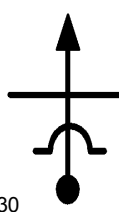
1.85	
	30

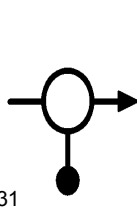
2.05	
	31

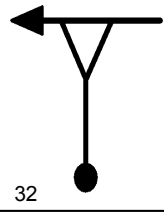
2.53	
	32

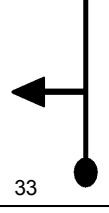
2.74	
	33

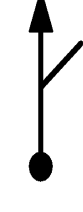
2.82	
<b>0.00</b>	
V 30 0.06.08	
<b>T3</b>	34



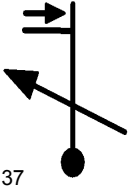

0.05	
	35

0.12	
	36

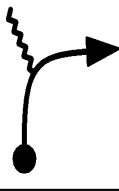
0.24	
	37

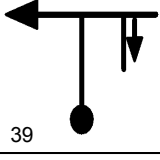
0.41	
	38

0.60	
	39

0.62	
	40

0.77	
	41

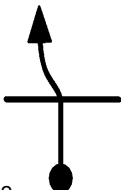
0.81	
	42

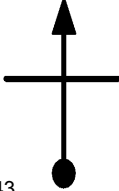
0.90	
	43

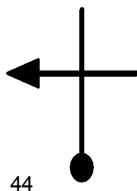
1.00	
	44

1.11	
	45

1.24	
	46

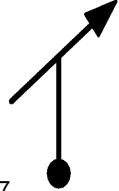
1.34	
	47

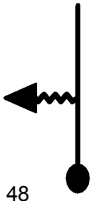
1.37	
	48

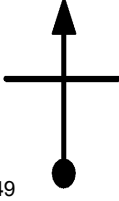
1.46	
	49

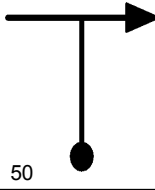
1.65	
	50

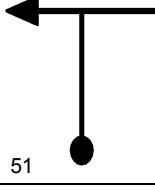
1.81	
	51

1.88	
	52

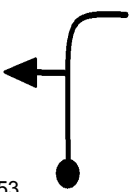
1.94	
	53

**CUIDADO GERAL**

2.22	Neutro
N 2' 0.10.35	
<b>T4</b>	54

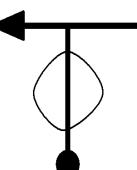
2.22	
V 45 0.12.35	
<b>T5</b>	55

2.87	
V 39 0.13.27	
<b>T6</b>	56

2.94	
	57

3.37	
	58

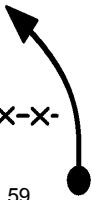
3.54	
V 36 0.14.29	59
<b>T7</b>	



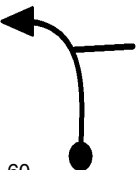

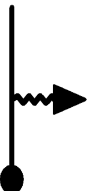
3.73	
	60

3.87	
	61

4.15	
	62

4.20	Neutro
N 2' 0.15.35	
<b>T8</b>	63

4.20	
V 42 0.17.35	
<b>T9</b>	64

4.37	
	65

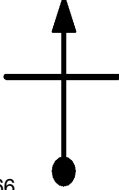
4.52	
	66

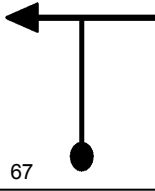
4.64	
	67

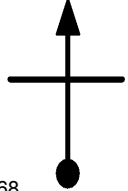
4.77	
	68

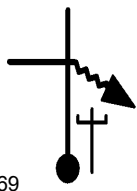
4.91	
V 39 0.18.36 <b>T10</b>	69

5.09	
	70

**CUIDADO GERAL**

5.69	Neutro
N 1' 0.19.48 <b>T11</b>	71

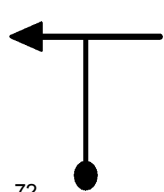
5.69	
V 39 0.20.48 <b>T12</b>	72

6.07	
	73

6.54	
	74

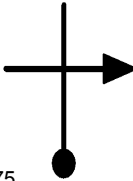
6.65	
	75

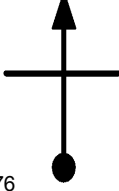
6.73	
	76

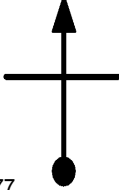
6.80	
	77

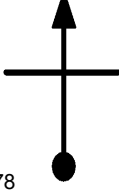
6.87	
	78

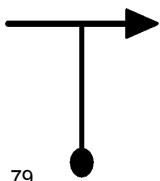

7.01	
	79

**SUBA ACELERE!!**

7.57	
V 33 0.23.41	80
<b>T13</b>	

7.70	
	81

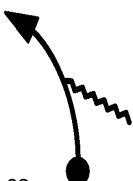
8.04	
	82

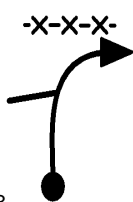
8.08	
	83

<p>8.25</p>	 <p>84</p>
-------------	--

<p>8.28</p>	 <p>85</p>
-------------	---

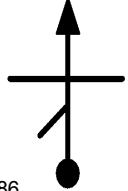
<p>8.64</p>	 <p>86</p>
-------------	---

**CUIDADO VALO**

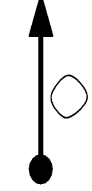
<p>9.03</p>	 <p>87</p>
-------------	--

<p>9.23</p>	<p><b>Neutro</b></p>
<p>N 3' 0.26.42</p>	<p>88</p>
<p><b>T14</b></p>	

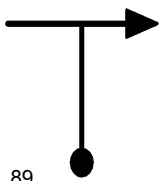
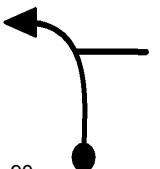
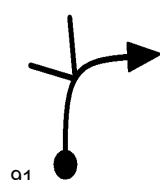
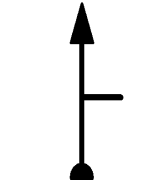
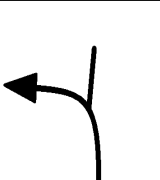
<p>9.23</p>	
<p>V 42 0.29.42</p>	<p>89</p>
<p>T15</p>	
<p>9.51</p>	
<p></p>	<p>90</p>
<p>9.72</p>	
<p></p>	<p>91</p>
<p>9.97</p>	
<p></p>	<p>92</p>
<p>10.42</p>	
<p>0.00</p>	<p>93</p>
<p>V 42 0.31.25</p>	<p>T16</p>

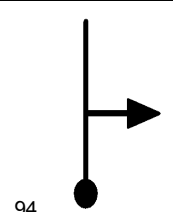
0.78	
	94

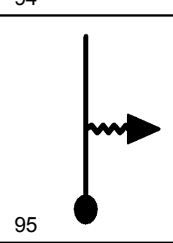
1.17	
V 39 0.33.05 T17	95

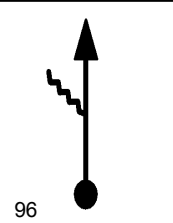
1.25	
	96

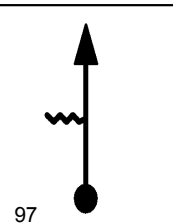
1.72	
	97

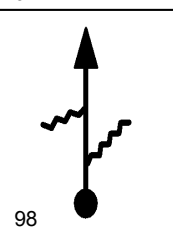
1.97	
	98

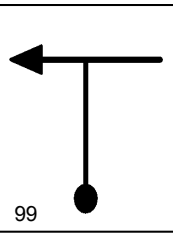
2.10	
	99

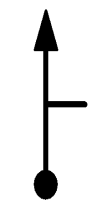
2.19	
	100

**EROSOES**

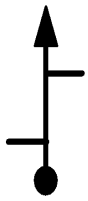
2.26	
V 24 0.34.46	101
<b>T18</b>	

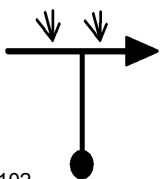
2.35	
	102

2.45	
	103

**NO MATO DESÇA**

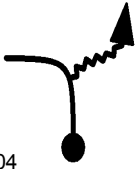
2.50	
	104

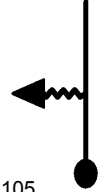
2.77	
	105

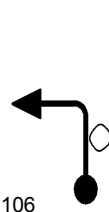
2.83	
	106

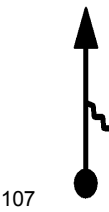
2.92	
	107

3.02	
	108

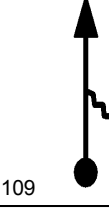
3.11	
	109

3.15	
	110

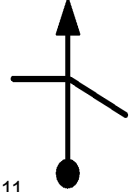
3.18	
V 30 0.37.04	
<b>T19</b>	111

**COSTEAR ROÇA**

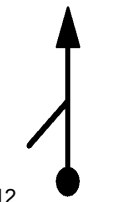
3.35	
	112

**ATENÇÃO**

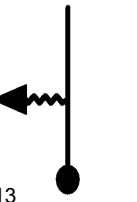
3.48	
	113

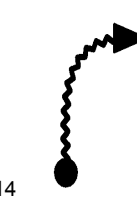
3.51	
	114

**ATENÇÃO**

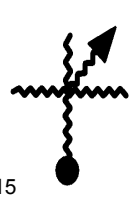
3.80	
	115

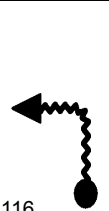
3.88	
	116

NA CANA

3.96	
	117

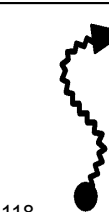
3.98	
	118

4.00	
	119

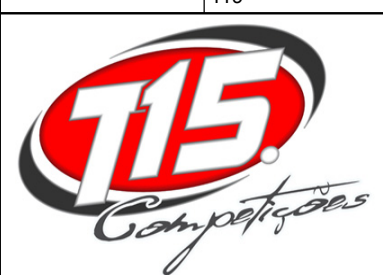

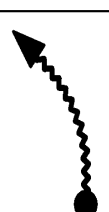
4.03	
	120

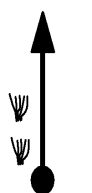

4.07	
	121

4.16	
	122

4.22	
	123

**CUIDADO GERAL**

4.27	<b>Neutro</b>
N 2' 0.39.15	
<b>T20</b>	124

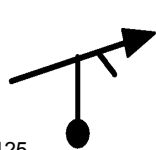
4.27	
V 42 0.41.15	
<b>T21</b>	125

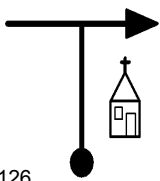
4.77	
	126

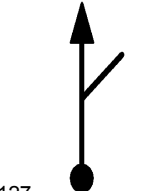
5.28	
	127

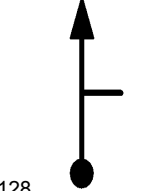
5.85	
	128

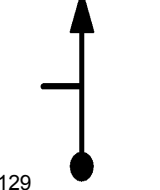
6.22	
	129

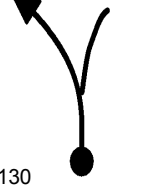
6.54	
	130

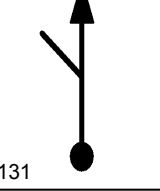
6.82	
	131

7.99

132

8.27

133

8.72

V 36 0.47.36

**T22**

134

8.80

135

8.91

136

9.04

-x-x-x-x-

137

9.07	
	138



9.14	
	139

9.24	
	140

9.41	Neutro
NI '30s 0.48.45	
<b>T23</b>	141

9.41	
V 42 0.50.15	
<b>T24</b>	142

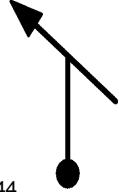
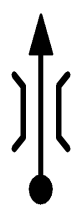
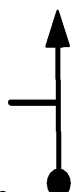
9.51	
	143

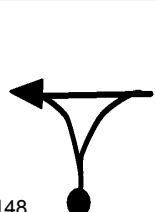
<p>9.54</p>	 <p>144</p>
<p>9.93</p> <p><b>0.00</b></p> <p>V 42 0.51.00</p> <p><b>T25</b></p>	 <p>145</p>
<p>0.12</p>	 <p>146</p>
<p>1.24</p>	 <p>147</p>
<p>1.83</p>	 <p>148</p>

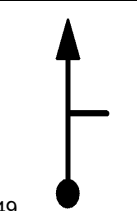
2.66	
	149

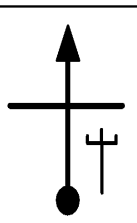
3.65	
<b>0.00</b>	
V 42 0.56.13	
<b>T26</b>	150

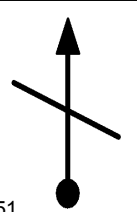
0.71	
	151

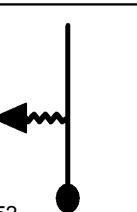
0.89	
V 42 0.57.29	
<b>T27</b>	152

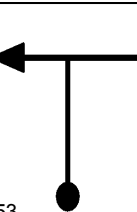
1.26	
	153

1.32	
	154

NO MATO

1.41	
V 39 0.58.13	
<b>T28</b>	155

1.59	
	156

1.71	
	157

2.25	
	158

2.29	
	159

2.41	
	160

2.45	
	161

2.48	
	162

**TOCO ESCONDIDO**

2.55	
	163

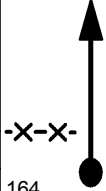

2.59	
	164

2.62	
	165

2.63	
	166

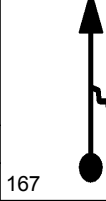
2.77	
	167

2.82	
	168

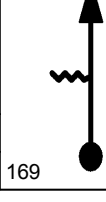
2.83	
	169

2.91	
	170

3.29	
	171

**GERAL CUIDADO**

3.43	Neutro
N2'30s 1.01.20 <b>T29</b>	172

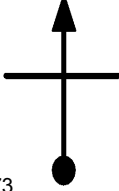
3.43	
V 42 1.03.50 <b>T30</b>	173

3.56	
	174

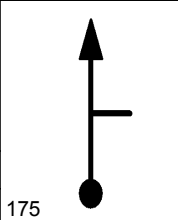
3.68	
	175

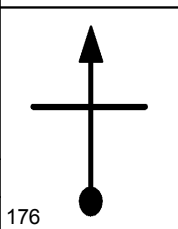
3.72	
	176

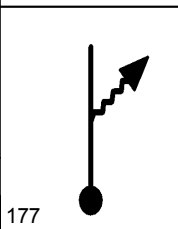
3.76	
V 39 1.04.18	177
<b>T31</b>	

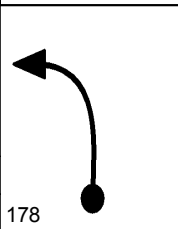
3.80	
	178

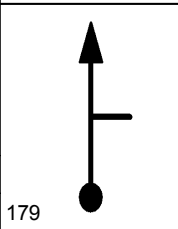
3.84	
	179

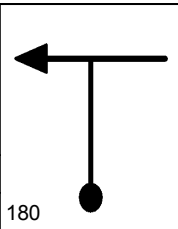

3.96	
	180

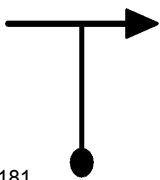
4.01	
V 42 1.04.41	
<b>T32</b>	181

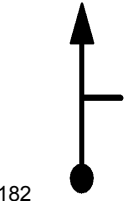
4.10	
	182

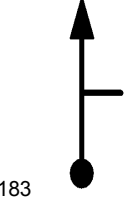
4.16	
	183

4.27	
	184

4.86	Neutro
N 2' 1.05.54	
<b>T33</b>	185

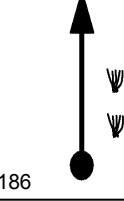
4.86	
V 27 1.07.54	
<b>T34</b>	186

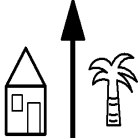
4.98	
	187

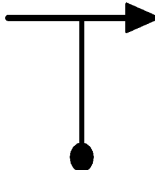
5.09	
<b>0.00</b>	
V 42 1.08.25	
<b>T35</b>	188

0.60	
	189

CUIDADO AO ATRAVESSAR!!!

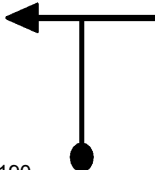
1.39	
	190

1.41	
	191

1.75	
	192

1.98	
	193

2.22	
	194

2.54	
	195

2.99	
	196

3.38	
V 45 1.13.15	
<b>T36</b>	197

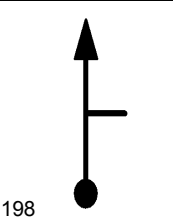
4.74	
	198

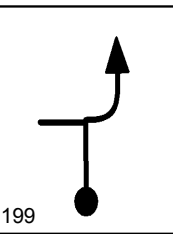
4.90	
	199

**CUIDADO MOTOS**

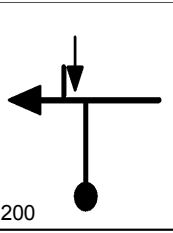
5.21	
V 39 1.15.41	
<b>T37</b>	200

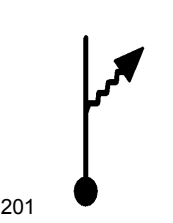
5.39	
	201

5.43	
	202

5.71	
	203

NO MATO

5.78	
	204

5.84	
	205

6.15	
	206

6.18	
	207

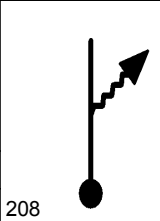

6.36	
	208

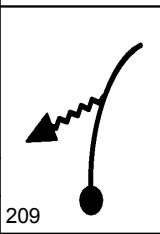
6.40	
	209

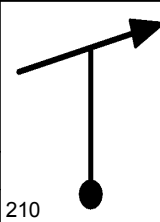
6.44	
	210

**CUIDADO MOTOS**

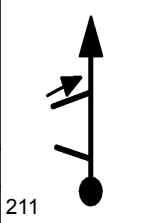
6.46	
	211

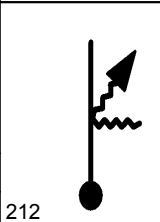
6.50	
	212

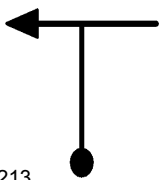
6.66	
	213

**CUIDADO MOTOS**

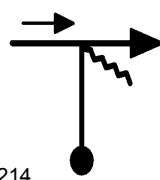
6.70	
	214

**CUIDADO MOTOS**

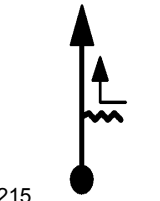
6.80	
	215

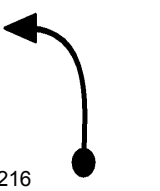
7.21	
	216

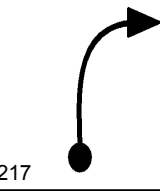
7.23	
	217

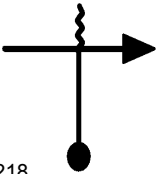
7.47	
	218

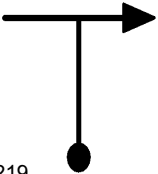
7.56	
	219

8.08	
	220

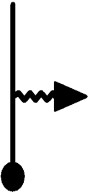
8.20	
	221

**CUIDADO MOTOS**

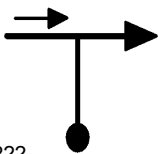
8.27	
	222

8.68	
	223

8.70	
	224

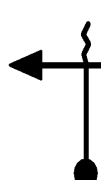
8.93	
	225

9.04	
	226

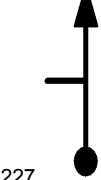
9.08	
	227

9.30	
	228

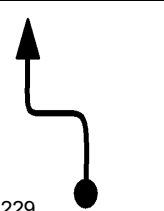
9.40	
	229

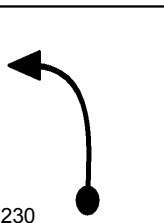
9.44	
V 45 1.22.12	
<b>T38</b>	230

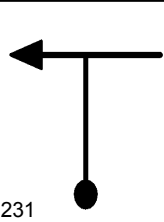
9.50	
V 39 1.22.16	
<b>T39</b>	231

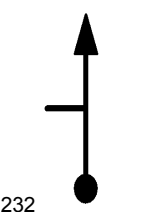
9.85	
	232

**CUIDADO MOTOS**

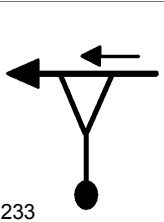
10.58	
V 36 1.23.56	
<b>T40</b>	233

10.61	
	234

<b>CUIDADO MOTOS</b>	
10.75	
	235

<b>CUIDADO MOTOS</b>	
10.85	
	236

11.27	
	237

11.29	
	238





11.52	
239	



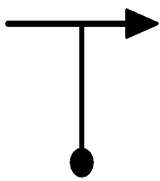

11.61	
240	

12.40	
N 3' 1.26.58	
<b>T41</b> 241	

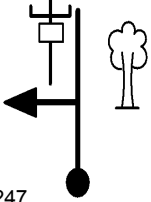
12.40	Neutro
V 27 1.29.58	
<b>T42</b> 242	

12.62	
<b>0.00</b>	
V 42 1.30.27	
<b>T43</b>	243
0.60	
	244
0.88	
	245
1.58	
	246
2.34	
V 33 1.33.48	
<b>T44</b>	247



2.42		
	248	

2.82		
	249	

3.17		
V 27 1.35.19		
<b>T45</b>	250	

**CUIDADO PONTE**

3.30		
	251	

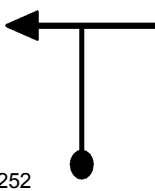
3.32		
	252	

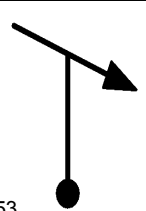
3.50	
	253

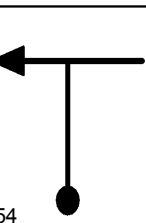
3.56	
	254

3.90	Neutro
N 1' 1.36.56	
<b>T46</b>	255

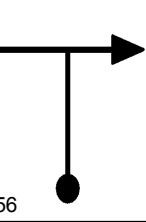
3.90	
V 33 1.37.56	
<b>T47</b>	256

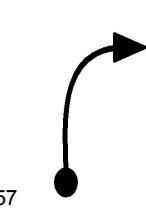
4.14	
	257

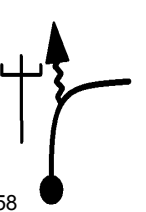
4.44	
	258

CUIDADO VALOS

4.55

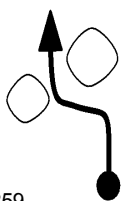

259

4.69

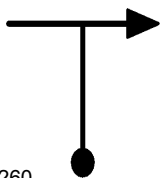

260

4.96



261

5.03



262

5.68

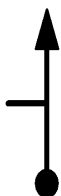

263

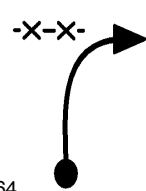
5.79	-x-x- 
	264

6.46	Neutro
NI'30s 1.42.35	
<b>T48</b>	265

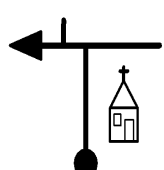
6.46	
V 42 1.44.05	
<b>T49</b>	266

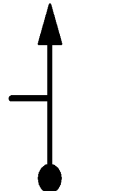
7.09	
	267

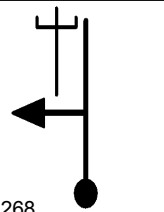
8.58	
V 36 1.47.07	
<b>T50</b>	268

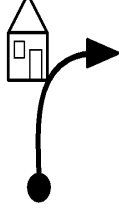
9.20	
	269

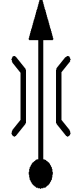
9.25	
	270

9.35	
V 42 1.48.24	
<b>T51</b>	271

9.63	
	272

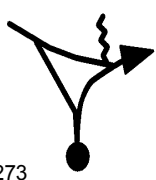
10.71	
	273

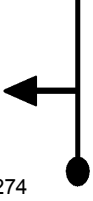
10.87	
	274

11.31	
V 33 1.51.12	
<b>T52</b>	275

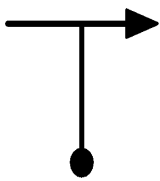
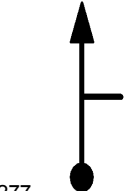
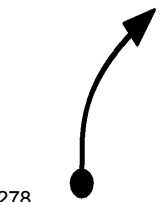
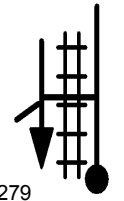
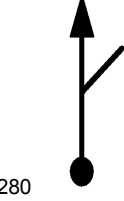
11.96	
<b>0.00</b>	
V 42 1.52.23	
<b>T53</b>	276
0.29	
	277
0.67	
	278
0.79	
	279
0.87	
	280

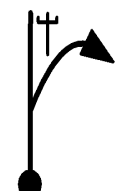
1.04	
	281

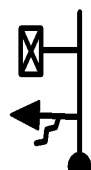
1.65	
V 27 1.54.45	
<b>T54</b>	282





1.81	
	283

**SUBIDA COM EROSIÃO**

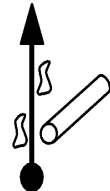
1.91	
V 30 1.55.20	
<b>T55</b>	284

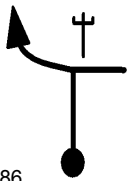
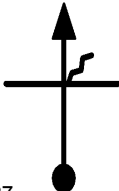
**DESCIDA COM EROSIÃO**

2.12	
	285

<p>2.50</p> <p>V 39 1.56.30</p> <p><b>T56</b></p>	 <p>286</p>
<p>3.15</p>	 <p>287</p>
<p>3.30</p> <p>V 36 1.57.45</p> <p><b>T57</b></p>	 <p>288</p>
<p>3.37</p>	 <p>289</p>
<p>3.58</p>	 <p>290</p>
<p>3.79</p>	 <p>291</p>



3.93	
V 18 1.58.48	

**T58** 292

**ATENÇÃO**

4.00	
	293

4.12	
	294

4.16	
	295

4.24	
	296

SUBIDA COM EROÇÃO

4.34



297

4.67

Neutro

N 4' 2.01.14

**T59**

298

4.67

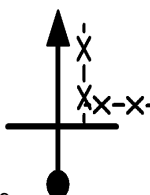

V 36 2.05.14

**T60**

299



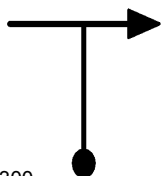

4.96

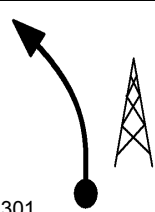

300

5.81	
	301

6.44	
	302

6.58	
	303

**CUIDADO GERAL**

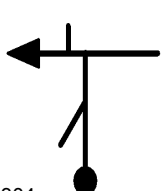
7.10	
	304

7.21	
	305

1º APOIO SANGÃO

7.30 Neutro

N 20' 2.09.37

T61 306

7.30

0.00

V 42 2.29.37

T62 307

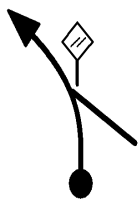

0.80

308

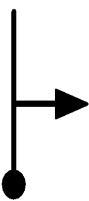

1.03

309





1.13

V 36 2.31.14

T63 310

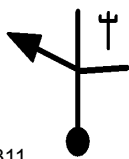



1.25	
	311

1.34	
	312

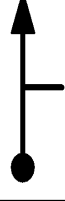
2.18	
V 33 2.33.00	313
<b>T64</b>	

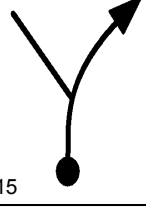
2.61	
	314

2.84	
	315

2.89	
	316

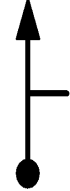
3.28	
	317

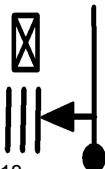
3.90	
	318

4.14	
	319

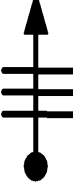
4.30	
	320

4.46	
	321

**PELO MEIO DA ROÇA**

4.71	
	322

VALO

4.75

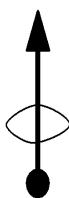

323

5.13

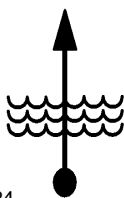

324

5.22

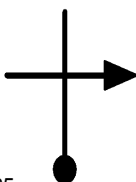

V 36 2.38.31

**T65**

325

5.76

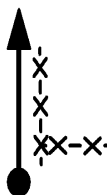

326

CUIDADO GERAL





6.05

Neutro

N2'30s 2.39.54

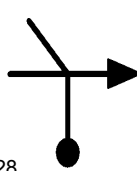
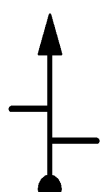
**T66**

327

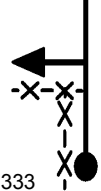
<p>6.05</p> <p>V 39 2.42.24</p> <p><b>T67</b></p>	 <p>328</p>
<p>6.41</p>	 <p>329</p>
<p>7.34</p>	 <p>330</p>
<p>7.46</p>	 <p>331</p>
<p>7.96</p>	 <p>332</p>
<p>8.10</p>	 <p>333</p>

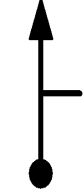

8.47	
	334

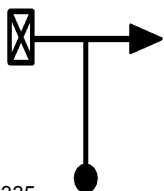
8.63	
V 33 2.46.22	
<b>T68</b>	335

8.81	
	336

**EROSÃO**

9.02	
	337

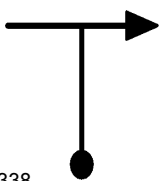
9.17	
	338

9.31	
	339

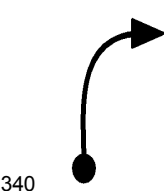
9.37	
	340

9.40	
	341

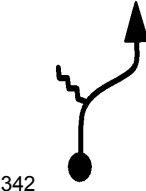
9.43	
	342

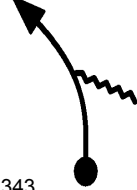
9.72	
	343

9.91	Neutro
N 2' 2.48.41	
<b>T69</b>	344

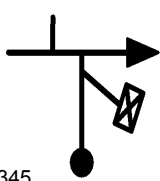
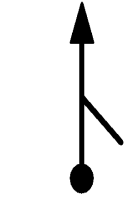
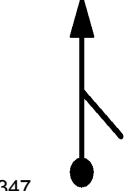
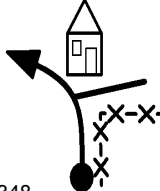
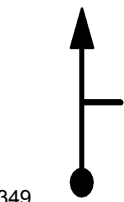
<p>9.91</p> <p>V 39 2.50.41</p> <p><b>T70</b></p>	 <p>345</p>
<p>10.27</p> <p><b>0.00</b></p> <p>V 39 2.51.15</p> <p><b>T71</b></p>	 <p>346</p>
<p>0.12</p>	 <p>347</p>
<p>0.36</p>	 <p>348</p>
<p>0.57</p>	 <p>349</p>

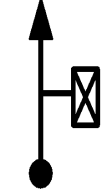
1.29	
	350

**GERAL CUIDADO!!!**

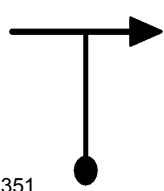
1.36	
	351

**ATENÇÃO AO CRUZAR!**

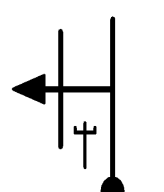
1.87	
V 33 2.54.08	
<b>T72</b>	352

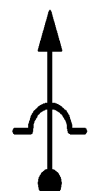
2.19	
	353

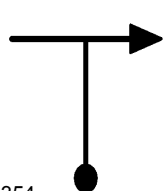
2.64	
	354

3.13	Neutro
N 30s 2.56.25	
<b>T73</b>	355

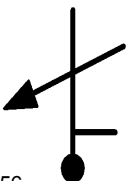
3.13	
V 42 2.56.55	
<b>T74</b>	356

3.35	
	357

3.89	
	358

4.30	
	359



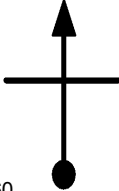

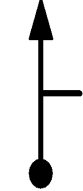
4.64	
	360

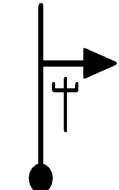
4.92	
	361

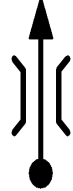
5.15	
V 33 2.59.48	
<b>T75</b>	362

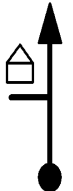
5.23	
	363

5.74	
	364

6.02	
	365

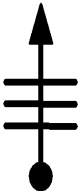
6.06	
	366

6.15	
	367

6.32	
V 36 3.01.57	
<b>T76</b>	368

6.39	
	369

6.43	
	370

6.75	
	371

7.05	
	372

7.25	
	373

7.40	
	374

7.54	
	375

ATENÇÃO!

7.61	
	376

NO MATO

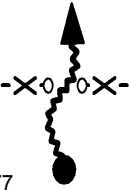
7.76	
V 18 3.04.20	
<b>T77</b>	377



CUIDADO ROÇA

8.11

V 33 3.05.31

T78

378

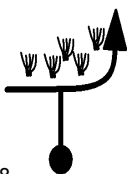

8.30

379



8.56

380

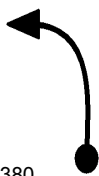

8.67

381

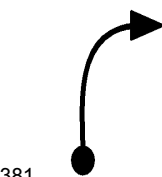

8.81

382

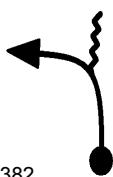

**CUIDADO VALO!!!**

8.98

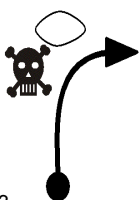

383

**CUIDADO GERAL**

9.42

Neutro

N 3' 3.07.54

**T79**

384

9.42



V 36 3.10.54

**T80**

385

10.18

**0.00**

V 33 3.12.10

**T81**

386

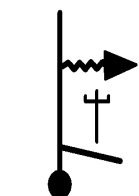

0.36

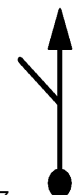

387

**CUIDADO PEDRAS**

0.47



388

**ATENÇÃO**

0.63



V 24 3.13.19

**T82**

389

**ATENÇÃO**

0.66



390

**ATENÇÃO**

0.81



391

**ATENÇÃO**

0.90

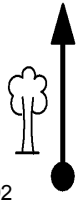

392

CUIDE DA ROÇA

0.99

V 30 3.14.13

**T83**

393

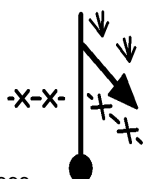

1.10

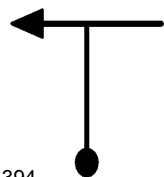

394

1.20



395

1.24

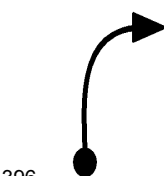

396

NO MATO

1.44

V 18 3.15.07

**T84**

397



ATENÇÃO

1.48

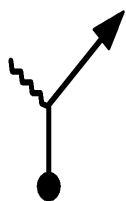

398

NO MATO

1.50



399

CUIDADO EROSÃO

1.63



400

2.21

V 30 3.17.40

**T85**



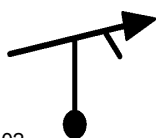

401

2.33



402

2.44	
	403

2.51	
	404

2.78	
	405

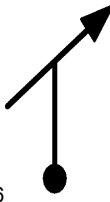
2.86	
	406

2.89	Neutro
N 2' 3.19.02	
<b>T86</b>	407

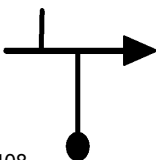
2.89	
V 36 3.21.02	
<b>T87</b>	408

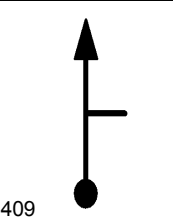
2.99	
	409

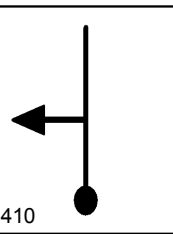
3.35	
	410

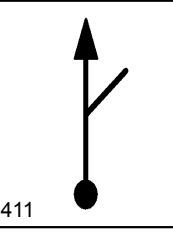
3.61	
	411

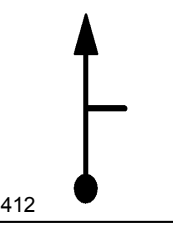
3.99	
	412

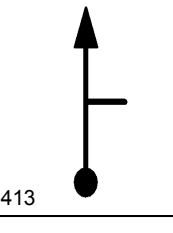
4.34	
	413

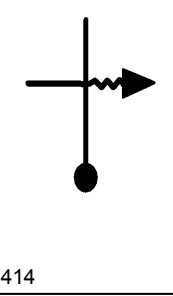
4.46	
<b>0.00</b>	
<b>V 36 3.23.39</b>	
<b>T88</b>	414

0.19	
	415

0.24	
	416

0.46	
	417

0.65	
V 24 3.24.45	
<b>T89</b>	418

1.18	
	419





1.41	
	420

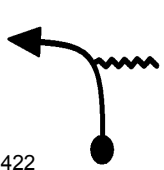

1.67	
	421

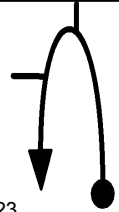
1.93	
V 33 3.27.57	
<b>T90</b>	422

2.14	
	423

2.41	
	424

2.74	Neutro
N 2' 3.29.25	
<b>T91</b>	425

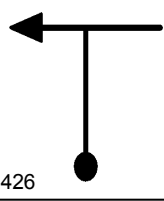
2.74	
V 36 3.31.25	
<b>T92</b>	426

2.89	
	427

3.59	
	428

3.63	
V 33 3.32.54	
<b>T93</b>	429

3.65	
	430

**ACELERA!!**

3.79	
	431

4.00	
V 30 3.33.35	
<b>T94</b>	432

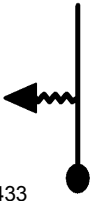
4.53	
V 21 3.34.38	
<b>T95</b>	433

5.26	
	434

5.43	
	435

5.80	
	436

**CURVA PERIGOSA!!**

6.02	
V 27 3.38.54	
<b>T96</b>	437

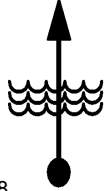
6.41	
	438

6.44	Neutro
N3'30s 3.39.51	
	<b>T97</b> 439

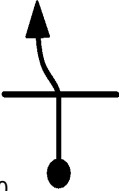
6.44	
V 27 3.43.21	
	<b>T98</b> 440

6.72	
	441

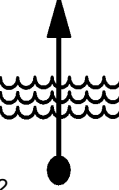
6.75	
	442

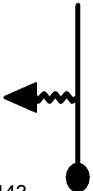
6.79	
	443

6.87	
	444

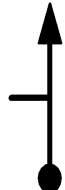
6.92	
	445

7.13	
	446

**BURACO PERIGO**

7.36	
	447

7.40	
	448

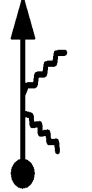
7.60	
	449

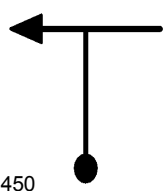
7.64	
	450

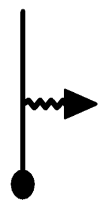
7.70	
	451

<b>TRAVADO</b>	
7.93	
V 21 3.46.38	
<b>T99</b>	452

8.04	
	453

8.05	
V 27 3.47.00	
<b>T100</b>	454

8.12	
	455

8.14	
	456

8.28	
	457

8.36	
	458

**SUBIDA COM EROSAO**

8.48	
	459

8.57	
	460

8.82	
	461

8.93	
	462

**EROSÕES A FRENTE**

9.00	
V 15 3.49.06	
<b>T101</b>	463

9.27	
V 24 3.50.12	
<b>T102</b>	464

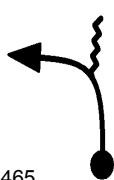

9.49	
	465

9.65	
	466

9.92	
V 21 3.51.49	
<b>T103</b>	467

PERIGO! SIGA PELA DIREITA

10.12	
	468

PELA DIREITA

10.15	
	469

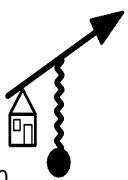
10.35	
	470

10.41	Neutro
N 3' 3.53.13	
<b>T104</b>	
	471

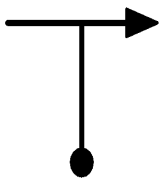
10.41	
<b>0.00</b>	
V 36 3.56.13	
	<b>T105</b>
	472

0.26	
	473

0.38	
	474

0.55	
	475

0.69	
	476

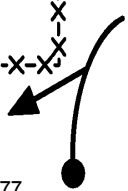
1.00	
V 33 3.57.53	
<b>T106</b>	477

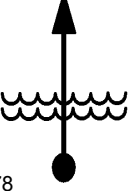
1.10	
	478

1.33	
	479



1.38	
	480

1.45	
V 27 3.58.42	
<b>T107</b>	481

**BAMP NO MATO**

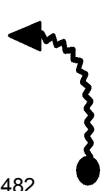
1.48	
	482

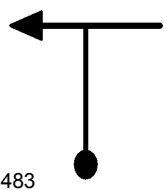
1.50	
	483

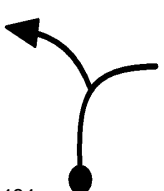
1.91	
	484

**CUIDADO TOCO**

2.02	
	485

2.42	
	486

2.59	
	487

**ATENÇÃO**

2.67	
	488

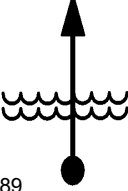
2.70	
	489

2.98	
	490

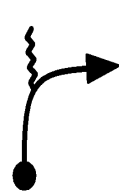
3.11	
	491

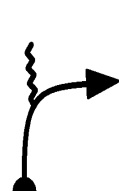

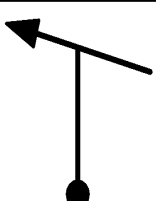

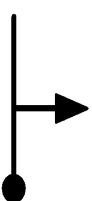
3.30	
	492

3.39	
	493

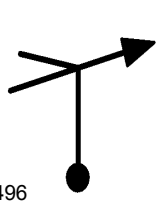
3.53	
	494

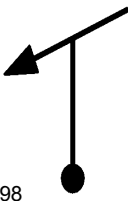
3.69	
	495

3.70	
	496

3.76	Neutro
N3'30s 4.03.50	
<b>T108</b>	497
3.76	
V 33 4.07.20	
<b>T109</b>	498
4.22	
V 39 4.08.11	
<b>T110</b>	499
4.62	
	500
4.92	
	501
5.25	
V 33 4.09.46	
<b>T111</b>	502

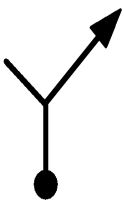
5.30	
	503

5.35	
	504

5.59	
	505

5.77	
V 27 4.10.43	
<b>T112</b>	506

SUBIDA COM EROSAO

5.95	
V 30 4.11.06	
<b>T113</b>	507

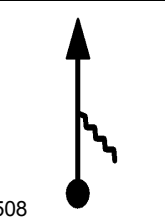

6.08	
	508

6.34	Neutro
N2'30s 4.11.53	
<b>T114</b>	509

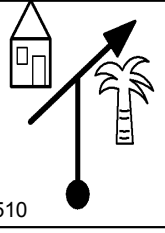
6.34	
V 36 4.14.23	
<b>T115</b>	510

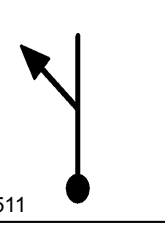
6.46	
	511

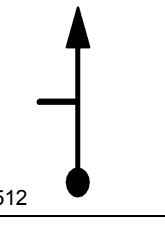
6.57	
	512

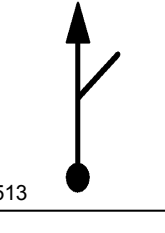
6.59	
	513

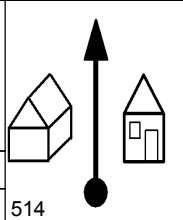
<p>6.83</p>	
	514

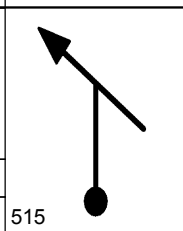
<p>7.28</p>	
	515

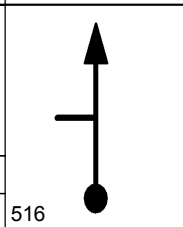
<p>7.62</p>	
	516

**CUIDADO GERAL**

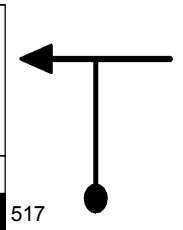
<p>9.03</p>	
V 42 4.18.52	
<b>T116</b>	517

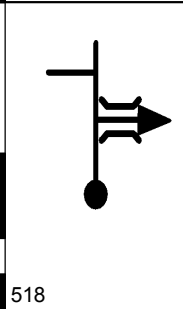
<p>9.26</p>	
<b>0.00</b>	
V 42 4.19.12	
<b>T117</b>	518

0.77	
	519

0.99	
	520

1.14	
	521

<b>PERIGO</b>	
1.25	
	522

2.15	
	523

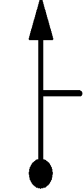
2.21	
	524

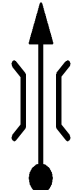
2.38	
	525

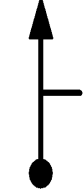
2.75	
	526

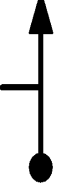
3.25	
	527

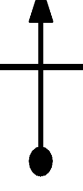
3.98	
	528

4.67	
	529

4.80	
	530

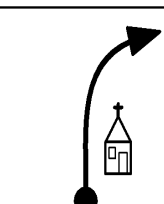
5.20	
	531

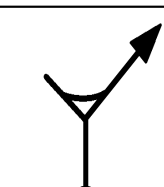
5.29	
	532

NÃO ERRE

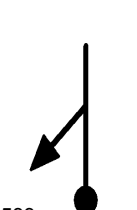
5.54	
V 33 4.27.07	
<b>T118</b>	533

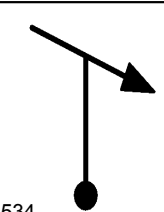
5.56	
	534

6.15

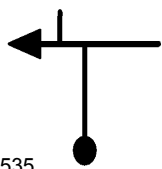

535

6.76



536

6.90

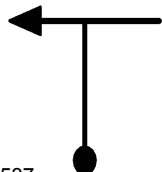

537

7.06



538

7.30

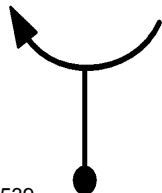

539



7.43

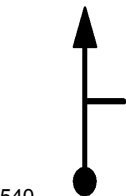

540

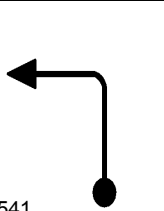
7.58	
	541

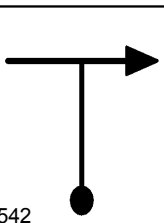
7.63	
	542

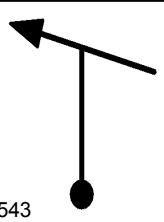
7.86	
V 27 4.31.20	
<b>T119</b>	543

**CUIDADO**

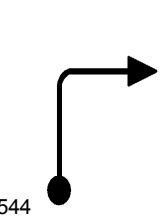
7.97	
	544

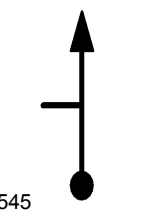
8.05	
	545

EROSOES

8.15	
	546

8.27	
	547

8.33	Neutro
N 3' 4.32.22	
<b>T120</b>	548

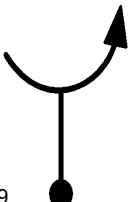
8.33	
V 27 4.35.22	
<b>T121</b>	549

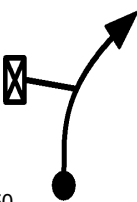
8.56	
	550



<p>8.62</p> <p><b>0.00</b></p> <p>V 36 4.36.02</p> <p><b>T122</b></p>	<p>551</p>
<p>0.17</p>	<p>552</p>
<p>0.55</p>	<p>553</p>
<p>0.79</p> <p>V 27 4.37.21</p> <p><b>T123</b></p>	<p>554</p>
<p>0.93</p>	<p>555</p>

1.02	
	556

1.39	
	557

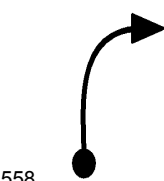
1.60	
	558

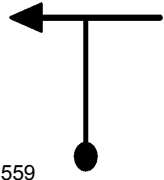
1.87	
	559

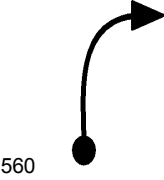
2.09	
	560

2.15	
	561

2.24 Neutro  
N2'30s 4.40.34  
T124 562

2.24  
V 27 4.43.04  
T125 563



2.39  
564

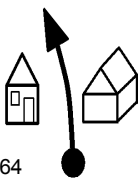

2.46  
V 42 4.43.33  
T126 565

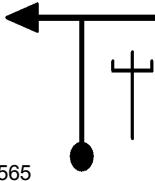

2.65  
566



3.08  
567

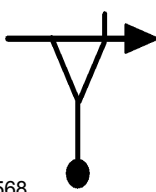

3.29 

568

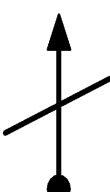
3.40 

569

3.61 

570

3.67 

571

3.86 

572

4.13 

V 30 4.45.57

**T127** 573

4.39	
	574

4.66	
	575

4.69	
	576

**ATENÇÃO NO COQUEIRO**

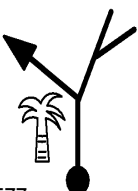
4.71	
V 18 4.47.07	
<b>T128</b>	577

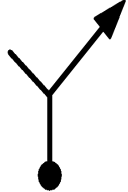
4.73	
	578

4.78	
	579

**EROSÕES A FRENTE**

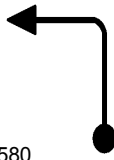
4.82	
	580

5.00	
	581

5.01	Neutro
N 3' 4.48.07	
<b>T129</b>	582

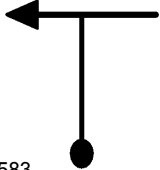
5.01	
V 30 4.51.07	
<b>T130</b>	583

5.25	
	584

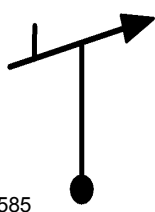
5.35	
V 27 4.51.47	
<b>T131</b>	585

5.55	
	586

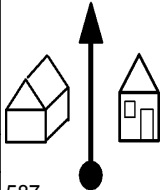
5.63	
	587

5.78	
	588

5.81	
	589

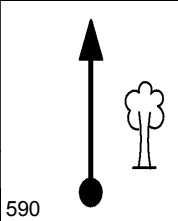
5.89	
V 30 4.52.59	
<b>T132</b>	590

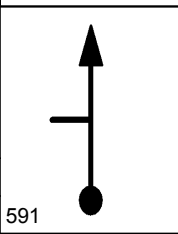
6.00	
	591

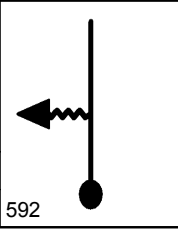
6.39	
	592

**ATENÇÃO**

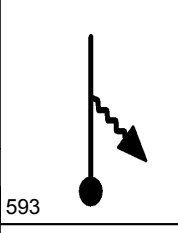
6.63	
V 21 4.54.27	
<b>T133</b>	593

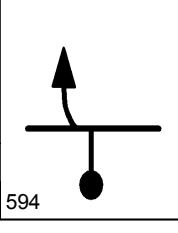
6.80	
V 27 4.54.56	
<b>T134</b>	594

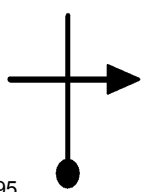

6.92	
	595

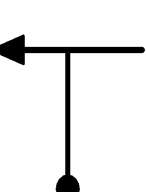
6.99	
	596

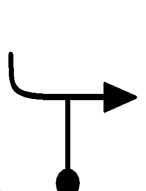
7.16	
	597

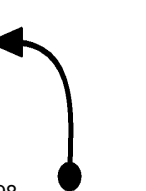
7.21	
	598

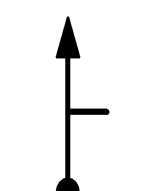
7.24	
	599

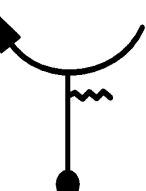

7.70	
	600

7.73	
	601

7.84	
	602

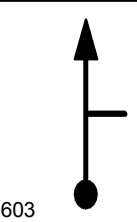
8.01	
	603

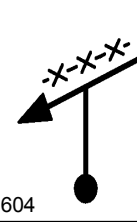
8.11	
V 33 4.57.51 T135	604

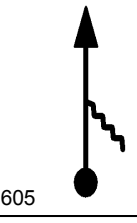
8.13	
	605

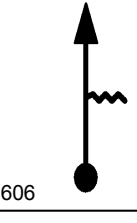
8.19	
	606

8.31	
	607

8.41	
	608



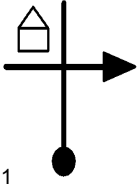

8.59	
	609

8.80	
	610

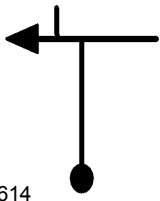
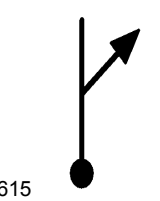
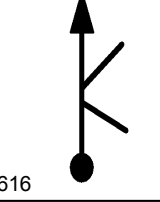
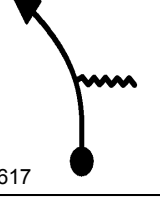
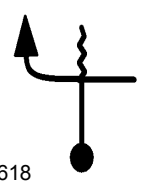
8.83	
V 30 4.59.10 T136	611

8.93	
	612

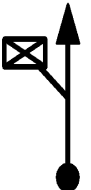
<p>9.23</p> <p>N 3' 4.59.58</p> <p><b>T137</b></p>	<p>Neutro</p> <p>613</p>
<p>9.23</p> <p>V 33 5.02.58</p> <p><b>T138</b></p>	 <p>614</p>
<p>9.49</p>	 <p>615</p>
<p>9.59</p>	 <p>616</p>
<p>9.77</p>	 <p>617</p>
<p>10.07</p>	 <p>618</p>

10.21	
V 24 5.04.45	
<b>T139</b>	619
10.65	
	620
10.75	Neutro
N2'30s 5.06.07	
<b>T140</b>	621
10.75	
<b>0.00</b>	
V 36 5.08.37	
<b>T141</b>	622
0.07	
	623

0.15	
	624

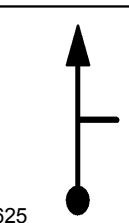

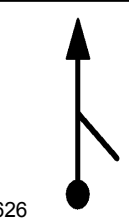

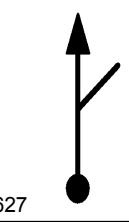
0.63	
	625

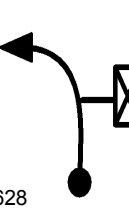
1.02	
	626

1.44	
	627

2.97	
V 39 5.13.34 T142	628

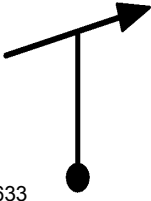
3.00	
	629

<p>3.48</p> <hr/> <hr/>	 <p>630</p>
<p>4.05</p> <hr/> <hr/>	 <p>631</p>
<p>4.52</p> <hr/> <hr/>	 <p>632</p>
<p>5.05</p> <hr/> <p>V 36 5.16.46</p> <p><b>T143</b></p>	 <p>633</p>
<p>5.27</p> <hr/> <hr/>	 <p>634</p>
<p>5.91</p> <hr/> <hr/>	 <p>635</p>

LOCALAMENTO DE PREFERENCIA

<p style="font-size: 2em; margin: 0;">5.96</p> <p style="margin: 0;">D 2' 5.18.18</p> <p style="background-color: black; color: white; padding: 2px; display: inline-block;"><b>T144</b></p>	 <p style="text-align: right; margin-top: 10px;">636</p>
--	--

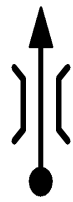
<p style="font-size: 2em; margin: 0;">6.14</p>	 <p style="text-align: right; margin-top: 10px;">637</p>
--	---

**2º APOIO URUSSANGA**

<p style="font-size: 2em; margin: 0;">6.25</p> <p style="margin: 0;">N 20' 5.20.18</p> <p style="background-color: black; color: white; padding: 2px; display: inline-block;"><b>T145</b></p>	<p style="font-size: 1.5em; margin: 0;">Neutro</p> <p style="text-align: right; margin-top: 10px;">638</p>
---	--

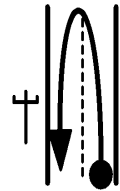
<p style="font-size: 2em; margin: 0;">6.25</p> <p style="background-color: black; color: white; padding: 5px; font-size: 1.5em; margin: 5px 0;">0.00</p> <p style="margin: 0;">V 42 5.40.18</p> <p style="background-color: black; color: white; padding: 2px; display: inline-block;"><b>T146</b></p>	 <p style="text-align: right; margin-top: 10px;">639</p>
--	--

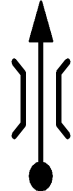
<p style="font-size: 2em; margin: 0;">0.08</p>	 <p style="text-align: right; margin-top: 10px;">640</p>
--	---



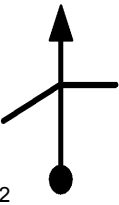

DE PREFERENCIA

0.20	
	641

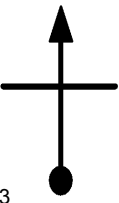
0.25	
	642

0.47	
	643

0.99	
	644

1.49	
	645

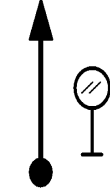
2.52	
	646

3.12	
	647

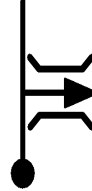
3.58	
	648

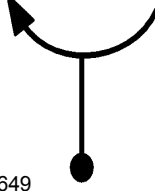
3.60	
	649

4.51	
	650

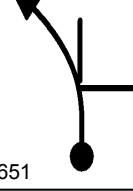
4.75	
	651

4.87	
V 36 5.47.16	
<b>T147</b>	652

5.02	
	653

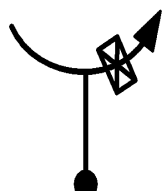
5.18	
	654

5.39	
V 30 5.48.08	
<b>T148</b>	655

**COSTEAR PELA DIREITA**

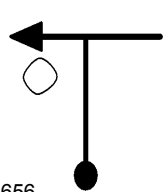
5.49	
	656

5.89	
	657

6.06	
	658

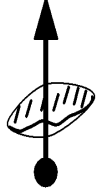
6.29	
	659

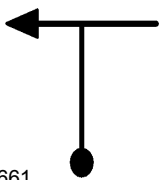

6.60	
	660

7.13	
	661

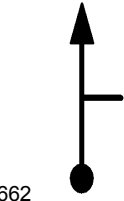
7.28	
	662

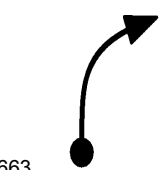
7.60	
	663

7.75	
	664

**NO EUCALIPTO**

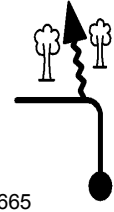
7.84	
	665

7.86	
	666

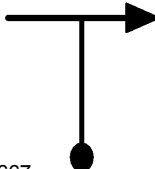
8.11	
	667

8.14	Neutro
N 2' 5.53.37	
<b>T149</b>	668

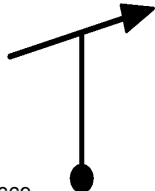
8.14	
V 36 5.55.37	
<b>T150</b>	669

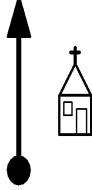
8.48	
	670

**ATENÇÃO**

8.54	
V 15 5.56.17	
<b>T151</b>	671

CUIDADO VALO

8.97

0.00

V 24 5.58.01

T152 672

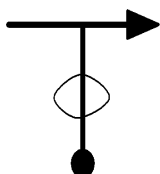

PELO LADO

0.12

673



0.19

674

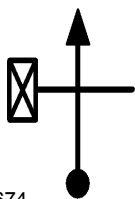

0.46

675

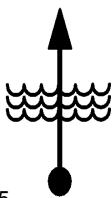

1.17

676

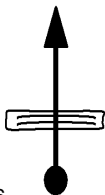

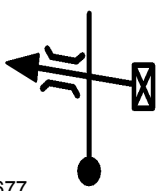
1.19	
	677

1.21	Neutro
N 2' 6.01.03	
<b>T153</b>	678

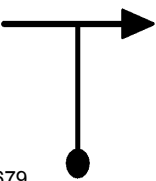
1.21	
V 36 6.03.03	
<b>T154</b>	679

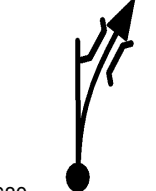
1.69	
	680

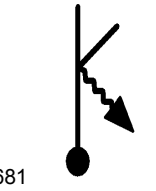
2.17	
V 33 6.04.39	
<b>T155</b>	681

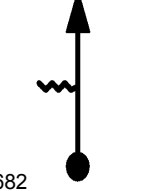
2.38	
	682





2.42	
	683

2.55	
	684

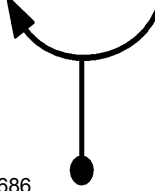
2.66	
V 27 6.05.32	
<b>T156</b>	685

<b>COSTEAR BARRANCO</b>	
2.70	
	686

<b>SUBA</b>	
2.76	
	687

2.83	
	688

**BURACO PERIGO**

2.92	
	689

3.28	
V 33 6.06.55	
<b>T157</b>	690

3.52	
	691

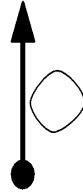
4.15	
	692

4.35

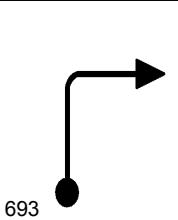

693

ABISMO A FRENTE

4.38



694

Neutro

N 2' 6.08.54

T158

4.38

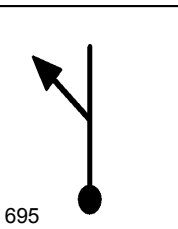

695

V 24 6.10.54

T159

4.50

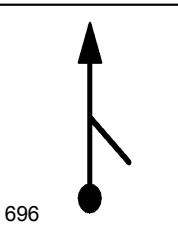

696

PERIGO ABISMO

4.55

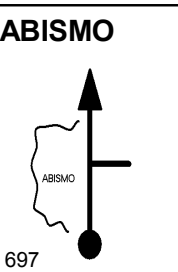

697

PERIGO

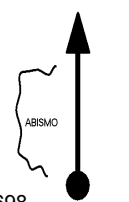
4.60	
	698

4.64	
V 30 6.11.34	
<b>T160</b>	699

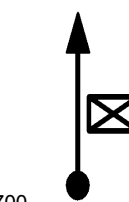
5.02	
	700

5.08	Neutro
N 2' 6.12.27	
<b>T161</b>	701

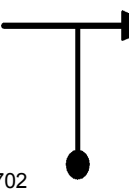
5.08	
V 42 6.14.27	
<b>T162</b>	702

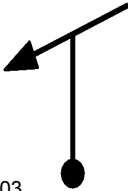
5.23	
	703

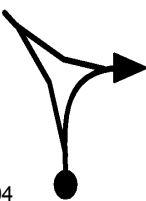
5.86	
	704

6.07	
V 33 6.15.51	
<b>T163</b>	705

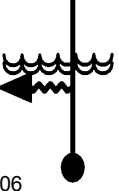
6.31	
	706

6.50	
	707

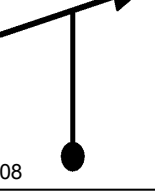
6.54	
	708

<p>6.68</p> <p>_____</p> <p>_____</p>	 <p>709</p>
---------------------------------------	---

<p>6.72</p> <p>_____</p> <p>_____</p>	 <p>710</p>
---------------------------------------	--

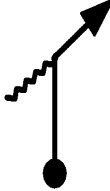
<p>6.75</p> <p>_____</p> <p>_____</p>	 <p>711</p>
---------------------------------------	--

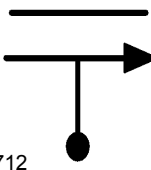
<p>7.00</p> <p>_____</p> <p>_____</p>	 <p>712</p>
---------------------------------------	---

<p>7.08</p> <p>_____</p> <p>_____</p>	 <p>713</p>
---------------------------------------	--

<p>7.11</p> <p>N 2' 6.17.45</p> <p><b>T164</b></p>	<p>Neutro</p> <p>714</p>
--	--------------------------

7.11	
V 42 6.19.45	
<b>T165</b>	715

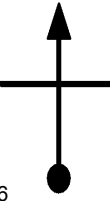
7.46	
	716

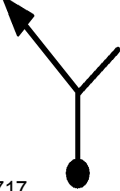
7.64	
	717

7.81	
	718

7.85	
	719





7.89	
	720

7.96	
	721

8.67	
<b>0.00</b>	
V 42 6.21.59	
<b>T166</b>	722

0.07	
	723

0.70	
	724

1.47	
	725

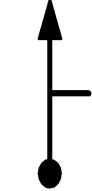

1.99	
	726

2.18	
V 27 6.25.06	
<b>T167</b>	727

2.23	
	728

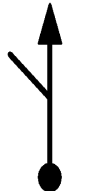
2.30	
	729

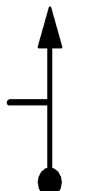
2.86	
	730

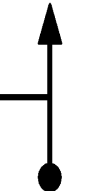
3.16	
	731

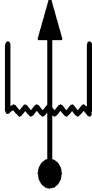
3.38	
V 39 6.27.46	
<b>T168</b>	732

3.70	
	733

4.10	
	734

**ATENÇÃO**

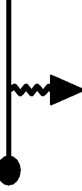
4.83	
V 27 6.30.00	
<b>T169</b>	735

5.27	
<b>0.00</b>	
V 27 6.30.58	
<b>T170</b>	736

PELA ESQUERDA

0.17

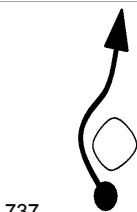

737

0.48

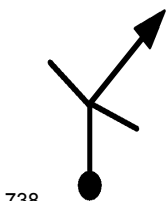

738

CURVA PERIGOSA

0.68

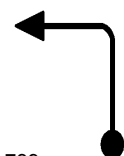

739

1.02



740

1.23

Neutro

N 2' 6.33.43

T171

741

1.23	
V 42 6.35.43	
<b>T172</b>	742

1.29	
	743

2.27	
<b>0.00</b>	
V 42 6.37.12	
<b>T173</b>	744

0.40	
	745

1.25	
	746

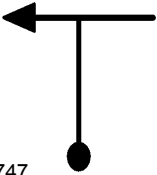
1.69	
	747

2.41	
	748

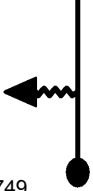
2.86	
V 27 6.41.17	
<b>T174</b>	749

2.95	
	750

**CUIDADO ARVORE**

3.19	
	751

DESCIDA PERIGOSA ABISMO

3.39	Neutro
N 2' 6.42.28	
<b>T175</b>	752

3.39	
V 15 6.44.28	
<b>T176</b>	753

ABISMO

3.60	
	754

3.95	
V 27 6.46.42	
<b>T177</b>	755

NAO ERRE

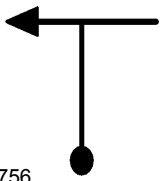
4.03	
	756

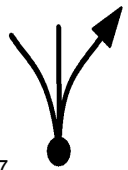
4.04	
	757

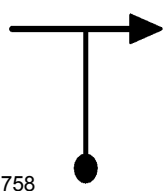
4.19	
	758

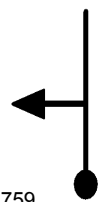
4.21	
V 24 6.47.17	
<b>T178</b>	759

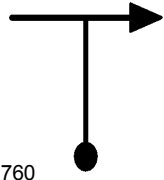
4.59	
	760

4.75	
	761

5.00	
	762

5.12	
	763

5.20	
	764





5.30	Neutro
N2'30s 6.50.00	
<b>T179</b>	765

5.30	
V 36 6.52.30	
<b>T180</b>	766

5.33	
	767

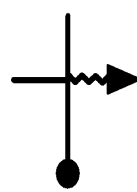
5.73	
V 30 6.53.13	
<b>T181</b>	768





5.88	
0.00	
V 30 6.53.31	
T182	769
0.20	
	770
0.39	
	771
0.42	
	772
0.51	
	773

0.73	
	774

0.86	Neutro
N 2' 6.55.15	
<b>T183</b>	775

0.86	
V 42 6.57.15	
<b>T184</b>	776

1.07	
	777

1.26	
	778

1.38	
	779



1.60	
	780

1.76	
V 24 6.58.32	
<b>T185</b>	781

1.82	
	782

1.89	
	783

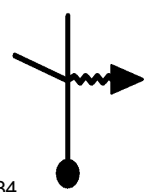
2.52	
	784

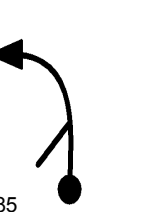
2.82	
	785

2.85	
	786

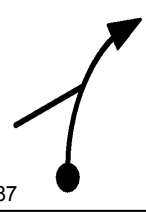
2.99	
	787

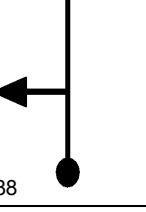
3.05	
	788

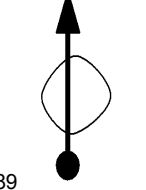
3.23	
V 30 7.02.12	
<b>T186</b>	789

3.36	
	790

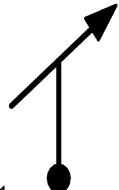
3.46	
	791

3.55	Neutro
N2'30s 7.02.51	
<b>T187</b>	792

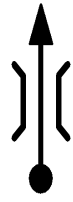
3.55	
V 27 7.05.21	
<b>T188</b>	793

3.87	
	794

3.94	
	795

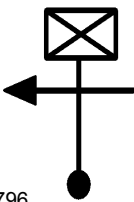
4.03	
V 39 7.06.25	
<b>T189</b>	796

4.07	
	797

4.38	
	798

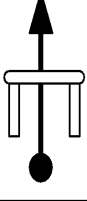
4.58	
	799

4.61	
V 30 7.07.19	
<b>T190</b>	800

4.69	
	801

<p>4.77</p>	 <p>802</p>
-------------	---

<p>4.89</p>	 <p>803</p>
-------------	--

<p>5.28</p>	 <p>804</p>
-------------	--

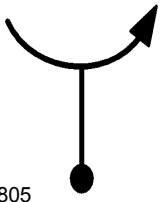
<p>5.53</p>	 <p>805</p>
-------------	---

<p>5.56</p>	<p>Neutro</p>
<p>N2'30s 7.09.12</p>	<p>806</p>
<p>T191</p>	

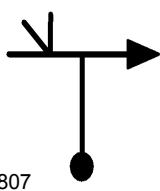
<p>5.56</p>	 <p>807</p>
<p>V 39 7.11.42</p>	
<p>T192</p>	

6.06	
	808

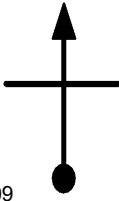
6.42	
	809

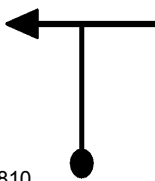
7.12	
V 42 7.14.06	
<b>T193</b>	810

7.93	
	811

8.58	
	812

8.91	
	813



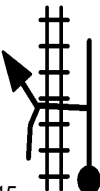

9.12	
	814

9.41	
	815

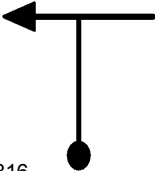
**EM DIREÇÃO A PONTE**

9.46	
	816

9.48	
	817

9.55	
	818

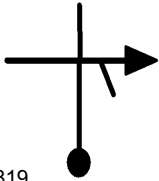
10.17	
	819

10.60	
	820

10.88	
	821

11.19	
	822

11.35	
	823

11.60	
	824

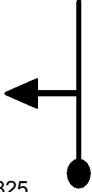
11.63	
	825

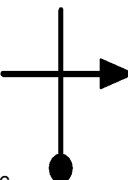
11.88	
	826

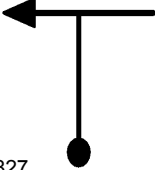
12.04	
	827

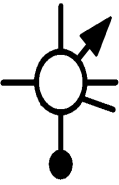
SAIA DO ASFALTO	
12.26	
<b>0.00</b>	
V 42 7.21.27	
<b>T194</b>	828

0.49	
	829

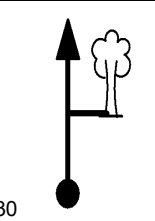
1.25	
	830

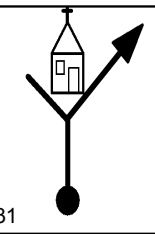
1.67	
	831

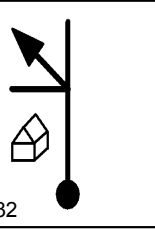
2.00	
V 33 7.24.18	
<b>T195</b>	832

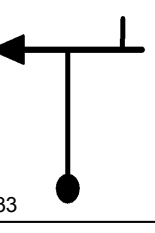
2.33	
V 36 7.24.54	
<b>T196</b>	833

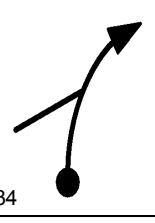
2.55	
	834

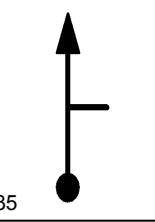
2.91	
	835

3.15	Neutro
N 1' 7.26.16	
<b>T197</b>	836

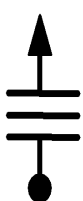
3.15	
V 27 7.27.16	
<b>T198</b>	837

**RESPEITE OS MORADORES**

3.35	
	838

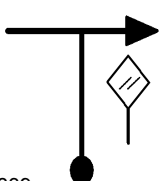
3.38	
V 42 7.27.48	
<b>T199</b>	839

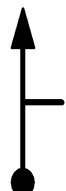

4.00	
	840

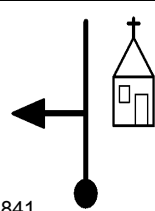
5.08	
	841

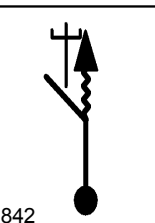
5.80	
V 33 7.31.15	
<b>T200</b>	842

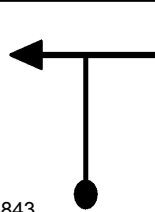
6.08	
	843

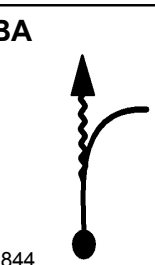
<b>SUBA</b>	
6.26	
V 39 7.32.05	
<b>T201</b>	844

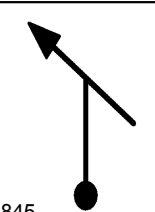
6.30	
	845

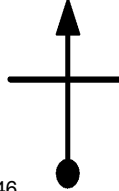
6.35 

846

6.61 

847

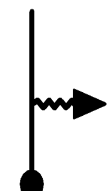
6.94 

V 33 7.33.08  
T202 848

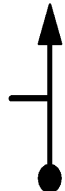
7.12 

849

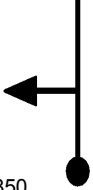
7.16 

850

7.30 

851

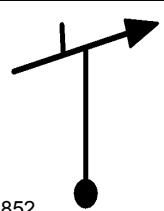
7.32	
	852

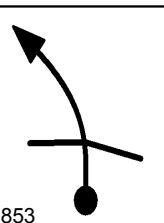
7.52	
	853

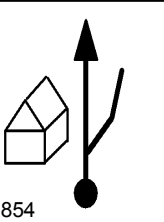
7.75	
	854

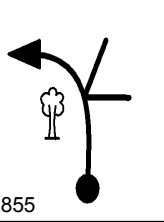
7.99	
	855

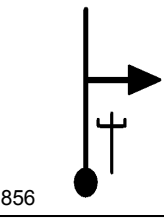
8.14	
	856

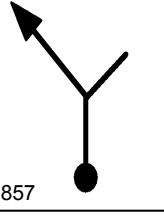
8.22	
	857

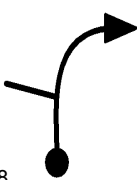

8.41	
	858

8.45	
	859

8.54	
	860

**ATENÇÃO**

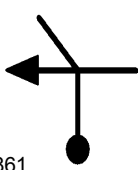
8.67	
	861

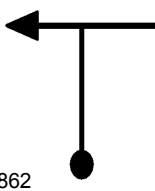
8.84	
	862

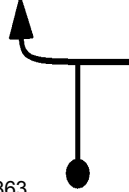
8.98	
	863

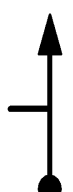
9.18	
	864

**ATENÇÃO**

9.33	
	865

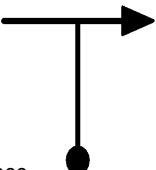
9.49	
	866

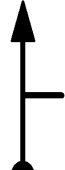
9.57	
	867

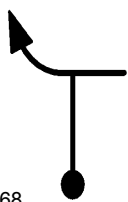
9.86	
V 27 7.38.26	
<b>T203</b>	868

9.93	
	869

**CUIDADO PEDRAS**

10.21	
	870

10.42	
V 33 7.39.41	
<b>T204</b>	871

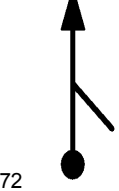
10.63	
	872

10.77	Neutro
N 3' 7.40.19	
	T205 873



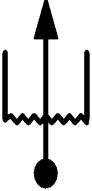

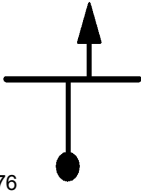
10.77	
V 39 7.43.19	
	T206 874

11.05	
	875

11.45	
	876

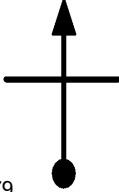
11.84	
	877

UNIDAD TREVO MOVIMENTADO	
11.94	
	878

<p>12.39</p>	 <p>879</p>
<p>12.66</p>	 <p>880</p>
<p>13.00</p>	 <p>881</p>
<p>13.32</p>	 <p>882</p>
<p>13.46</p> <p><b>0.00</b></p> <p>V 30 7.47.27</p> <p><b>T207</b></p>	 <p>883</p>

0.18	
	884

**ATENÇÃO!!! BAMP**

0.32	
	885

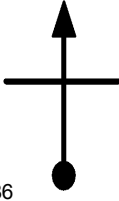
0.38	
	886

0.40	
	887

0.52	
	888

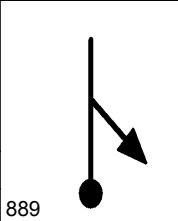
0.71	
	889

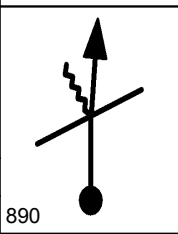
0.75	
	890

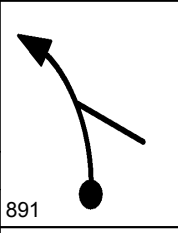
0.84	
	891

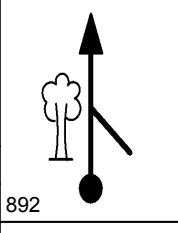
0.99	
	892

1.02	
	893

**ATENÇÃO**

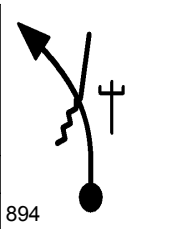
1.14	
	894

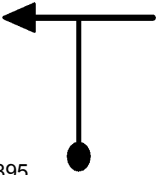
1.28	
	895

1.58	
	896

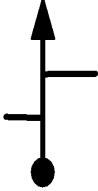
1.61	
	897

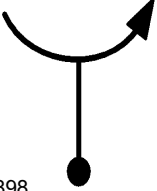
1.63	
	898

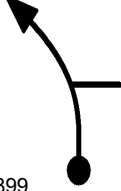
1.80	
	899

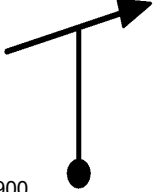

1.92	
	900



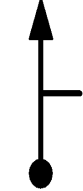

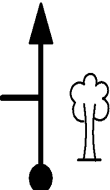
1.94	
	901

2.00	
	902

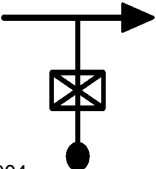
2.37	Neutro
N 4' 7.52.12	
<b>T208</b>	903

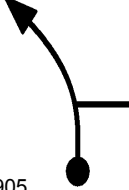
2.37	
V 39 7.56.12	
<b>T209</b>	904

2.55	
	905

2.93	
	906

RUA PERIGOSA CUIDADO!!!

3.44	
	907

3.88	
	908

4.43	
	909

4.76	
	910

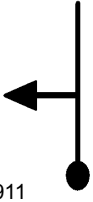
4.79	
V 30 7.59.55	
<b>T210</b>	911

4.81

\_\_\_\_\_

\_\_\_\_\_

912



4.82

\_\_\_\_\_

\_\_\_\_\_

913



5.16

\_\_\_\_\_

\_\_\_\_\_

914



5.73

\_\_\_\_\_

\_\_\_\_\_

915



5.78

\_\_\_\_\_

\_\_\_\_\_

916



5.79

\_\_\_\_\_

\_\_\_\_\_

917

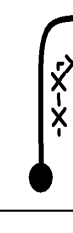

<b>5.91</b>	<b>Neutro</b>
N 2' 8.02.10	
<b>T211</b>	918

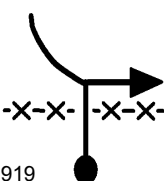

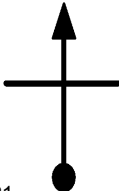

<b>5.91</b>	
V 36 8.04.10	
<b>T212</b>	919

<b>6.19</b>	
	920

<b>6.41</b>	
	921

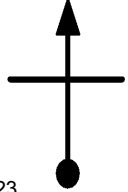
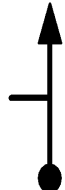
**CUIDADO RUA MOVIMENTADA**

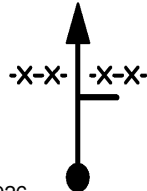
<b>6.69</b>	<b>Neutro</b>
N 1' 8.05.29	
<b>T213</b>	922

<p>6.69</p> <p>V 39 8.06.29</p> <p><b>T214</b></p>	 <p>923</p>
<p>7.06</p>	 <p>924</p>
<p>7.40</p>	 <p>925</p>
<p>7.63</p> <p>V 36 8.07.55</p> <p><b>T215</b></p>	 <p>926</p>
<p>7.76</p>	 <p>927</p>
<p>7.85</p>	 <p>928</p>

7.99	
	929

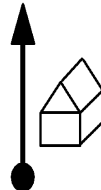
8.16	
	930

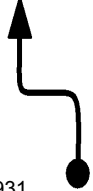
8.33	
	931

8.69	
	932

8.81	
	933

8.87	
	934

8.98	
	935

9.02	
	936

9.33	
<b>0.00</b>	
V 36 8.10.45	
<b>T216</b>	937

0.08	
	938

**COSTEAR A CERCA**

0.18	
	939

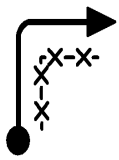
0.49	
	940

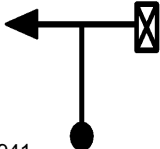
0.52	
	941

1.06	Neutro
N 2' 8.12.31	
<b>T217</b>	942

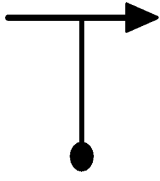
1.06	
<b>0.00</b>	
V 39 8.14.31	
<b>T218</b>	943

0.27	
	944

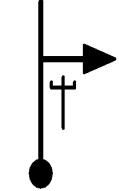

0.70	
	945

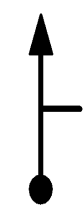
1.08	
	946

NO MATO

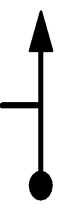
1.26	
V 33 8.16.28	
<b>T219</b>	947

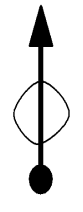
1.41	
	948

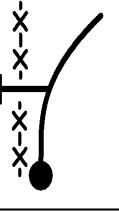
1.63	
	949

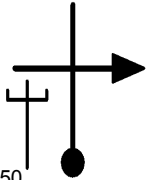
1.67	
V 48 8.17.12	
T220	950

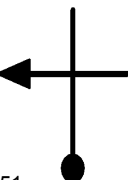
1.73	
	951

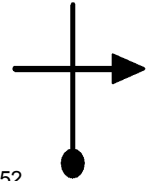
1.91	
	952

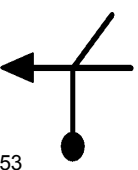
1.97	
	953

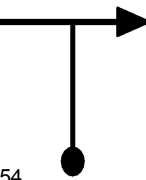
2.19	
	954

2.23	
	955

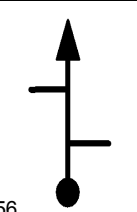
2.66	
	956

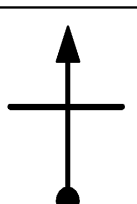
2.80	
	957

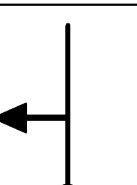
3.03	
	958

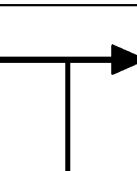
3.15	
	959



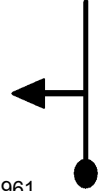

3.27	
	960

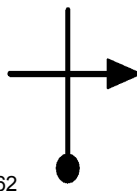
3.30	
	961

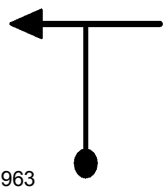
3.52	
	962

3.58	
	963

3.92	
	964

4.15	
	965

<b>CUIDADO ASFALTO</b>	
<b>4.41</b>	<b>Neutro</b>
<b>N3'30s 8.20.38</b>	
<b>T221</b>	966

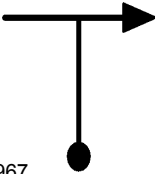
4.41	
V 45 8.24.08	
T222	967

4.72	
	968

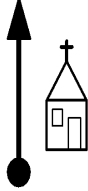
4.94	
	969

5.47	
	970

TRILHO

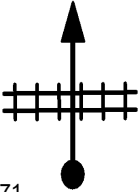
5.98	
	971

6.90	
972	

**CUIDADO AO ATRAVESSAR**

7.40	
973	

**3º APOIO FORQUILHINHA**

7.43	<b>Neutro</b>
N 20' 8.28.09	
<b>T223</b> 974	

7.43	
<b>0.00</b>	
V 42 8.48.09	
<b>T224</b> 975	

0.38	
976	

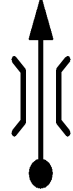
<p>0.63</p>	
	977

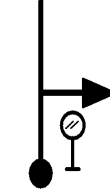

<p>1.29</p>	
	978

<p>1.69</p>	
	979

<p>2.05</p>	
	980

**CUIDADO PARA CRUZAR**

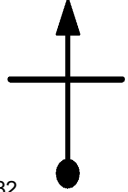
<p>2.86</p>	<p><b>Neutro</b></p>
<p>N 1' 8.52.15</p>	
<p><b>T225</b></p>	981

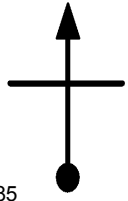
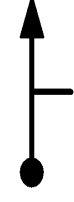
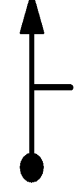
<p>2.86</p> <p>V 39 8.53.15</p> <p>T226</p>	 <p>982</p>
<p>3.69</p>	 <p>983</p>
<p>3.94</p>	 <p>984</p>
<p>4.15</p>	 <p>985</p>
<p>5.00</p>	 <p>986</p>
<p>5.26</p>	 <p>987</p>

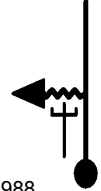

5.36	
V 30 8.57.05	
T227	988

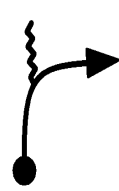
5.49	
	989

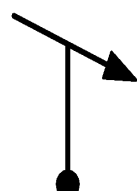
5.72	
	990

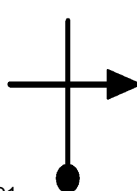
5.82	
	991

5.96	
	992

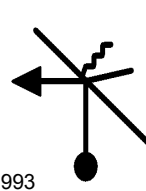
6.06	
	993

6.09	
	994

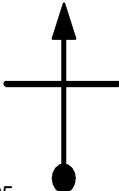
6.19	
	995

6.31	
	996

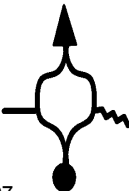
6.42	
	997

ENTRE NO RIO

6.45	
V 12 8.59.17	
<b>T228</b>	998

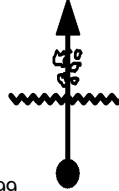
6.47	
	999

**DESÇA DEGRAU**

6.58	
	1000



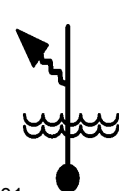

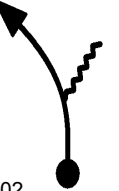
**SAIR DO RIO**

6.64	
	1001

6.66	
	1002

6.70	
V 36 9.00.30	1003

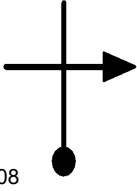
**T229**

6.95	
6.97	
7.24	
7.40	Neutro
N 3' 9.01.41	<b>T230</b> 1007
7.40	
V 36 9.04.41	<b>T231</b> 1008
7.82	
V 30 9.05.23	<b>T232</b> 1009

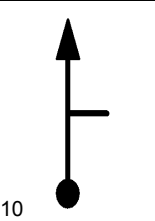
7.93	
	1010

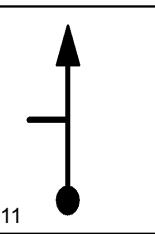
8.16	
	1011

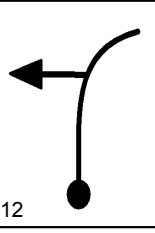
8.18	
	1012

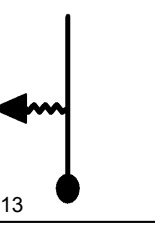
8.39	
	1013

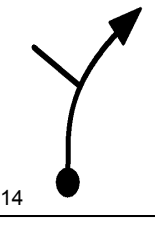
8.48	
	1014

8.67	Neutro
N 2' 9.07.05	
<b>T233</b>	1015

CUIDADO ESTRADA GERAL

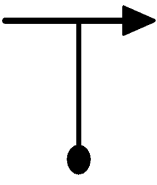
8.67	
0.00	
V 39 9.09.05	
<b>T234</b> 1016	

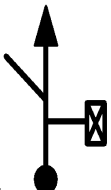
0.06	
1017	

SUBA

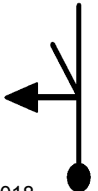
0.26	
V 36 9.09.29	
<b>T235</b> 1018	

0.34	
1019	





0.64	
1020	

0.94	
	1021

**ATENÇÃO!!**

1.06	
V 33 9.10.49	
<b>T236</b>	1022

1.07	
	1023

1.13	
	1024

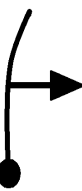
1.22	
	1025

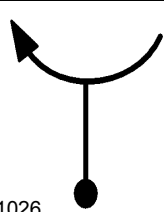
1.37	
	1026

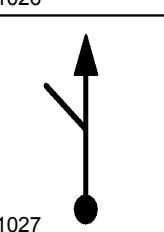
1.39	
	1027

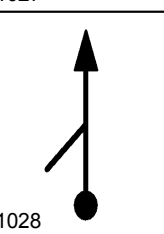
1.46	
	1028

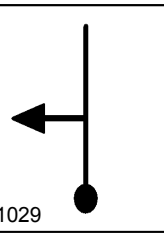
1.53	
	1029

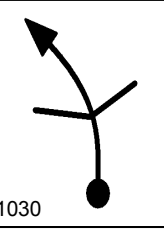
1.55	
	1030

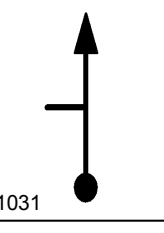
1.64	
	1031



1.67	
	1032

1.91	
V 30 9.12.22	
<b>T237</b>	1033

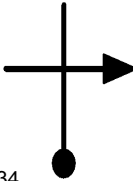
1.94	
	1034

1.96	
	1035

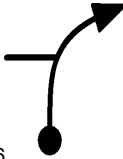
2.02	
	1036

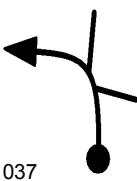
2.06	
	1037

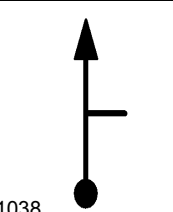
2.09	
	1038

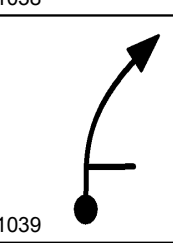
2.13	
	1039

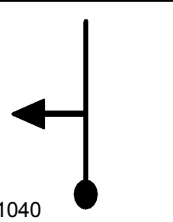
2.19	
	1040

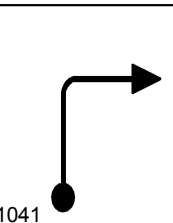
2.21	
	1041

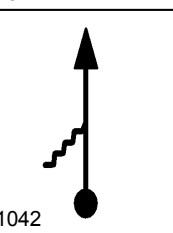
2.24	
	1042

2.44	Neutro
N 2' 9.13.26	
<b>T238</b>	1043

2.44	
V 33 9.15.26	1044

**T239**

2.66	
	1045

**PELO MEIO LAJE**

3.02	
	1046

3.25	
	1047

3.28	
	1048

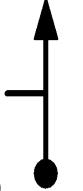
3.37	
	1049

3.41	
	1050

RAIZ

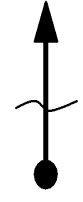
3.46	
	1051

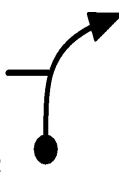
3.55	
	1052

3.56	
	1053

3.58	
	1054

3.65	
	1055

3.68	
	1056

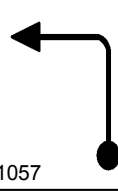
3.71	
	1057

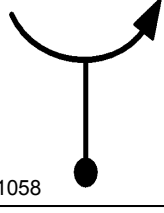
3.73	
	1058

3.79	
	1059

3.83	
	1060

3.86	
	1061

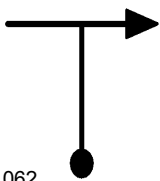
3.87	
	1062

3.95	
	1063

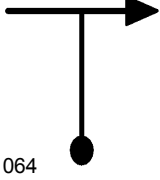
3.99	
	1064

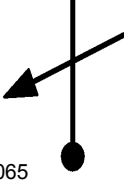
4.03	
	1065

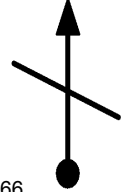
4.05	
	1066

4.08	
	1067

4.10	Neutro
N 3' 9.18.27	
<b>T240</b>	1068

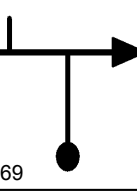
4.10	
V 42 9.21.27	
<b>T241</b>	1069

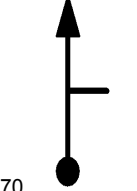
4.33	
	1070

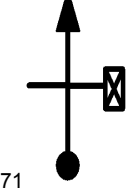
4.59	
	1071

PARE RUA MOVIMENTADA

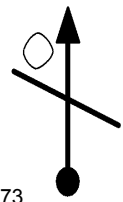
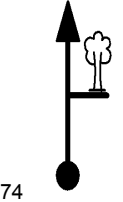
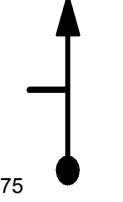
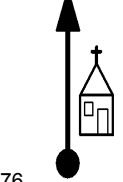
<p>5.04</p> <p>N 30s 9.22.47</p> <p><b>T242</b></p>	<p>Neutro</p> <p>1072</p>
<p>5.04</p> <p>V 42 9.23.17</p> <p><b>T243</b></p>	 <p>1073</p>
<p>5.49</p>	 <p>1074</p>
<p>5.83</p>	 <p>1075</p>
<p>6.50</p>	 <p>1076</p>

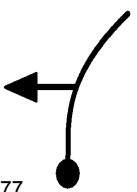

6.77	
	1077

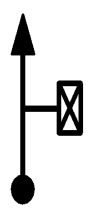
7.10	
	1078

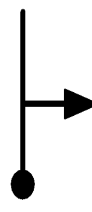
7.25	
V 33 9.26.27	
<b>T244</b>	1079

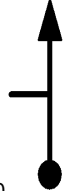

7.30	
	1080

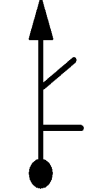
7.37	
	1081

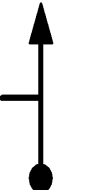
7.50	
	1082

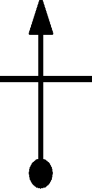
7.67	
	1083

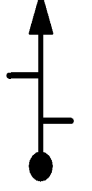
7.80	
	1084

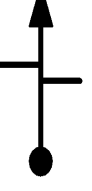
7.89	
	1085

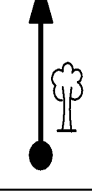
8.00	
	1086

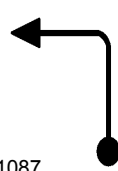
8.05	
	1087

8.11	
	1088

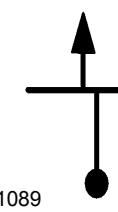
8.18	
	1089

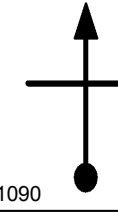
8.44	
	1090

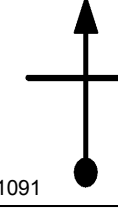
8.47	
	1091

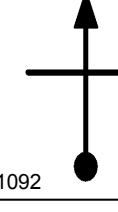
8.50	
	1092

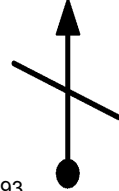
8.55	
	1093

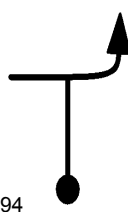
8.61	
	1094

8.66	
	1095

8.77	
	1096

**BARRANCO**

8.90	
	1097

8.99	
	1098

9.07	
	1099

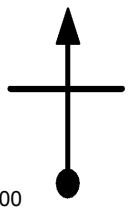
9.10	
	1100

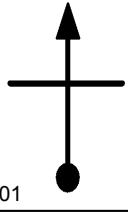
9.13	
	1101

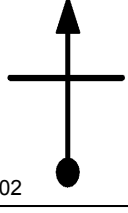
9.20	
	1102

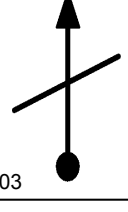
9.35	
	1103

DESCE

9.38

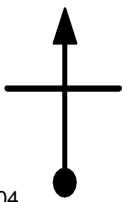

1104

9.43

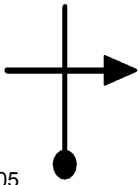

1105

9.53



1106

9.60

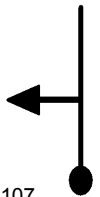





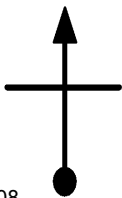

1107

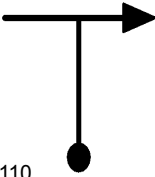
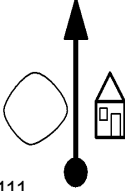
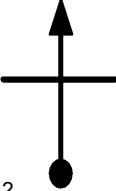
9.62

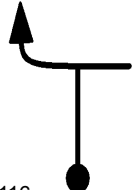

1108

9.80	Neutro
N 3' 9.31.05	
	T245 <sup>1109</sup>
9.80	
V 30 9.34.05	
	T246 <sup>1110</sup>
10.08	
	1111
10.16	
V 33 9.34.48	
	T247 <sup>1112</sup>
10.38	
	1113
10.41	
	1114

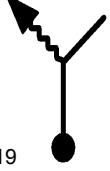
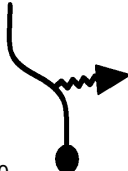
10.46	
10.61	
10.66	
10.75	
10.82	
V 27 9.36.00 <b>T248</b>	

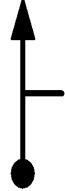

11.06	
	1121

11.14	Neutro
N2'30s 9.36.43	
<b>T249</b>	1122

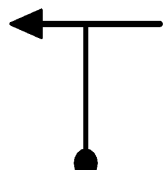
11.14	
V 39 9.39.13	
<b>T250</b>	1123

11.35	
	1124

11.98	
<b>0.00</b>	
V 39 9.40.30	
<b>T251</b>	1125

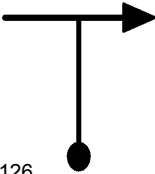
0.05	
	1126

MUITO CUIDADO!!

0.25	Neutro
N 30s 9.40.54	
<b>T252</b>	1127

0.25	
V 36 9.41.24	
<b>T253</b>	1128

ATRAVessar VIADUTO

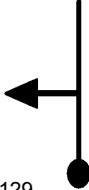
0.35	
	1129

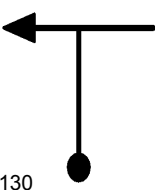
0.41	
	1130

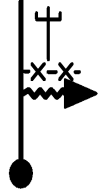
0.52	
V 33 9.41.51	
	T254 1131

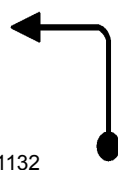
0.68	
	1132

0.70	Neutro
N 30s 9.42.10	
	T255 1133

**CUIDADO ESTRADA GERAL**

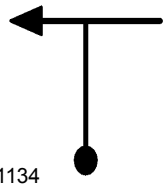
0.70	
V 33 9.42.40	
	T256 1134

0.72	
	1135

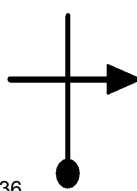
0.82	
	1136

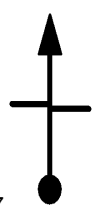
0.92	
	1137

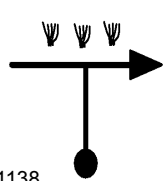
0.98	
	1138

**CUIDADO ESTRADA GERAL**

1.13	Neutro
N 30s 9.43.27	
<b>T257</b>	1139

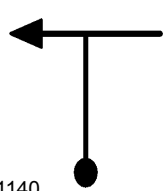

1.13	
V 42 9.43.57	
<b>T258</b>	1140

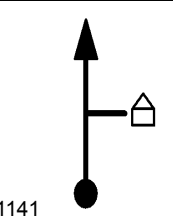
1.72	
	1141

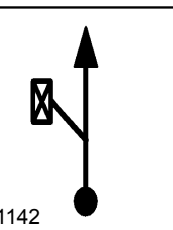
1.99	
	1142

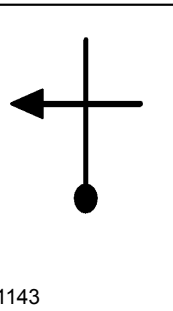
2.31	
<b>0.00</b>	
<b>V 33 9.45.38</b>	
<b>T259</b>	1143

<b>RESPEITE A ROÇA</b>	
0.40	
	1144

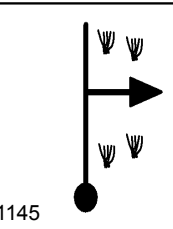
0.42	
	1145

COSTEAR VALO

0.46	
	1146

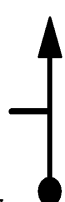
1.06	
	1147

1.44	Neutro
N 1' 9.48.16	
<b>T260</b>	1148

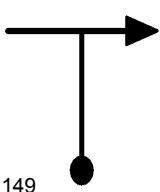
1.44	
V 33 9.49.16	
<b>T261</b>	1149

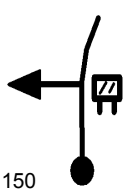
2.16	
	1150

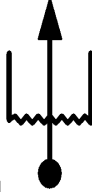
3.09	
	1151

TRILHA ESCONDIDA

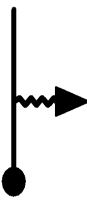
3.35	
V 18 9.52.44	
<b>T262</b>	1152

3.56	
	1153

3.73	
	1154

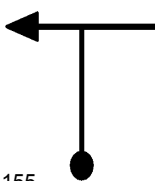
3.95	
	1155

4.07	
	1156

**CUIDADO ROÇA RESPEITE**

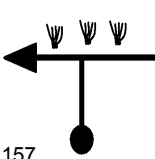
4.19	
V 33 9.55.32	
<b>T263</b>	1157

**RESPEITE A ROÇA**

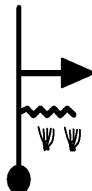
4.29	
	1158

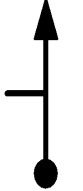
4.68	
	1159

4.87	
	1160



CUIDADO ESTRADA GERAL

4.92	Neutro
N2'30s 9.56.51	
<b>T264</b>	1161

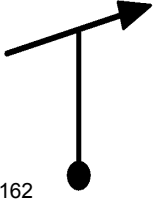
4.92	
V 42 9.59.21	
<b>T265</b>	1162

5.11	
	1163

PENITENCIARIA

5.22	
	1164

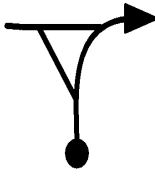
5.76	
<b>0.00</b>	
V 39 10.00.33	
<b>T266</b>	1165

0.70	
	1166

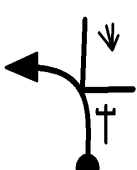
1.10	
	1167

1.52	
V 30 10.02.54	
<b>T267</b>	1168

**COSTEAR O MATO**

1.62	
	1169

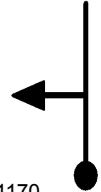
1.84	
	1170

COSTEAR O VALO

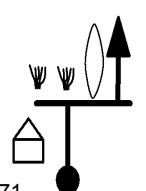
1.89	
	1171

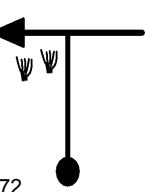
2.00	
	1172

NO MATO

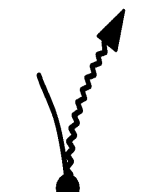
2.03	
V 27 10.03.55	
<b>T268</b>	1173

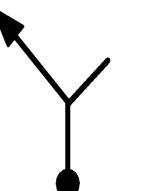
2.57	
	1174

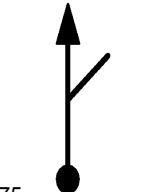
2.61	
	1175

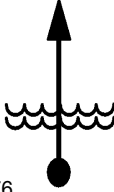
2.65	
	1176

**COSTEAR A ROÇA E MATO**

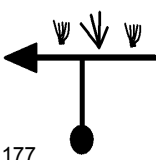
2.73	
V 30 10.05.28	
<b>T269</b>	1177

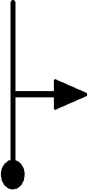
2.97	
	1178

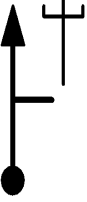
3.06	
	1179

3.18	
	1180

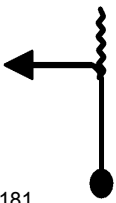
3.22	
	1181

**ATENÇÃO**

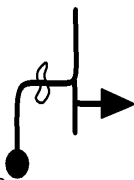
3.30	
	1182

3.55	
	1183

3.60	
	1184

3.74	<b>Neutro</b>
N 3' 10.07.29	
<b>T270</b>	1185

3.74	
V 27 10.10.29	
<b>T271</b>	1186



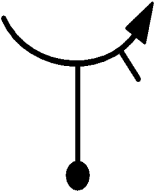

**CUIDE DA GRAMA**

3.78	
	1187

3.83	
<b>0.00</b>	
V 42 10.10.42	
<b>T272</b>	1188

0.27	
	1189

0.91	
	1190

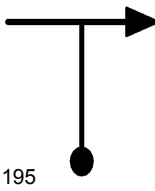
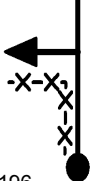
<p>1.45</p> <hr/> <hr/>	 <p>1191</p>
<p>1.88</p> <hr/> <hr/>	 <p>1192</p>
<p>2.16</p> <hr/> <hr/>	 <p>1193</p>
<p>2.85</p> <hr/> <hr/>	 <p>1194</p>
<p>3.36</p> <hr/> <hr/>	 <p>1195</p>
<p>3.49</p> <hr/> <p>V 30 10.15.41</p> <p><b>T273</b></p>	 <p>1196</p>

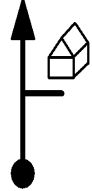
3.88	
V 39 10.16.28	
<b>T274</b>	1197

4.37	
	1198

HORA DE LIMPAR A VELA

4.75	Neutro
N 30s 10.17.48	
<b>T275</b>	1199

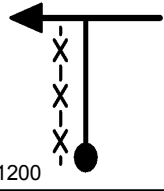

4.75	
V 49 10.18.18	
<b>T276</b>	1200



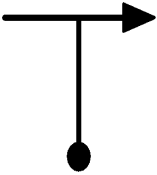

4.85	
0.00	
V 49 10.18.25	
T277	1201

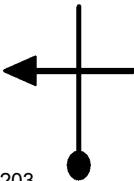
0.13	
	1202

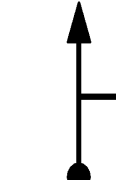
0.48	
	1203

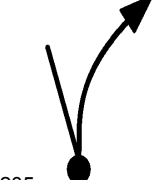
0.60	
	1204

0.73	
	1205

0.77	
	1206

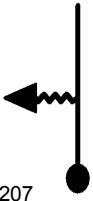
0.87	
	1207

1.28	
	1208

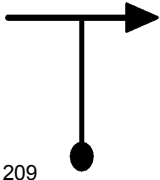
1.69	
	1209

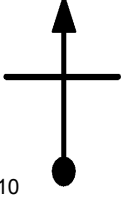
2.40	
	1210

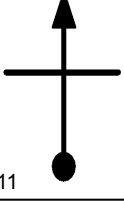
2.57	
	1211

2.82

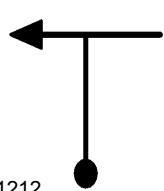

1212

2.92

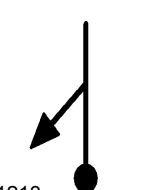

1213

3.34

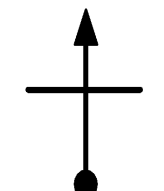

1214

3.75

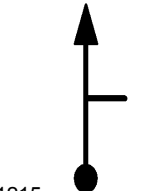

1215

3.93

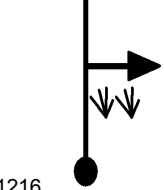





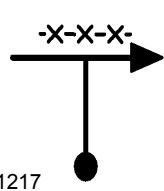

1216

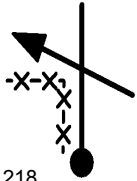
4.01

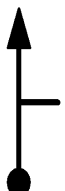

1217

<p>4.21</p>	 <p>1218</p>
<p>4.34</p>	 <p>1219</p>
<p>4.67</p> <p><b>0.00</b></p> <p>V 54 10.24.09</p> <p><b>T278</b></p>	 <p>1220</p>
<p>0.16</p>	 <p>1221</p>
<p>0.33</p>	 <p>1222</p>

0.47	
	1223

**CUIDADO GERAL**

0.50	Neutro
N 4' 10.24.42	
	<b>T279</b> 1224

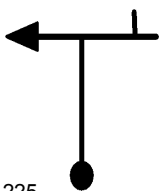
0.50	
V 42 10.28.42	
	<b>T280</b> 1225

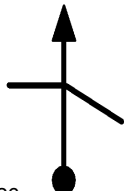
0.98	
	1226

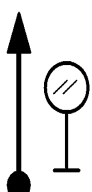
1.80	
	1227

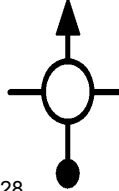
1.95	
	1228

3.18	
	1229

3.67	
V 42 10.33.14	
<b>T281</b>	1230

3.69	
	1231

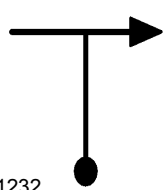
3.95	
	1232

3.98	
	1233

4.30	
V 27 10.34.08	
	<b>T282</b> 1234

4.37	
V 42 10.34.18	
	<b>T283</b> 1235

4.65	
V 27 10.34.42	
	<b>T284</b> 1236

4.73	
	1237

4.77	
V 21 10.34.57	
	<b>T285</b> 1238

4.80	
	1239

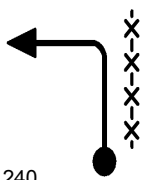
4.84	
	1240

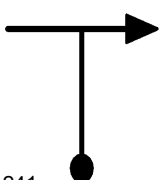
4.87	
V 42 10.35.15	1241
	T286

5.18	
	1242

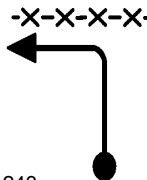
5.58	
V 30 10.36.16	1243
	T287

**CUIDADO CERCA**

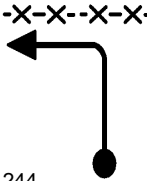
5.65	
	1244

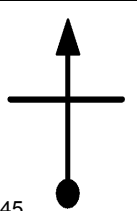

6.05 

V 42 10.37.12  
T288 1245

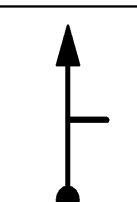
6.30 

1246

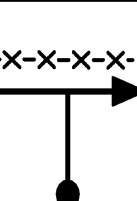
6.43 

1247

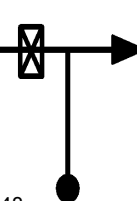
6.50 

V 49 10.37.51  
T289 1248

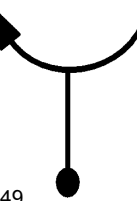
6.90 

1249

7.96 **Neutro**

N3'30s 10.39.38  
T290 1250

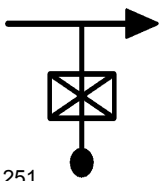
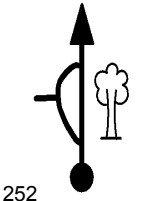
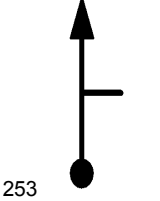
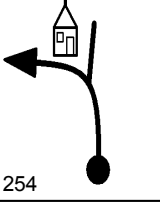
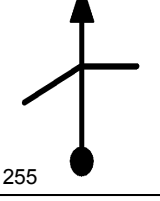
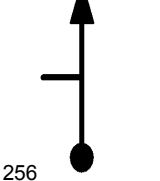
<p>7.96</p> <p>V 42 10.43.08</p> <p><b>T291</b></p>	 <p>1251</p>
<p>8.30</p>	 <p>1252</p>
<p>9.27</p>	 <p>1253</p>
<p>9.32</p>	 <p>1254</p>
<p>10.15</p>	 <p>1255</p>
<p>10.96</p>	 <p>1256</p>

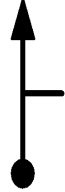
11.73	
	1257

**ACELERAA**

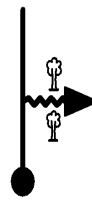
11.79	
V 49 10.48.36	
<b>T292</b>	1258

12.38	
	1259

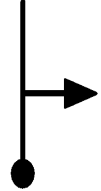

13.11	
<b>0.00</b>	
V 49 10.50.13	
<b>T293</b>	1260

0.37	
	1261

0.94	
	1262

**CUIDADO ESTRADA GERAL**

2.04	Neutro
N 3' 10.52.44	
<b>T294</b>	1263

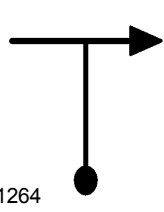
2.04	
V 42 10.55.44	
<b>T295</b>	1264

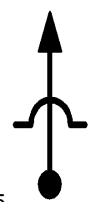
2.15	
	1265

2.92	
	1266

TREVO



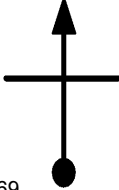

3.00	
	1267

CUIDADO!!

3.05	Neutro
N 1' 10.57.11	
	<b>T296</b> 1268

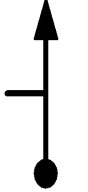
3.05	
V 42 10.58.11	
	<b>T297</b> 1269

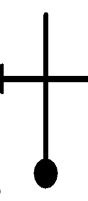
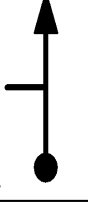
4.19	
	1270

<p>4.50</p>	 <p>1271</p>
<p>4.99</p>	 <p>1272</p>
<p>5.26</p> <p>V 39 11.01.20</p> <p><b>T298</b></p>	 <p>1273</p>
<p>5.59</p>	 <p>1274</p>
<p>5.99</p>	 <p>1275</p>
<p>6.47</p>	 <p>1276</p>

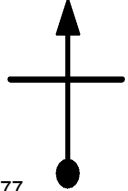
<p>7.02</p>	
	1277

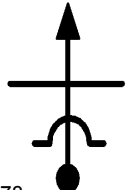
<p>7.33</p>	
	1278

**CUIDADO AO ATRAVESSAR**

<p>7.65</p>	<p>Neutro</p>
<p>N 1' 11.05.00</p>	
<p><b>T299</b></p>	1279

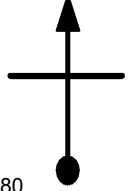
<p>7.65</p>	
<p>V 39 11.06.00</p>	
<p><b>T300</b></p>	1280

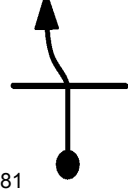
<p>8.29</p>	
	1281

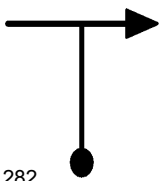
8.78	
	1282

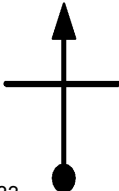
8.90	
	1283

**PARE!!**

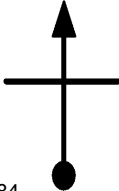
9.08	
	1284

**PARE!!**

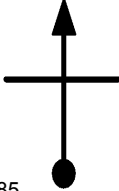
9.27	
	1285

**PARE!!**

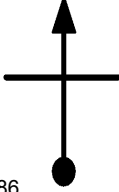
9.46	
	1286

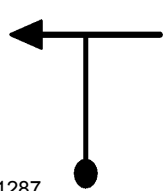

9.65	
	1287

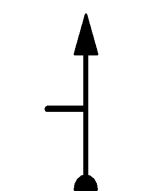
9.72	
	1288

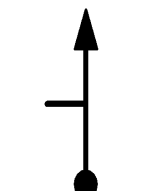
9.94	
	1289

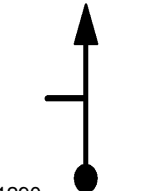
10.09	
	1290

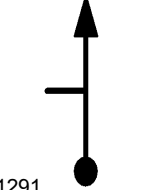
10.24	
	1291

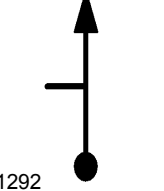
10.32	
	1292

10.76	
	1293

11.06	
	1294

**FIM DE PROVA! ENTREGUE GPS**

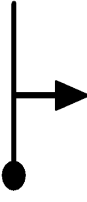
11.20	
N 0h 11.11.27	
<b>T301</b>	1295

**FIM DE PROVA !!**



[www.t15.com.br](http://www.t15.com.br)

**Tempo de Prova**

**Estreantes 11:11:27**

