

INICIO

Junior

ENDURO LUA CHEIA
LUA CHEIA

IMPORTANTE

 CUIDADO

 ATENÇÃO

 MUITA ATENÇÃO

Tempo de Prova

Junior 11:11:02



AFERIÇÃO

INICIO AFERIÇÃO

0.00

0.00

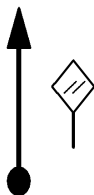

AFER

1

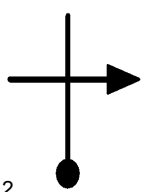
0.05	

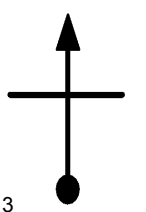
0.12	

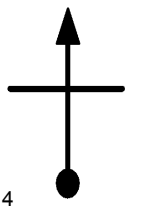
0.17	

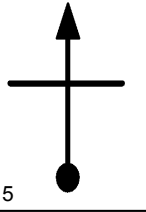
0.37	

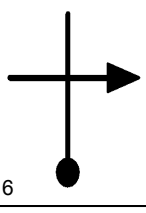
0.57	

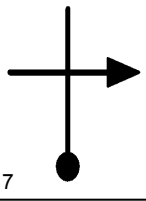
0.64	

0.76	
	8

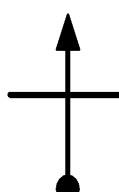
0.83	
	9

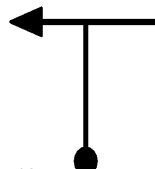
1.03	
	10

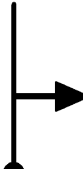
1.07	
	11

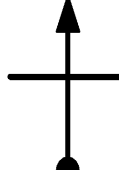
1.14	
	12

FIM AFERIÇÃO

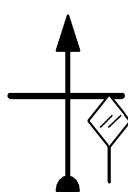
1.21	
	13



INICIO DE PROVA

INICIO DE PROVA

0.00

0.00

V 21 0.00.00

T1

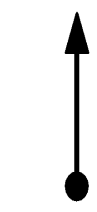

14

0.05

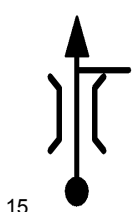

15

0.13

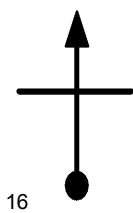

16

0.21

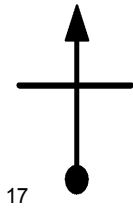

17

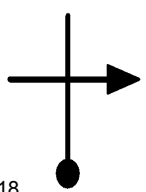
0.29	
	18

ATENÇÃO AO CRUZAR

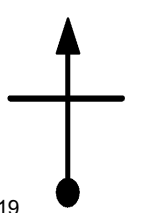
0.45	
	19

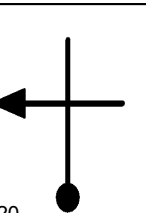
0.59	
	20

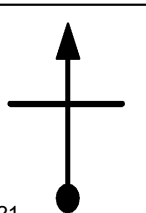
0.66	
	21

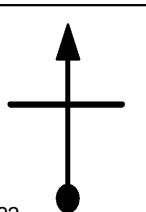
0.74	
	22

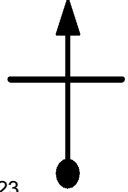
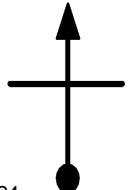
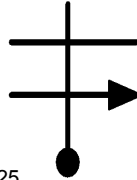
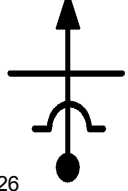
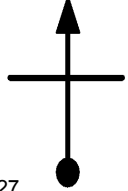
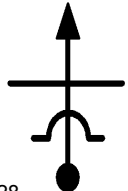
<p>0.81</p> <hr/> <hr/>	 <p>23</p>
<p>0.89</p> <hr/> <hr/>	 <p>24</p>
<p>0.96</p> <p>V 33 0.02.45</p> <p>T2</p>	 <p>25</p>
<p>1.14</p> <hr/> <hr/>	 <p>26</p>
<p>1.44</p> <hr/> <hr/>	 <p>27</p>
<p>1.50</p> <hr/> <hr/>	 <p>28</p>

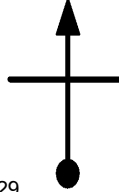
1.68	
	29

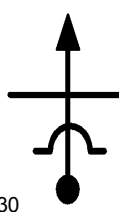
1.85	
	30

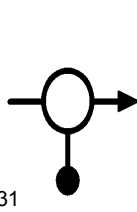
2.05	
	31

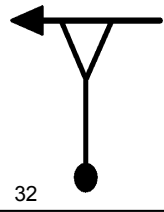
2.53	
	32

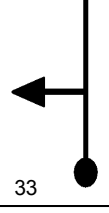
2.74	
	33

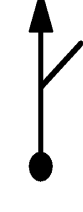
2.82	
0.00	
V 33 0.06.08	
T3	34

0.05	
	35

0.12	
	36

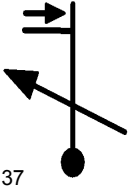
0.24	
	37

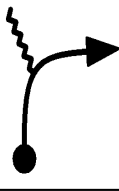
0.41	
	38

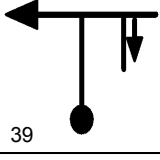
0.60	
	39

0.62	
	40

0.77	
	41

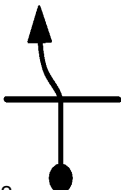
0.81	
	42

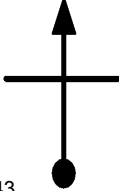
0.90	
	43

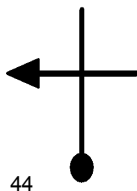
1.00	
	44

1.11	
	45

1.24	
	46

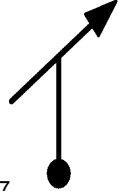
1.34	
	47

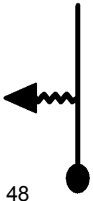
1.37	
	48

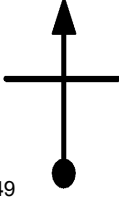
1.46	
	49

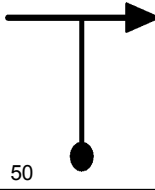
1.65	
	50

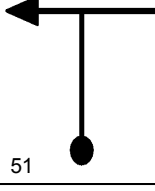
1.81	
	51

1.88	
	52

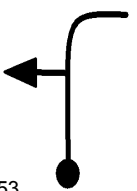
1.94	
	53

CUIDADO GERAL

2.22	Neutro
N 2' 0.10.11	
T4	54

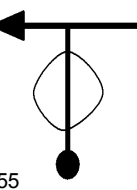
2.22	
V 45 0.12.11	
T5	55

2.87	
V 42 0.13.03	
T6	56

2.94	
	57

3.37	
	58

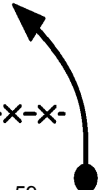
3.54	
V 39 0.14.00	59
T7	



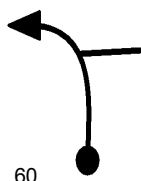

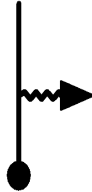
3.73	
	60

3.87	
	61

<p>4.15</p>	 <p>62</p>
-------------	--------------------------------------------------------------------------------------------

<p>4.20</p>	<p>Neutro</p>
<p>N 2' 0.15.01</p>	<p>63</p>
<p>T8</p>	

<p>4.20</p>	 <p>64</p>
<p>V 42 0.17.01</p>	
<p>T9</p>	

<p>4.37</p>	 <p>65</p>
-------------	----------------------------------------------------------------------------------------------

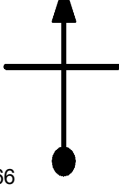
<p>4.52</p>	 <p>66</p>
-------------	-----------------------------------------------------------------------------------------------

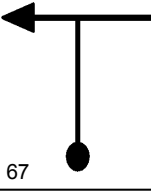
<p>4.64</p>	 <p>67</p>
-------------	-----------------------------------------------------------------------------------------------

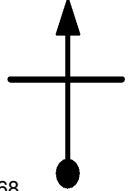
4.77	
	68

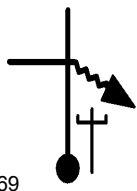
4.91	
V 42 0.18.02	69
	T10

5.09	
	70

CUIDADO GERAL

5.69	Neutro
NI'30s 0.19.09	71
	T11

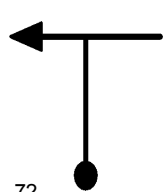
5.69	
V 39 0.20.39	72
	T12

6.07	
	73

6.54	
	74

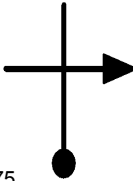
6.65	
	75

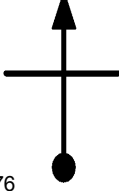
6.73	
	76

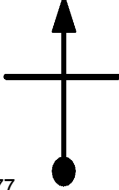
6.80	
	77

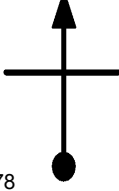
6.87	
	78

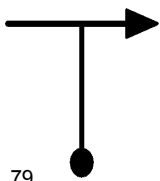
7.01	
	79

SUBA ACELERE!!

7.57	
V 36 0.23.32	80
T13	

7.70	
	81

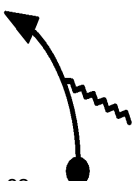
8.04	
	82

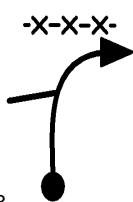
8.08	
	83

<p>8.25</p>	 <p>84</p>
-------------	--------------------------------------------------------------------------------------------

<p>8.28</p>	 <p>85</p>
-------------	---------------------------------------------------------------------------------------------

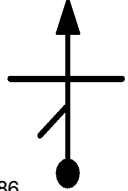
<p>8.64</p>	 <p>86</p>
-------------	---------------------------------------------------------------------------------------------

CUIDADO VALO

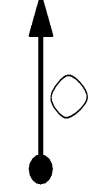
<p>9.03</p>	 <p>87</p>
-------------	----------------------------------------------------------------------------------------------

<p>9.23</p>	<p>Neutro</p>
<p>N 3' 0.26.18</p>	<p>88</p>
<p>T14</p>	

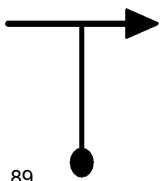
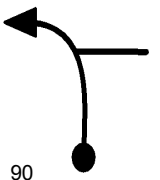
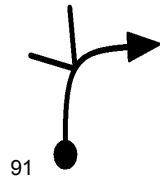
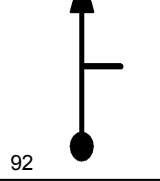
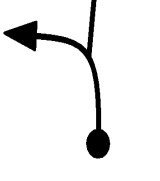
<p>9.23</p>	
<p>V 42 0.29.18</p>	<p>89</p>
<p>T15</p>	
<p>9.51</p>	
	<p>90</p>
<p>9.72</p>	
	<p>91</p>
<p>9.97</p>	
	<p>92</p>
<p>10.42</p>	
<p>0.00</p>	
<p>V 42 0.31.01</p>	<p>93</p>
<p>T16</p>	

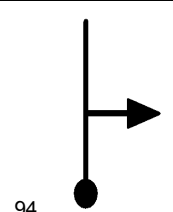
0.78	
	94

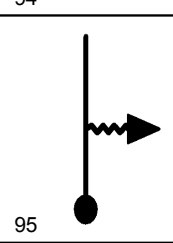
1.17	
V 42 0.32.41 T17	95

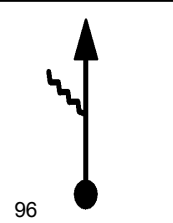
1.25	
	96

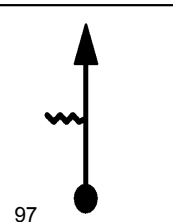
1.72	
	97

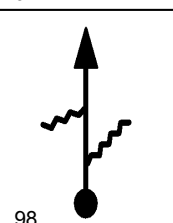
1.97	
	98

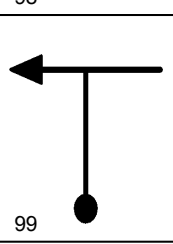
2.10	
	99

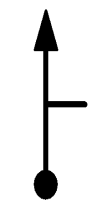
2.19	
	100

EROSOES

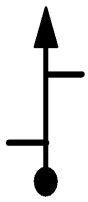
2.26	
V 27 0.34.15	101
T18	

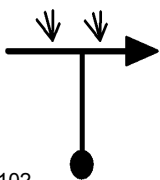
2.35	
	102

2.45	
	103

NO MATO DESÇA

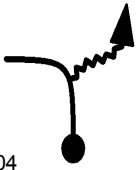
2.50	
	104

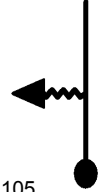
2.77	
	105

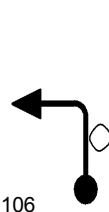
2.83	
	106

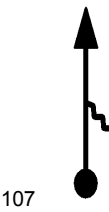
2.92	
	107

3.02	
	108

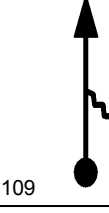
3.11	
	109

3.15	
	110

3.18	
V 33 0.36.17	111

COSTEAR ROÇA

3.35	
	112

ATENÇÃO

3.48	
	113

3.51	
	114

ATENÇÃO

3.80	
	115

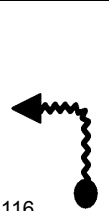
3.88	
	116

NA CANA

3.96	
	117

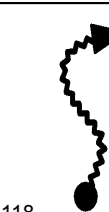
3.98	
	118

4.00	
	119

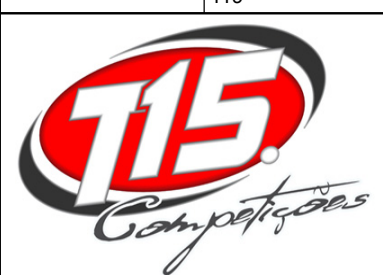

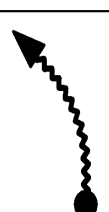
4.03	
	120

4.07	
	121

4.16	
	122

4.22	
	123

CUIDADO GERAL

4.27	Neutro
N2'30s 0.38.16	
T20	124

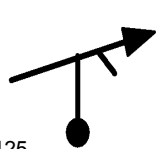
4.27	
V 42 0.40.46	
T21	125

4.77

126

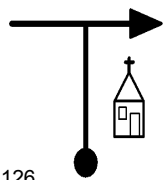

5.28

127

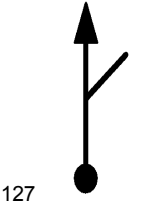

5.85

128

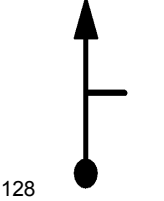

6.22

129

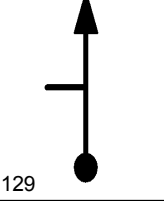

6.54

130

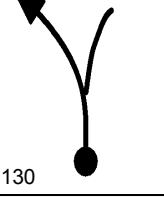

6.82

131

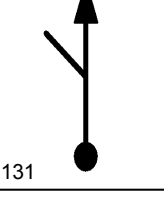

7.99

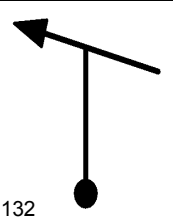

132

8.27

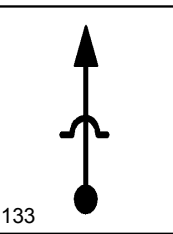

133

8.72

V 39 0.47.07

T22

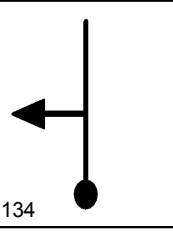

134

8.80

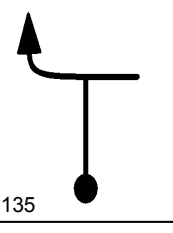

135

8.91

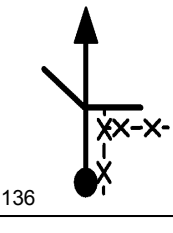

136

9.04

-x-x-x-x-

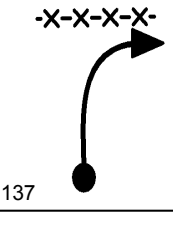

137

9.07

138

9.14

139

9.24

140

9.41

Neutro

N 2' 0.48.11

T23

141

9.41



V 42 0.50.11

T24

142

9.51

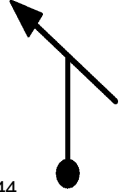
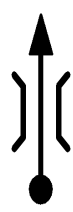
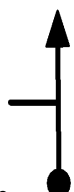
143

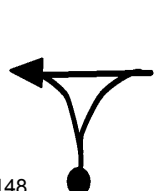
<p>9.54</p> <hr/> <hr/>	 <p>144</p>
<p>9.93</p> <p>0.00</p> <p>V 42 0.50.56</p> <p>T25</p>	 <p>145</p>
<p>0.12</p> <hr/> <hr/>	 <p>146</p>
<p>1.24</p> <hr/> <hr/>	 <p>147</p>
<p>1.83</p> <hr/> <hr/>	 <p>148</p>

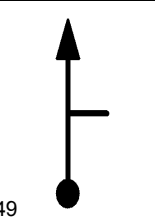
2.66	
	149

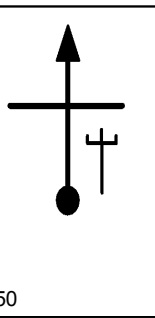
3.65	
0.00	
V 42 0.56.09	
T26	150

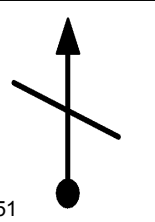
0.71	
	151

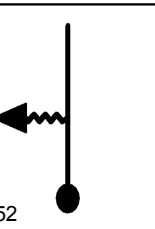
0.89	
V 45 0.57.25	
T27	152

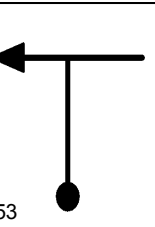
1.26	
	153

1.32	
	154

NO MATO

1.41	
V 42 0.58.07	
T28	155

1.59	
	156

1.71	
	157

2.25	
	158

2.29	
	159

2.41	
	160

2.45	
	161

2.48	
	162

TOCO ESCONDIDO

2.55	
	163

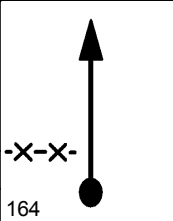
2.59	
	164

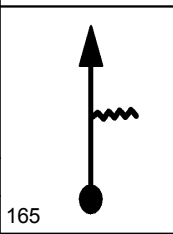
2.62	
	165

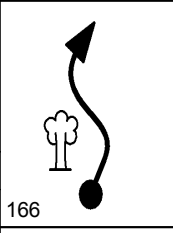
2.63	
	166

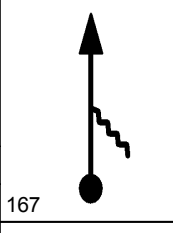
2.77	
	167

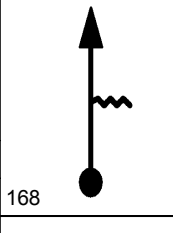
2.82	
	168

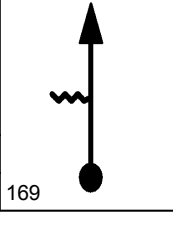
2.83	
	169

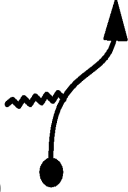
2.91	
	170

3.29	
	171

GERAL CUIDADO

3.43	Neutro
N2'30s 1.01.00	
T29	172

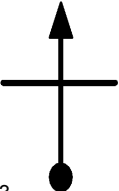
3.43	
V 45 1.03.30	
T30	173

3.56	
	174

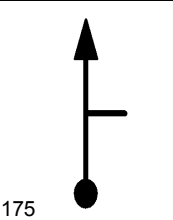
3.68	
	175

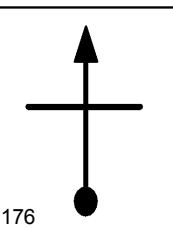
3.72	
	176

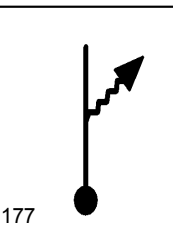
3.76	
V 42 1.03.56 T31	177

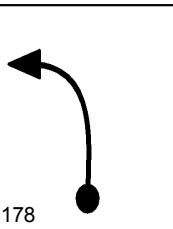
3.80	
	178

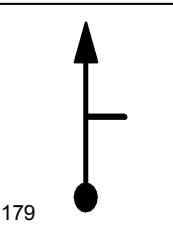
3.84	
	179

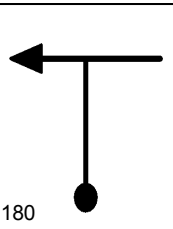

3.96	
	180

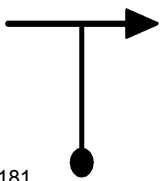
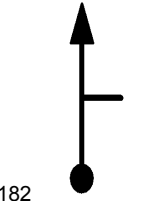
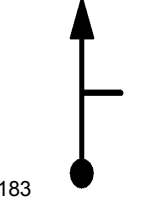
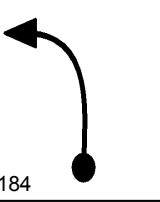
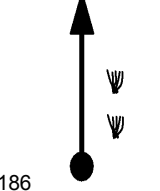
<p>4.01</p> <p>V 45 1.04.18</p> <p>T32</p>	 <p>181</p>
<p>4.10</p>	 <p>182</p>
<p>4.16</p>	 <p>183</p>
<p>4.27</p>	 <p>184</p>
<p>4.86</p> <p>N 2' 1.05.26</p> <p>T33</p>	<p>Neutro</p> <p>185</p>
<p>4.86</p> <p>V 27 1.07.26</p> <p>T34</p>	 <p>186</p>

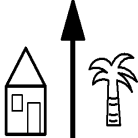
4.98	
	187

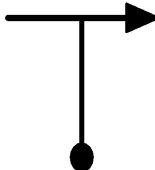
5.09	
0.00	
V 42 1.07.56	
T35	188

0.60	
	189

CUIDADO AO ATRAVESSAR!!!

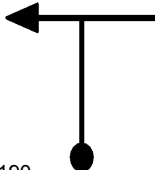
1.39	
	190

1.41	
	191

1.75	
	192

1.98	
	193

2.22	
	194

2.54	
	195

2.99	
	196

3.38	
V 48 1.12.46	
T36	197

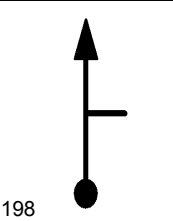
4.74	
	198

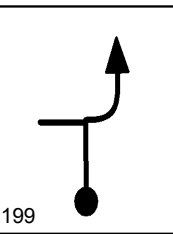
4.90	
	199

CUIDADO MOTOS

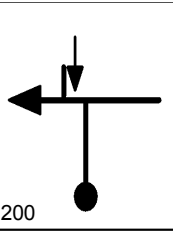
5.21	
V 42 1.15.04	
T37	200

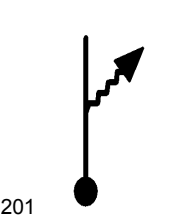
5.39	
	201

5.43	
	202

5.71	
	203

NO MATO

5.78	
	204

5.84	
	205

6.15	
	206

6.18	
	207

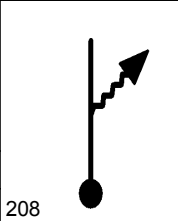
6.36	
	208

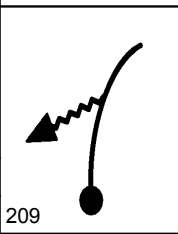
6.40	
	209

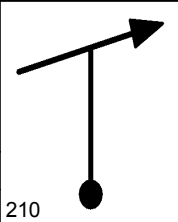
6.44	
	210

CUIDADO MOTOS

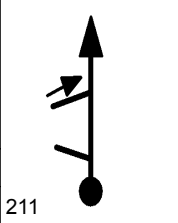
6.46	
	211

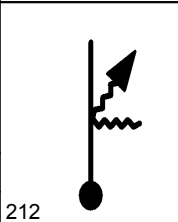
6.50	
	212

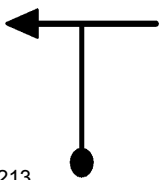
6.66	
	213

CUIDADO MOTOS

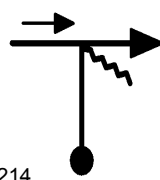
6.70	
	214

CUIDADO MOTOS

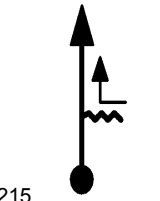
6.80	
	215

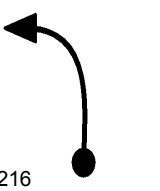
7.21	
	216

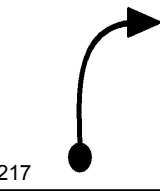
7.23	
	217

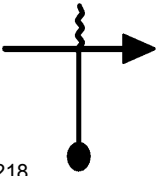
7.47	
	218

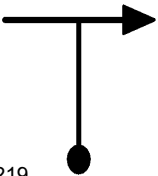
7.56	
	219

8.08	
	220

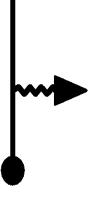
8.20	
	221

CUIDADO MOTOS

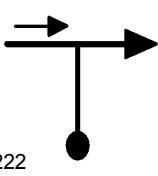
8.27	
	222

8.68	
	223

8.70	
	224

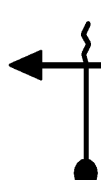
8.93	
	225

9.04	
	226

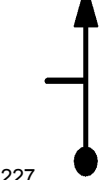
9.08	
	227

9.30	
	228

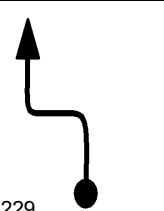
9.40	
	229

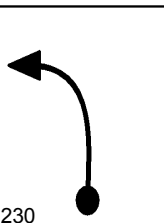
9.44	
V 48 1.21.06	
T38	230

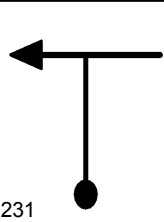
9.50	
V 42 1.21.11	
T39	231

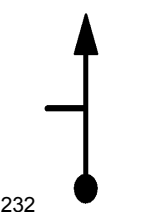
9.85	
	232

CUIDADO MOTOS

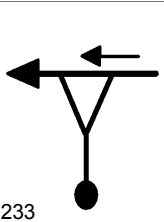
10.58	
V 39 1.22.43	
T40	233

10.61	
	234

CUIDADO MOTOS	
10.75	
	235

CUIDADO MOTOS	
10.85	
	236

11.27	
	237

11.29	
	238





11.52	
	239



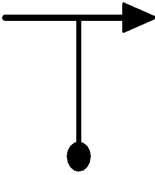

11.61	
	240

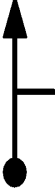
12.40	
N3'30s 1.25.31	
T41	241

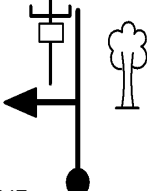
12.40	Neutro
V 27 1.29.01	
T42	242

12.62	
0.00	
V 42 1.29.30	
T43	243
0.60	
	244
0.88	
	245
1.58	
	246
2.34	
V 36 1.32.51	
T44	247

2.42		
	248	

2.82		
	249	

3.17		
V 30 1.34.14		
T45	250	

CUIDADO PONTE

3.30		
	251	

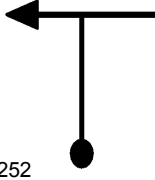
3.32		
	252	

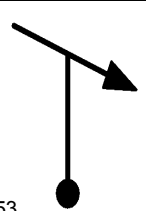
3.50	
	253

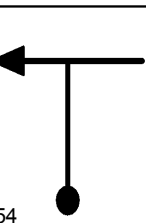
3.56	
	254

3.90	Neutro
NI'30s 1.35.41	
T46	255

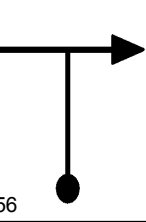
3.90	
V 36 1.37.11	
T47	256

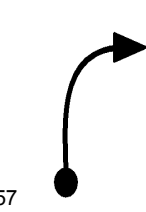
4.14	
	257

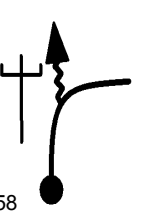
4.44	
	258

CUIDADO VALOS

4.55

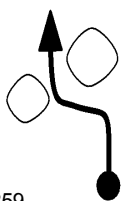

259

4.69

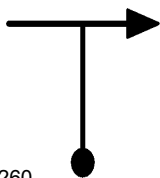

260

4.96



261

5.03



262

5.68

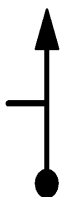

263

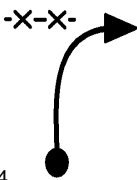
5.79	-x-x- 
	264

6.46	Neutro
N 2' 1.41.28	
T48	265

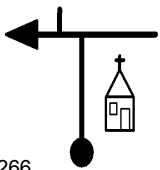
6.46	
V 42 1.43.28	
T49	266

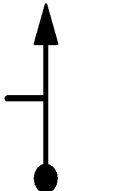
7.09	
	267

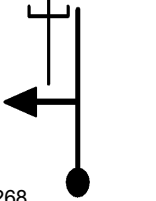
8.58	
V 36 1.46.30	
T50	268

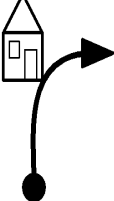
9.20	
	269

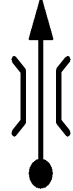
9.25	
	270

9.35	
V 42 1.47.46	
T51	271

9.63	
	272

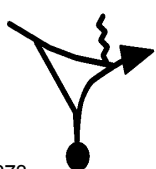
10.71	
	273

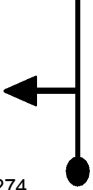
10.87	
	274

11.31	
V 33 1.50.34	
T52	275

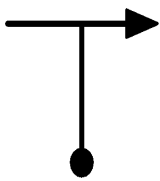
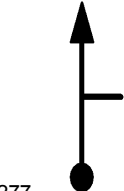
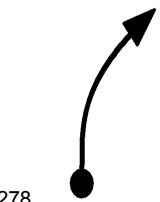
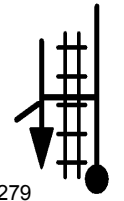
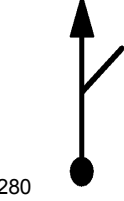
11.96	
0.00	
V 42 1.51.46	
T53	276
0.29	
	277
0.67	
	278
0.79	
	279
0.87	
	280

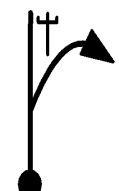

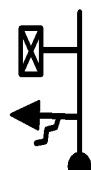

1.04	
	281

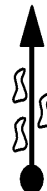
1.65	
V 27 1.54.07	
T54	282

1.81	
	283

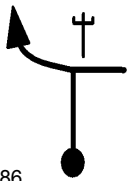
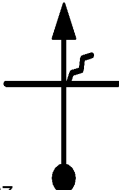
SUBIDA COM EROSIÃO	
1.91	
V 33 1.54.43	
T55	284

DESCIDA COM EROSIÃO	
2.12	
	285

2.50	
V 39 1.55.46	
T56	286
3.15	
	287
3.30	
V 39 1.57.01	
T57	288
3.37	
	289
3.58	
	290
3.79	
	291

3.93	
V 21 1.57.59	
T58	292

ATENÇÃO

4.00	
	293

4.12	
	294

4.16	
	295

4.24	
	296

SUBIDA COM EROÇÃO

4.34



297

4.67

Neutro

Nº 30s 2.00.05

T59

298

4.67

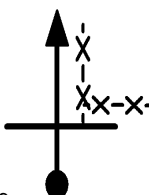

V 36 2.04.35

T60

299



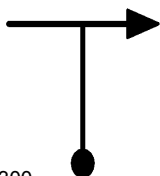

4.96

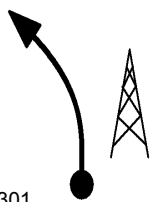

300

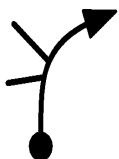
5.81	
	301

6.44	
	302

6.58	
	303

CUIDADO GERAL

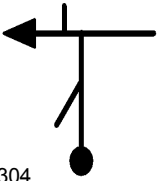
7.10	
	304

7.21	
	305

1º APOIO SANGÃO

7.30 Neutro

N 20' 2.08.58

T61 306

7.30

0.00

V 42 2.28.58

T62 307

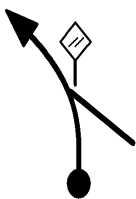

0.80

308

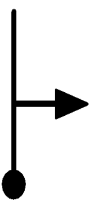

1.03

309





1.13

V 36 2.30.34

T63 310

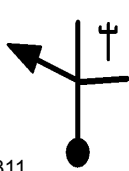



1.25	
	311

1.34	
	312

2.18	
V 36 2.32.20 T64	313

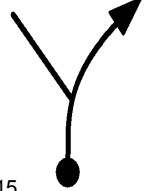
2.61	
	314

2.84	
	315

2.89	
	316

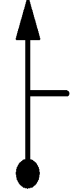
3.28	
	317

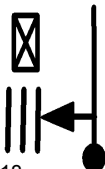
3.90	
	318

4.14	
	319

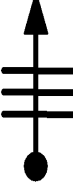
4.30	
	320

4.46	
	321

PELO MEIO DA ROÇA

4.71	
	322

VALO

4.75



323

5.13

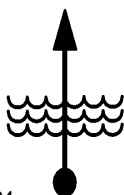

324

5.22

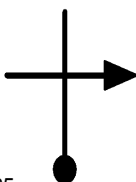

V 39 2.37.24

T65

325

5.76

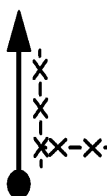

326

CUIDADO GERAL





6.05

Neutro

N 3' 2.38.40

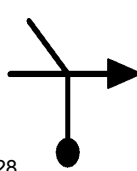
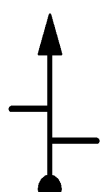
T66

327

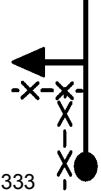
<p>6.05</p> <p>V 39 2.41.40</p> <p>T67</p>	 <p>328</p>
<p>6.41</p>	 <p>329</p>
<p>7.34</p>	 <p>330</p>
<p>7.46</p>	 <p>331</p>
<p>7.96</p>	 <p>332</p>
<p>8.10</p>	 <p>333</p>

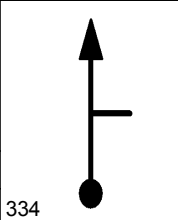
8.47	
	334

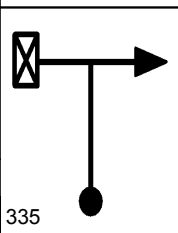

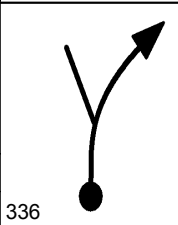

8.63	
V 36 2.45.39	
T68	335

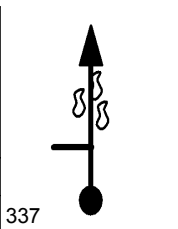
8.81	
	336

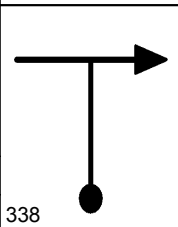
EROSÃO

9.02	
	337

9.17	
	338

<p>9.31</p> <hr/> <hr/>	 <p>339</p>
<p>9.37</p> <hr/> <hr/>	 <p>340</p>
<p>9.40</p> <hr/> <hr/>	 <p>341</p>
<p>9.43</p> <hr/> <hr/>	 <p>342</p>
<p>9.72</p> <hr/> <hr/>	 <p>343</p>
<p>9.91</p> <hr/> <p>N2'30s 2.47.46</p> <hr/> <p>T69</p>	<p>Neutro</p> <p>344</p>

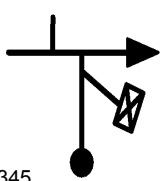
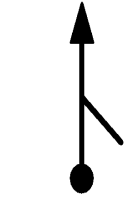
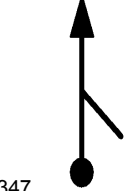
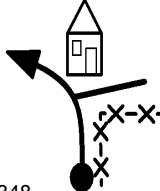
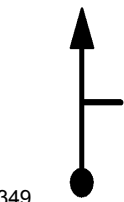
<p>9.91</p> <p>V 39 2.50.16</p> <p>T70</p>	 <p>345</p>
<p>10.27</p> <p>0.00</p> <p>V 39 2.50.50</p> <p>T71</p>	 <p>346</p>
<p>0.12</p>	 <p>347</p>
<p>0.36</p>	 <p>348</p>
<p>0.57</p>	 <p>349</p>

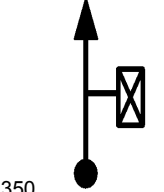
<h1>1.29</h1>	
	350

GERAL CUIDADO!!!

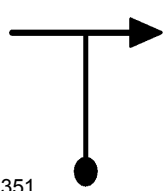
<h1>1.36</h1>	
	351

ATENÇÃO AO CRUZAR!

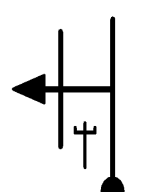
<h1>1.87</h1>	
V 33 2.53.42	
T72	352

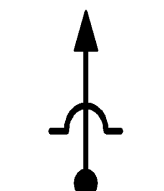
<h1>2.19</h1>	
	353

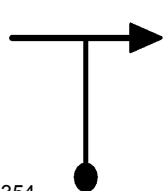
<h1>2.64</h1>	
	354

3.13	Neutro
N 30s 2.56.00	
T73	355

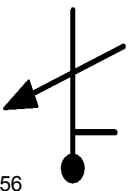
3.13	
V 42 2.56.30	
T74	356

3.35	
	357

3.89	
	358

4.30	
	359



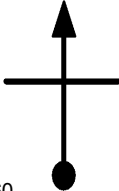

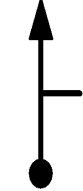
4.64	
	360

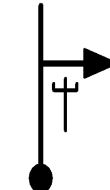
4.92	
	361

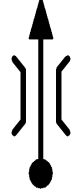

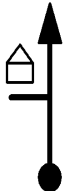

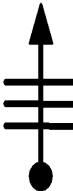

5.15	
V 33 2.59.23	
T75	362

5.23	
	363

5.74	
	364

6.02	
	365

6.06	
	366

<p>6.15</p> <hr/> <hr/>	 <p>367</p>
<p>6.32</p> <p>V 39 3.01.32</p> <p>T76</p>	 <p>368</p>
<p>6.39</p> <hr/> <hr/>	 <p>369</p>
<p>6.43</p> <hr/> <hr/>	 <p>370</p>
<p>6.75</p> <hr/> <hr/>	 <p>371</p>
<p>7.05</p> <hr/> <hr/>	 <p>372</p>

7.25	
	373

7.40	
	374

7.54	
	375

ATENÇÃO!



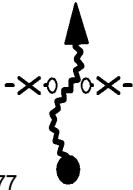

7.61	
	376

NO MATO

7.76	
V 21 3.03.44	377

T77

CUIDADO ROÇA

8.11	
V 36 3.04.45	378
T78	
8.30	
	379
8.56	
	380
8.67	
	381
8.81	
	382

CUIDADO VALO!!!

8.98

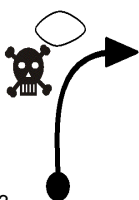

383

CUIDADO GERAL

9.42

Neutro

N3'30s 3.06.56

T79

384

9.42



V 36 3.10.26

T80

385

10.18

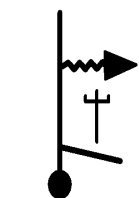

0.00

V 36 3.11.42

T81

386

0.36

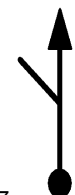

387

CUIDADO PEDRAS

0.47



388

ATENÇÃO

0.63



V 27 3.12.45

T82 389

ATENÇÃO

0.66



390

ATENÇÃO

0.81

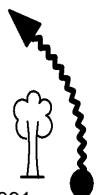

391

ATENÇÃO

0.90



392

CUIDE DA ROÇA

0.99

V 33 3.13.33

T83

393

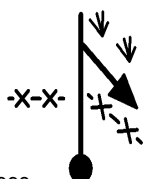

1.10

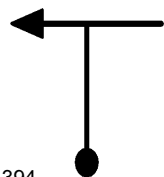

394

1.20



395

1.24

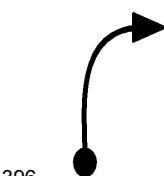

396

NO MATO

1.44

V 21 3.14.22

T84

397



ATENÇÃO

1.48

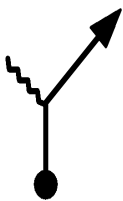

398

NO MATO

1.50



399

CUIDADO EROSÃO

1.63



400

2.21



401

V 33 3.16.33

T85

2.33

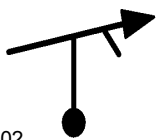

402

2.44	
	403

2.51	
	404

2.78	
	405

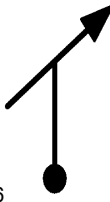
2.86	
	406

2.89	Neutro
N2'30s 3.17.48	
T86	407

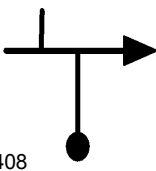
2.89	
V 36 3.20.18	
T87	408

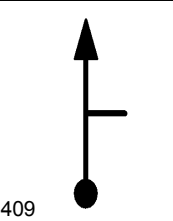
2.99	
	409

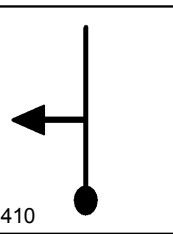
3.35	
	410

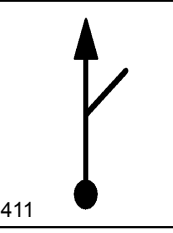
3.61	
	411

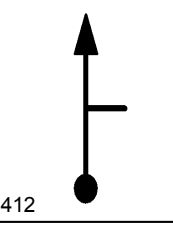
3.99	
	412

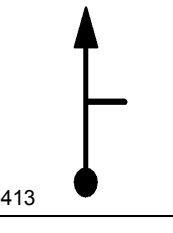
4.34	
	413

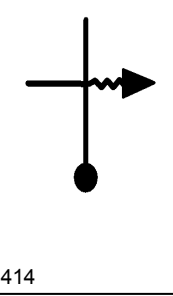
4.46	
0.00	
V 39 3.22.55	
T88	414

0.19	
	415

0.24	
	416

0.46	
	417

0.65	
V 27 3.23.55	
T89	418

1.18	
	419



1.41	
	420

1.67	
	421

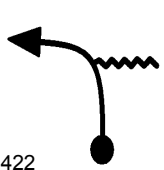
1.93	
V 36 3.26.47	
T90	422

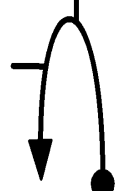
2.14	
	423

2.41	
	424

2.74	Neutro
N 3' 3.28.07	
T91	425

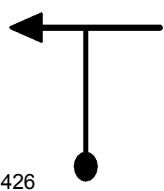
2.74	
V 39 3.31.07	
T92	426

2.89	
	427

3.59	
	428

3.63	
V 36 3.32.29	
T93	429

3.65	
	430

ACELERA!!

3.79	
	431

4.00	
V 33 3.33.07	
T94	432

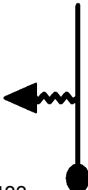
4.53	
V 24 3.34.04	
T95	433

5.26	
	434

5.43	
	435

5.80	
	436

CURVA PERIGOSA!!

6.02	
V 30 3.37.48	
T96	437

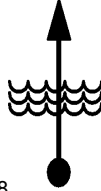
6.41	
	438

6.44	Neutro
Nº30s 3.38.39	
T97	439

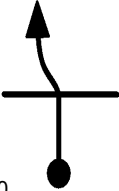
6.44	
V 30 3.43.09	
T98	440

6.72	
	441

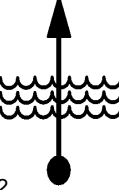
6.75	
	442

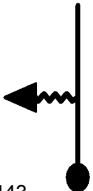
6.79	
	443

6.87	
	444

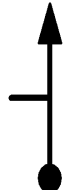
6.92	
	445

7.13	
	446

BURACO PERIGO

7.36	
	447

7.40	
	448

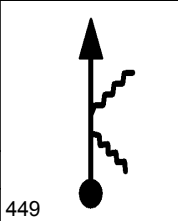
7.60	
	449

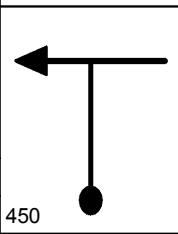
7.64	
	450

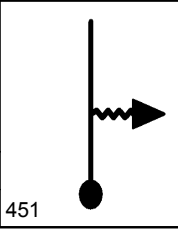
7.70	
	451

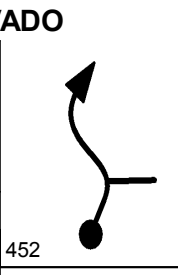
TRAVADO	
7.93	
V 24 3.46.07	
T99	452

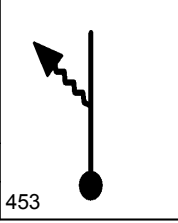
8.04	
	453

8.05	
V 30 3.46.26	
T100	454

8.12	
	455

8.14	
	456

8.28	
	457

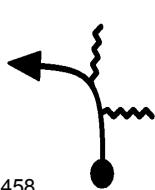
8.36	
	458

SUBIDA COM EROSAO

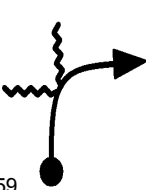
8.48	
	459

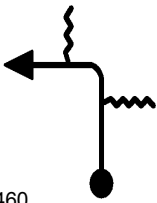
8.57	
	460

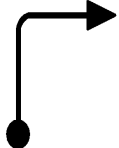
8.82	
	461

8.93	
	462

EROSÕES A FRENTE

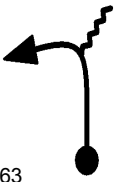
9.00	
V 18 3.48.19	
T101	463

9.27	
V 27 3.49.14	
T102	464

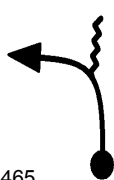
9.49	
	465

9.65	
	466

9.92	
V 24 3.50.41	
T103	467

PERIGO! SIGA PELA DIREITA

10.12	
	468

PELA DIREITA

10.15	
	469

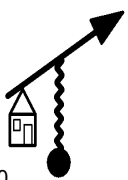
10.35	
	470

10.41	Neutro
N 4' 3.51.54	
T104	471

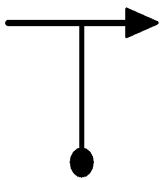
10.41	
0.00	
V 36 3.55.54	
T105	472

0.26	
	473

0.38	
	474

0.55	
	475

0.69	
	476

1.00	
V 36 3.57.34	T106 477

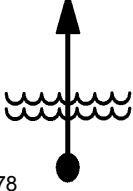
1.10	
	478

1.33	
	479



1.38	
	480

1.45	
V 30 3.58.19	
T107	481

BAMP NO MATO

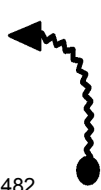
1.48	
	482

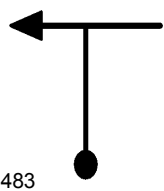
1.50	
	483

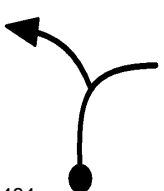
1.91	
	484

CUIDADO TOCO

2.02	
	485

2.42	
	486

2.59	
	487

ATENÇÃO

2.67	
	488

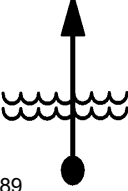
2.70	
	489

2.98	
	490

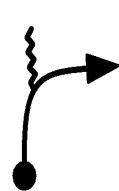
3.11	
	491

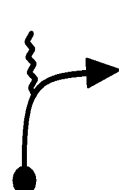
3.30	
	492

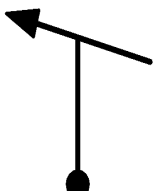
3.39	
	493

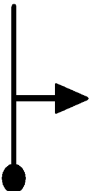
3.53	
	494

3.69	
	495

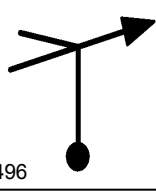
3.70	
	496

3.76	Neutro
N 4' 4.02.56	
T108	497
3.76	
V 36 4.06.56	
T109	498
4.22	
V 39 4.07.43	
T110	499
4.62	
	500
4.92	
	501
5.25	
V 36 4.09.18	
T111	502

5.30	
	503

5.35	
	504

5.59	
	505

5.77	
V 30 4.10.10	
T112	506

SUBIDA COM EROSAO

5.95	
V 33 4.10.31	
T113	507

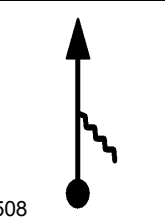
6.08	
	508

6.34	Neutro
N 3' 4.11.14	
T114	509

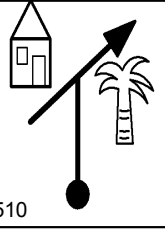
6.34	
V 36 4.14.14	
T115	510

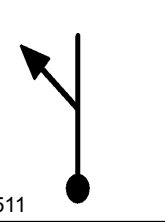
6.46	
	511

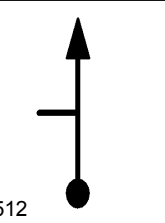
6.57	
	512

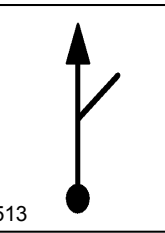
6.59	
	513

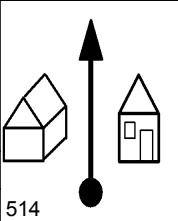
<p>6.83</p>	
	514

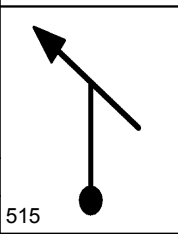
<p>7.28</p>	
	515

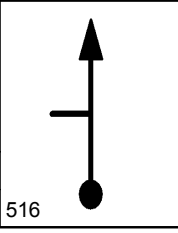
<p>7.62</p>	
	516

CUIDADO GERAL

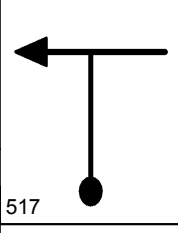
<p>9.03</p>	
V 42 4.18.43	
T116	517

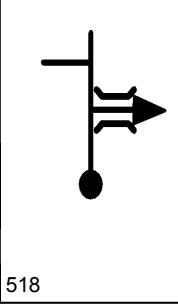
<p>9.26</p>	
0.00	
V 42 4.19.02	
T117	518

0.77	
	519

0.99	
	520

1.14	
	521

PERIGO

1.25	
	522

2.15	
	523

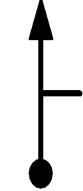
2.21	
	524

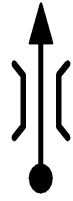
2.38	
	525

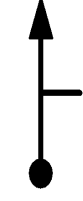
2.75	
	526

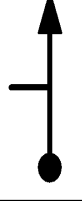
3.25	
	527

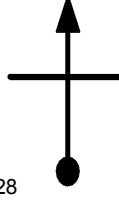
3.98	
	528

4.67	
	529

4.80	
	530

5.20	
	531

5.29	
	532

NÃO ERRE

5.54	
V 36 4.26.57	
T118	533

5.56	
	534

6.15

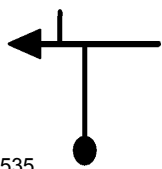

535

6.76



536

6.90

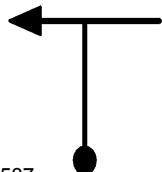

537

7.06



538

7.30

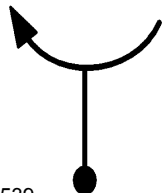

539



7.43

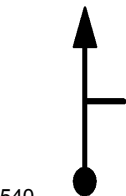

540

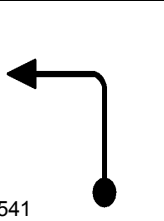
7.58	
	541

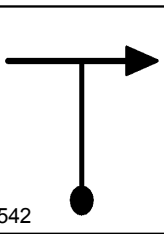
7.63	
	542

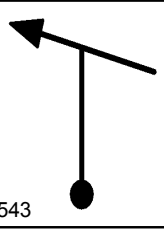
7.86	
V 30 4.30.50	
T119	543

CUIDADO

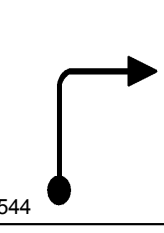
7.97	
	544

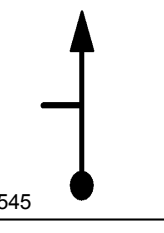
8.05	
	545

EROSOES



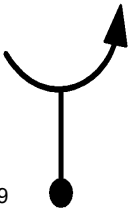

8.15	
	546

8.27	
	547

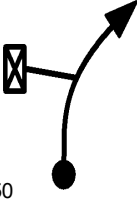
8.33	Neutro
N3'30s 4.31.45	
T120	548

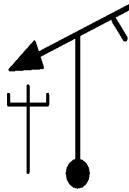
8.33	
V 27 4.35.15	
T121	549

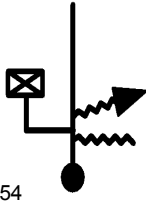
8.56	
	550

<p>8.62</p> <p>0.00</p> <p>V 36 4.35.55</p> <p>T122</p>	 <p>551</p>
<p>0.17</p>	 <p>552</p>
<p>0.55</p>	 <p>553</p>
<p>0.79</p> <p>V 30 4.37.14</p> <p>T123</p>	 <p>554</p>
<p>0.93</p>	 <p>555</p>

1.02	
	556

1.39	
	557

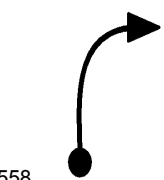
1.60	
	558

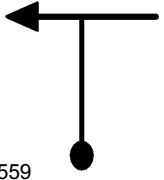
1.87	
	559

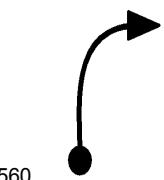
2.09	
	560

2.15	
	561

2.24 Neutro
N2'30s 4.40.08
T124 562

2.24
V 27 4.42.38
T125 563



2.39
564

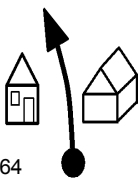

2.46
V 42 4.43.07
T126 565

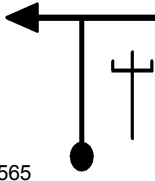

2.65
566



3.08
567

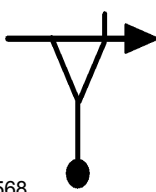

3.29 

568

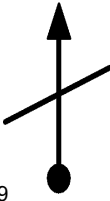
3.40 

569

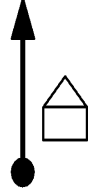
3.61 

570

3.67 

571

3.86 

572

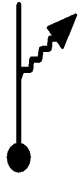
4.13 

V 33 4.45.31

T127 573

4.39	
	574

4.66	
	575

4.69	
	576

ATENÇÃO NO COQUEIRO

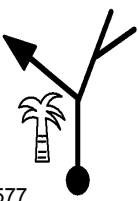
4.71	
V 21 4.46.34	
T128	577

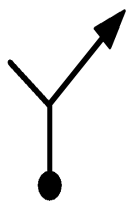
4.73	
	578

4.78	
	579

EROSÕES A FRENTE

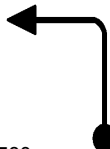
4.82	
	580

5.00	
	581

5.01	Neutro
N 3' 4.47.26	
T129	582

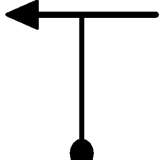
5.01	
V 33 4.50.26	
T130	583

5.25	
	584

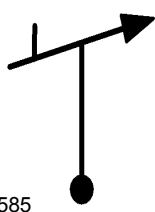
5.35	
V 27 4.51.02 T131	585

5.55	
	586

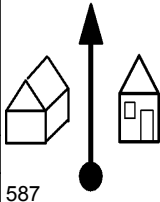
5.63	
	587

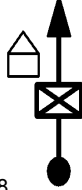
5.78	
	588

5.81	
	589

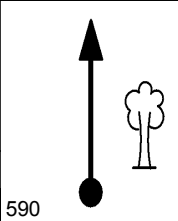
5.89	
V 33 4.52.15	
T132	590

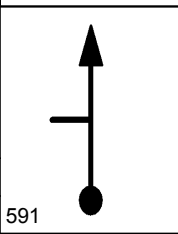
6.00	
	591

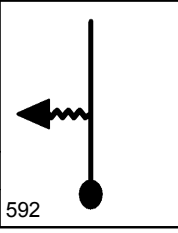
6.39	
	592

ATENÇÃO

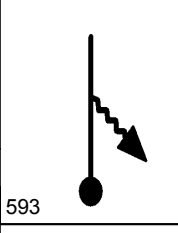
6.63	
V 24 4.53.35	
T133	593

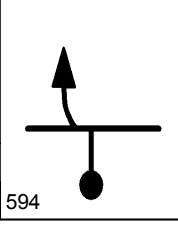
6.80	
V 30 4.54.00	
T134	594

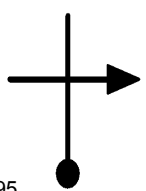
6.92	
	595

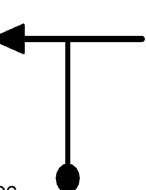
6.99	
	596

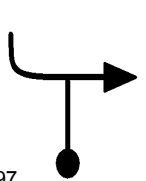
7.16	
	597

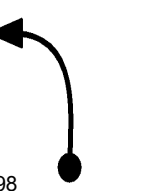
7.21	
	598

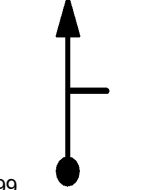
7.24	
	599



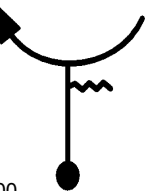

7.70	
	600

<p>7.73</p> <hr/> <hr/>	 <p>601</p>
-------------------------	--------------------------------------------------------------------------------------------

<p>7.84</p> <hr/> <hr/>	 <p>602</p>
-------------------------	----------------------------------------------------------------------------------------------

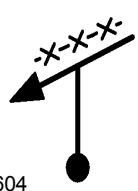
<p>8.01</p> <hr/> <hr/>	 <p>603</p>
-------------------------	----------------------------------------------------------------------------------------------

<p>8.11</p> <hr/> <p>V 36 4.56.37</p> <p>T135</p>	 <p>604</p>
----------------------------------------------------------	-----------------------------------------------------------------------------------------------

<p>8.13</p> <hr/> <hr/>	 <p>605</p>
-------------------------	------------------------------------------------------------------------------------------------

<p>8.19</p> <hr/> <hr/>	 <p>606</p>
-------------------------	------------------------------------------------------------------------------------------------

8.31	
	607

8.41	
	608

8.59	
	609

8.80	
	610

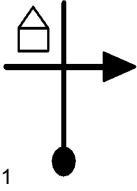
8.83	
V 33 4.57.50	611
T136	

8.93	
	612

9.23 Neutro
N3'30s 4.58.34
T137 613

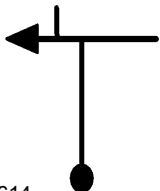

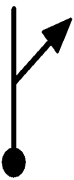

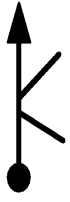
9.23 
V 36 5.02.04
T138 614

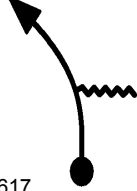
9.49 
615

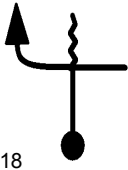
9.59 
616

9.77 
617

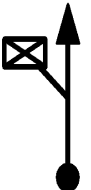
10.07 
618

10.21	
V 27 5.03.41 T139	
619	
10.65	
620	
10.75	Neutro
N 3' 5.04.54 T140	
621	
10.75	
0.00	
V 36 5.07.54 T141	
622	
0.07	
623	

0.15	
	624

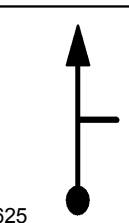
0.63	
	625

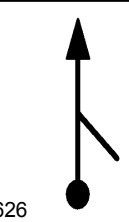
1.02	
	626

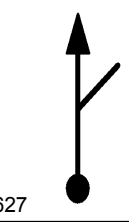
1.44	
	627

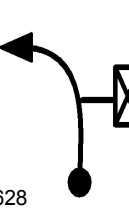
2.97	
V 39 5.12.51 T142	628

3.00	
	629

3.48	
	630

4.05	
	631

4.52	
	632

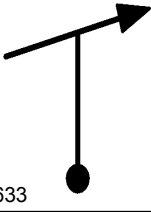
5.05	
V 39 5.16.03 T143	633

5.27	
	634

5.91	
	635

LOCALAMENTO DE PREFERENCIA

<p>5.96</p> <p>D 2' 5.17.28</p> <p>T144</p>	 <p>636</p>
-----------------------------------------------------------	---------------------------------------------------------------------------------------------

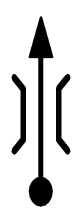
<p>6.14</p>	 <p>637</p>
--------------------	----------------------------------------------------------------------------------------------

2º APOIO URUSSANGA

<p>6.25</p> <p>N 20' 5.19.28</p> <p>T145</p>	<p>Neutro</p> <p>638</p>
------------------------------------------------------------	---------------------------------

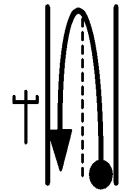
<p>6.25</p> <p>0.00</p> <p>V 42 5.39.28</p> <p>T146</p>	 <p>639</p>
------------------------------------------------------------------------------	-----------------------------------------------------------------------------------------------

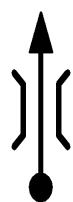
<p>0.08</p>	 <p>640</p>
--------------------	------------------------------------------------------------------------------------------------

DE PREFERENCIA

0.20	 641
------	-----------------------------------------------------------------------------------------

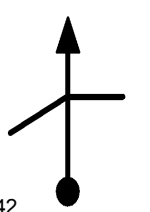
0.25	 642
------	------------------------------------------------------------------------------------------

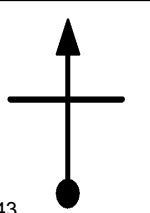
0.47	 643
------	------------------------------------------------------------------------------------------

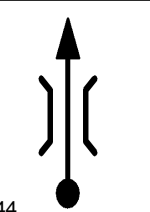
0.99	 644
------	-------------------------------------------------------------------------------------------

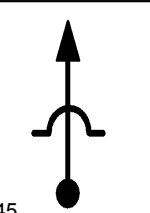
1.49	 645
------	--------------------------------------------------------------------------------------------

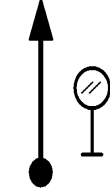
2.52	
	646

3.12	
	647

3.58	
	648

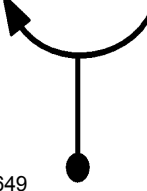
3.60	
	649

4.51	
	650

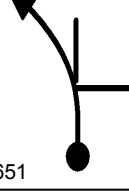
4.75	
	651

4.87	
V 39 5.46.26	
T147	652

5.02	
	653

5.18	
	654

5.39	
V 33 5.47.14	
T148	655

COSTEAR PELA DIREITA

5.49	
	656

5.89	
	657

6.06	
	658

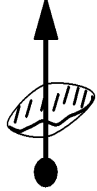
6.29	
	659

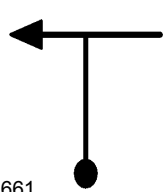

6.60	
	660

7.13	
	661

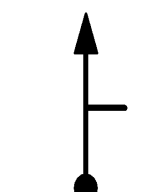
7.28	
	662

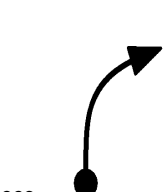
7.60	
	663

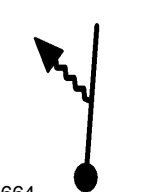
7.75	
	664

NO EUCALIPTO

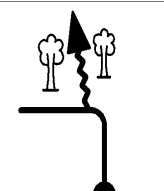
7.84	
	665

7.86	
	666

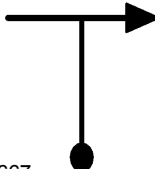
8.11	
	667

8.14	Neutro
N2'30s 5.52.13	
T149	668

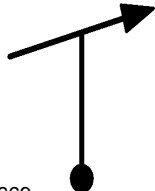
8.14	
V 36 5.54.43	
T150	669

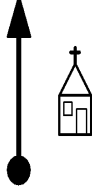
8.48	
	670

ATENÇÃO

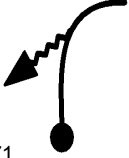
8.54	
V 18 5.55.23	
T151	671

CUIDADO VALO

8.97

0.00

V 27 5.56.50

T152 672

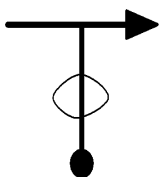

PELO LADO

0.12



673

0.19

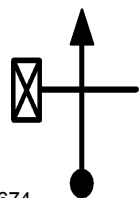

674

0.46

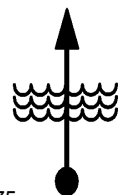

675

1.17

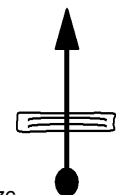

676

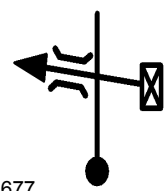
1.19	
	677

1.21	Neutro
N 3' 5.59.32	
T153	678

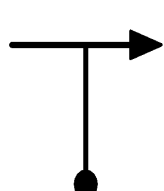
1.21	
V 36 6.02.32	
T154	679

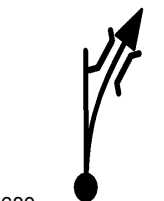
1.69	
	680

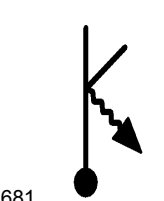
2.17	
V 36 6.04.08	
T155	681

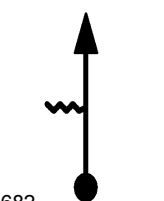
2.38	
	682

2.42	
	683

2.55	
	684

2.66	
V 30 6.04.57	
T156	685

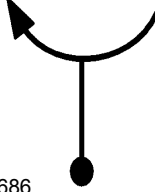
COSTEAR BARRANCO	
2.70	
	686

SUBA	
2.76	
	687

2.83	
	688

BURACO PERIGO

2.92	
	689

3.28	
V 36 6.06.11	
T157	690

3.52	
	691

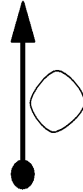
4.15	
	692

4.35

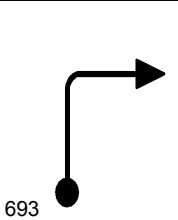

693

ABISMO A FRENTE

4.38

Neutro

N2'30s 6.08.00

T158

694

4.38

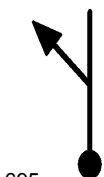

V 27 6.10.30

T159

695

4.50

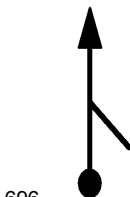

696

PERIGO ABISMO

4.55



697

PERIGO

4.60	 698

4.64	 699
V 33 6.11.06 T160	

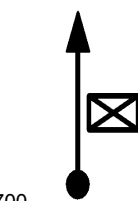
5.02	 700

5.08	Neutro
N 2' 6.11.54 T161	

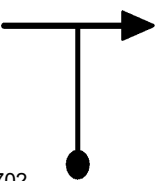
5.08	 702
V 42 6.13.54 T162	

5.23

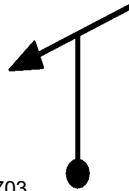

703

5.86

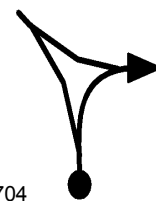

704

6.07

V 36 6.15.18

T163



705

6.31

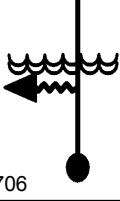

706

6.50

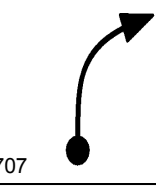

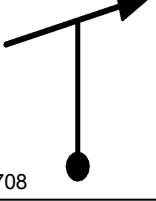

707

6.54





708

<p>6.68</p> <p>_____</p> <p>_____</p>	 <p>709</p>
---------------------------------------	---------------------------------------------------------------------------------------------

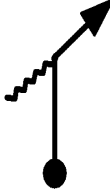
<p>6.72</p> <p>_____</p> <p>_____</p>	 <p>710</p>
---------------------------------------	----------------------------------------------------------------------------------------------

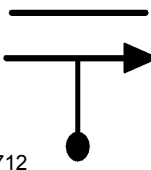
<p>6.75</p> <p>_____</p> <p>_____</p>	 <p>711</p>
---------------------------------------	----------------------------------------------------------------------------------------------

<p>7.00</p> <p>_____</p> <p>_____</p>	 <p>712</p>
---------------------------------------	-----------------------------------------------------------------------------------------------

<p>7.08</p> <p>_____</p> <p>_____</p>	 <p>713</p>
---------------------------------------	------------------------------------------------------------------------------------------------

<p>7.11</p> <p>N 2' 6.17.03</p> <p>T164</p>	<p>Neutro</p> <p>714</p>
----------------------------------------------------	--------------------------

7.11	
V 42 6.19.03	
T165	715

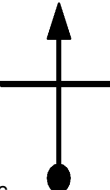
7.46	
	716

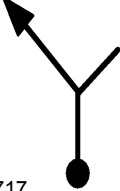
7.64	
	717

7.81	
	718

7.85	
	719





7.89	
	720

7.96	
	721

8.67	
0.00	
V 42 6.21.17	
T166	722

0.07	
	723

0.70	
	724

1.47	
	725

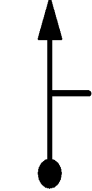
1.99	
	726

2.18	
V 27 6.24.23	
T167	727

2.23	
	728

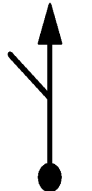
2.30	
	729

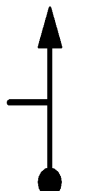
2.86	
	730

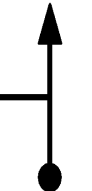
3.16	
	731

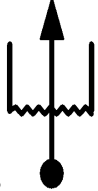
3.38	
V 39 6.27.03	
T168	732

3.70	
	733

4.10	
	734

ATENÇÃO

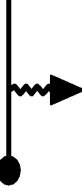
4.83	
V 30 6.29.17	
T169	735

5.27	
0.00	
V 30 6.30.10	
T170	736

PELA ESQUERDA

0.17	
	737

0.48	
	738

CURVA PERIGOSA

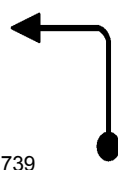
0.68	
	739

1.02	
	740

1.23	Neutro
N2'30s 6.32.38	
T171	741

1.23	
V 42 6.35.08	
T172	742

1.29	
	743

2.27	
0.00	
V 42 6.36.37	
T173	744

0.40	
	745

1.25	
	746

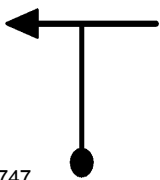
1.69	
	747

2.41	
	748

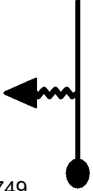
2.86	
V 30 6.40.42 T174	749

2.95	
	750

CUIDADO ARVORE

3.19	
	751

DESCIDA PERIGOSA ABISMO

3.39	Neutro
N 2' 6.41.46	
T175	752

3.39	
V 15 6.43.46	
T176	

ABISMO

3.60	

3.95	
V 30 6.46.00	
T177	

NAO ERRE

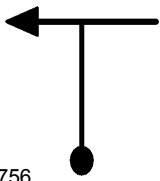
4.03	

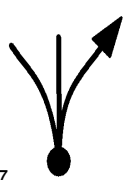
4.04	
	757

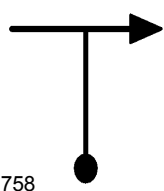
4.19	
	758

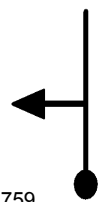
4.21	
V 27 6.46.31	
T178	759

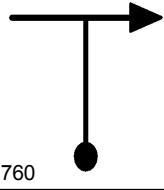
4.59	
	760

4.75	
	761

5.00	
	762

5.12

763

5.20

764

5.30 Neutro

N 3' 6.48.57

T179 765

5.30

V 36 6.51.57

T180 766





5.33

767

5.73

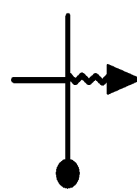
V 33 6.52.40

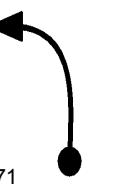
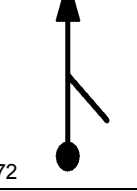
T181 768

5.88	
0.00	
V 33 6.52.56	
	T182 769
0.20	
	770
0.39	
	771
0.42	
	772
0.51	
	773

0.73	
	774

0.86	Neutro
N 2' 6.54.30	
T183	775

0.86	
V 42 6.56.30	
T184	776

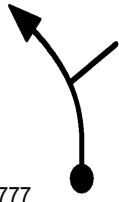
1.07	
	777

1.26	
	778

1.38	
	779



1.60	

780

1.76	
V 27 6.57.48	

T185

781

1.82	

782

1.89	

783

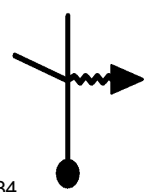
2.52	
	784

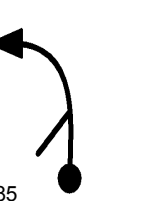
2.82	
	785

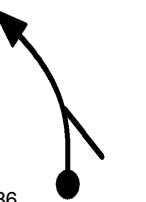
2.85	
	786

2.99	
	787

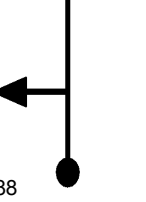
3.05	
	788

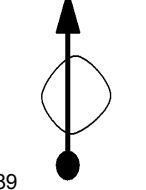
3.23	
V 33 7.01.03	
T186	789

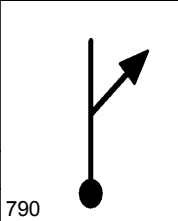
3.36	
	790

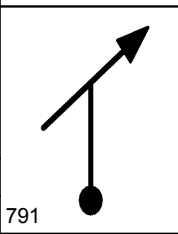
3.46	
	791

3.55	Neutro
N 3' 7.01.38	
T187	792

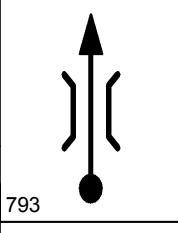
3.55	
V 27 7.04.38	
T188	793

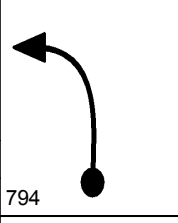
3.87	
	794

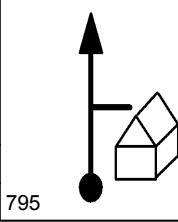
3.94	
	795

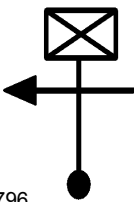
4.03	
V 39 7.05.43	
T189	796

4.07	
	797

4.38	
	798

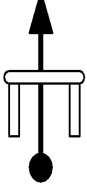
4.58	
	799

4.61	
V 33 7.06.36	
T190	800

4.69	
	801

<p>4.77</p>	 <p>802</p>
-------------	---------------------------------------------------------------------------------------------

<p>4.89</p>	 <p>803</p>
-------------	----------------------------------------------------------------------------------------------

<p>5.28</p>	 <p>804</p>
-------------	----------------------------------------------------------------------------------------------

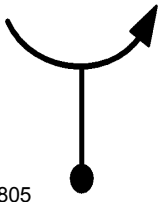
<p>5.53</p>	 <p>805</p>
-------------	-----------------------------------------------------------------------------------------------

<p>5.56</p>	<p>Neutro</p>
<p>N2'30s 7.08.20</p>	<p>806</p>
<p>T191</p>	

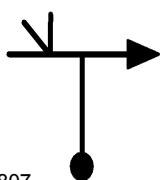
<p>5.56</p>	 <p>807</p>
<p>V 39 7.10.50</p>	
<p>T192</p>	

6.06	
	808

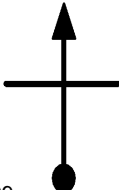
6.42	
	809

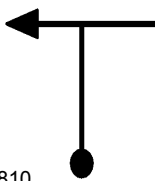
7.12	
V 42 7.13.13	
T193	810

7.93	
	811

8.58	
	812

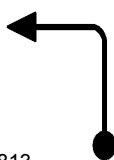
8.91	
	813

9.12	
	814

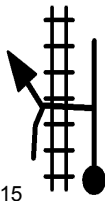
9.41	
	815

EM DIREÇÃO A PONTE

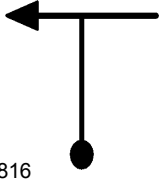
9.46	
	816

9.48	
	817

9.55	
	818

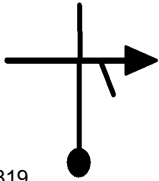
10.17	
	819

10.60	
	820

10.88	
	821

11.19	
	822

11.35	
	823

11.60	
	824

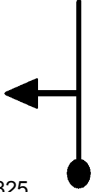
11.63	
	825

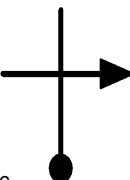
11.88	
	826

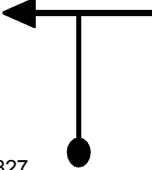
12.04	
	827

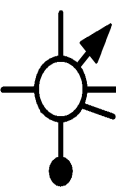
SAIA DO ASFALTO	
12.26	
0.00	
V 42 7.20.34	
T194	828

0.49	
	829

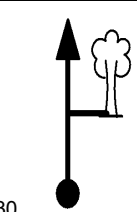
1.25	
	830

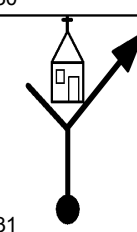
1.67	
	831

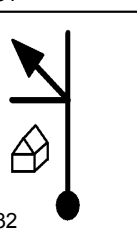
2.00	
V 36 7.23.25	
T195	832

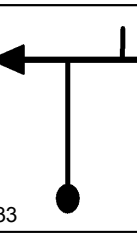
2.33	
V 39 7.23.58	
T196	833

2.55	
	834

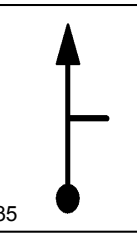
2.91	
	835

3.15	Neutro
NI'30s 7.25.14	
T197	836

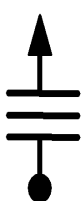
3.15	
V 27 7.26.44	
T198	837

RESPEITE OS MORADORES

3.35	
	838

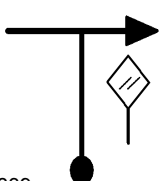
3.38	
V 42 7.27.15	
T199	839

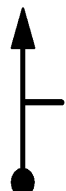

4.00	
	840

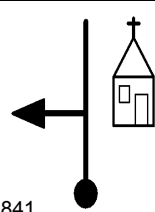
5.08	
	841

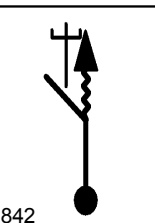
5.80	
V 36 7.30.43	
T200	842

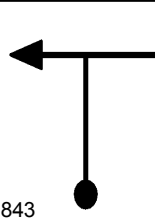
6.08	
	843

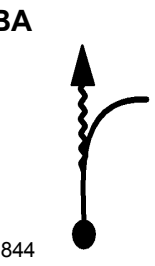
SUBA	
6.26	
V 39 7.31.28	
T201	844

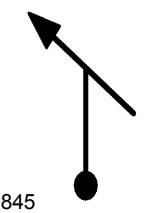
6.30	
	845

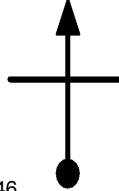
6.35	
	846

6.61	
	847

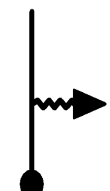
6.94	
V 36 7.32.31	848
T202	

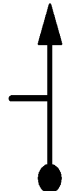
7.12	
	849

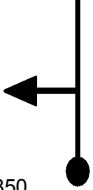
7.16	
	850

7.30	
	851

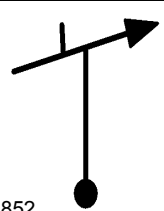
7.32	
	852

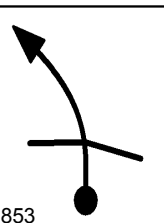
7.52	
	853

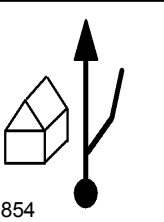
7.75	
	854

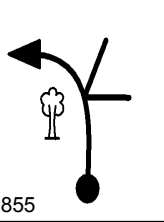
7.99	
	855

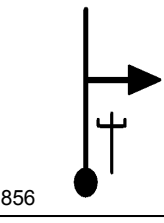
8.14	
	856

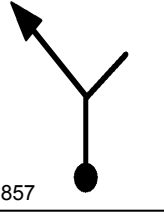
8.22	
	857

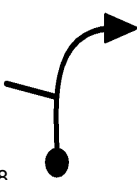
8.41	
	858

8.45	
	859

8.54	
	860

ATENÇÃO

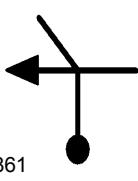
8.67	
	861

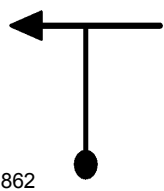
8.84	
	862

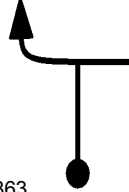
8.98	
	863

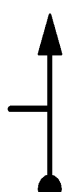
9.18	
	864

ATENÇÃO

9.33	
	865

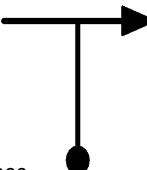
9.49	
	866

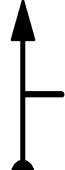
9.57	
	867

9.86	
V 30 7.37.23	
T203	868

9.93	
	869

CUIDADO PEDRAS

10.21	
	870

10.42	
V 36 7.38.30	
T204	871

10.63	
	872

10.77
N3'30s 7.39.06
T205 873

Neutro

10.77
V 39 7.42.36
T206 874



11.05
875



11.45
876

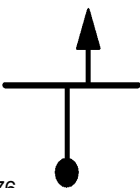





11.84
877

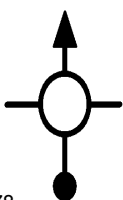

UNIDAD TREVO MOVIMENTADO

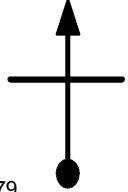
11.94
878



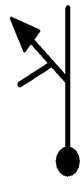

<p>12.39</p>	 <p>879</p>
<p>12.66</p>	 <p>880</p>
<p>13.00</p>	 <p>881</p>
<p>13.32</p>	 <p>882</p>
<p>13.46</p> <p>0.00</p> <p>V 33 7.46.44</p> <p>T207</p>	 <p>883</p>

0.18	
	884

ATENÇÃO!!! BAMP

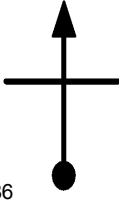
0.32	
	885

0.38	
	886

0.40	
	887

0.52	
	888

0.71	
	889

0.75	
	890

0.84	
	891

0.99	
	892

1.02	
	893

ATENÇÃO	
1.14	
	894

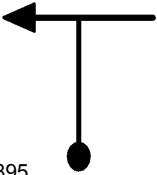
1.28	
	895

1.58	
	896

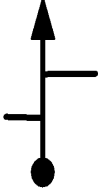
1.61	
	897

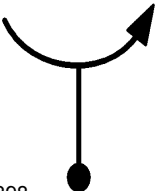
1.63	
	898

1.80	
	899

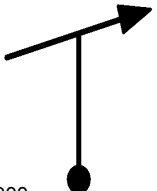

1.92	
	900

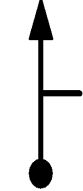
1.94	
	901

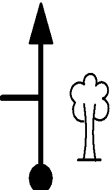
2.00	
	902

2.37	Neutro
N°30s 7.51.03	
T208	903

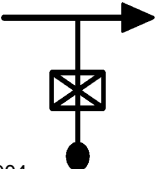
2.37	
V 39 7.55.33	
T209	904

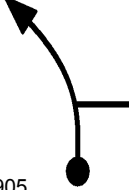
2.55	
	905

2.93	
	906

RUA PERIGOSA CUIDADO!!!

3.44	
	907

3.88	
	908

4.43	
	909

4.76	
	910

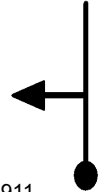
4.79	
V 33 7.59.16	
T210	911

4.81

912



4.82

913



5.16

914



5.73

915



5.78

916



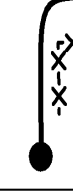

5.79

917

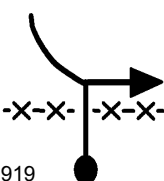

5.91	Neutro
N2'30s 8.01.18	
T211	918



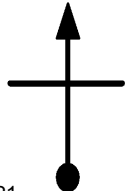

5.91	
V 36 8.03.48	
T212	919

6.19	
	920

6.41	
	921

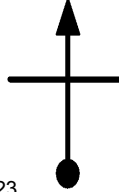
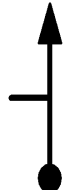
CUIDADO RUA MOVIMENTADA

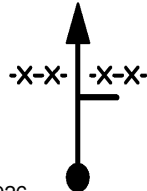
6.69	Neutro
N 1' 8.05.07	
T213	922

<p>6.69</p> <p>V 39 8.06.07</p> <p>T214</p>	 <p>923</p>
<p>7.06</p>	 <p>924</p>
<p>7.40</p>	 <p>925</p>
<p>7.63</p> <p>V 39 8.07.33</p> <p>T215</p>	 <p>926</p>
<p>7.76</p>	 <p>927</p>
<p>7.85</p>	 <p>928</p>

7.99	
	929

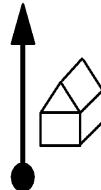
8.16	
	930

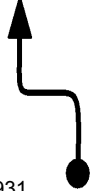
8.33	
	931

8.69	
	932

8.81	
	933

8.87	
	934

8.98	
	935

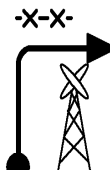
9.02	
	936

9.33	
0.00	
V 39 8.10.10	
T216	937

0.08	
	938

COSTEAR A CERCA

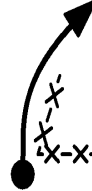
0.18	
	939

0.49	
	940

0.52	
	941

1.06	Neutro
N 2' 8.11.48	
T217	942

1.06	
0.00	
V 39 8.13.48	
T218	943

0.27	
	944

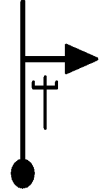
0.70	
	945

1.08	
	946

NO MATO

1.26	
V 36 8.15.45	
T219	947

1.41	
	948

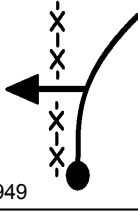
1.63	
	949

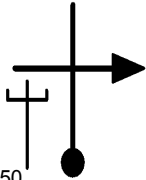
1.67	
V 51 8.16.26	
T220	950

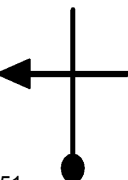
1.73	
	951

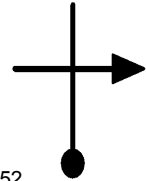
1.91	
	952

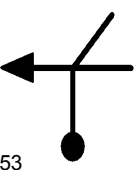
1.97	
	953

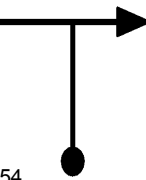
2.19	
	954

2.23	
	955

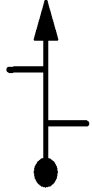
2.66	
	956

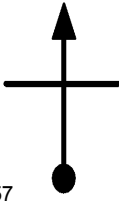
2.80	
	957

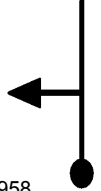
3.03	
	958

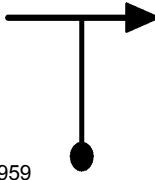
3.15	
	959



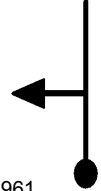

3.27	
	960

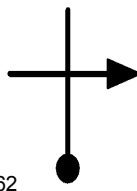
3.30	
	961

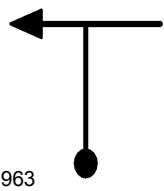
3.52	
	962

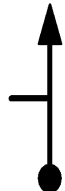
3.58	
	963

3.92	
	964

4.15	
	965

CUIDADO ASFALTO	
4.41	Neutro
N 4' 8.19.39	
T221	966

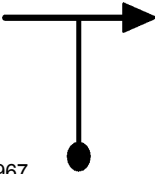
4.41	
V 45 8.23.39	
T222	967

4.72	
	968

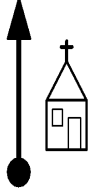
4.94	
	969

5.47	
	970

TRILHO

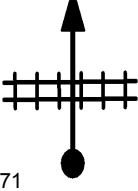
5.98	
	971

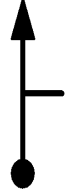
6.90	
972	

CUIDADO AO ATRAVESSAR

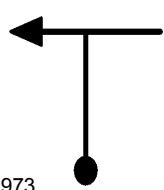
7.40	
973	

3º APOIO FORQUILHINHA

7.43	Neutro
N 20' 8.27.41	
T223 974	

7.43	
0.00	
V 42 8.47.41	
T224 975	

0.38	
976	

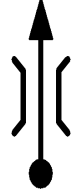
<p>0.63</p>	
	977

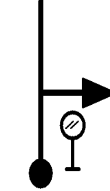

<p>1.29</p>	
	978



<p>1.69</p>	
	979

<p>2.05</p>	
	980

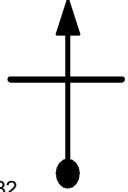
CUIDAD PARA CRUZAR

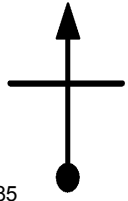
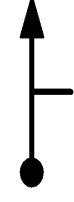
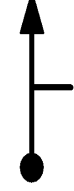
<p>2.86</p>	<p>Neutro</p>
<p>N 1' 8.51.46</p>	
<p>T225</p>	981

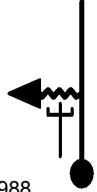
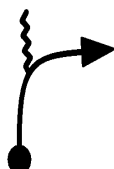
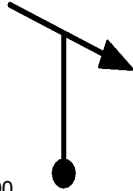
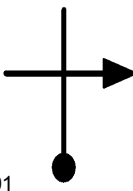
<p>2.86</p> <p>V 39 8.52.46</p> <p>T226</p>	 <p>982</p>
<p>3.69</p>	 <p>983</p>
<p>3.94</p>	 <p>984</p>
<p>4.15</p>	 <p>985</p>
<p>5.00</p>	 <p>986</p>
<p>5.26</p>	 <p>987</p>

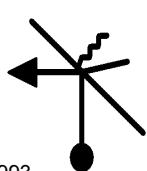
<p>5.36</p> <p>V 33 8.56.36</p> <p>T227</p>	 <p>988</p>
<p>5.49</p>	 <p>989</p>
<p>5.72</p>	 <p>990</p>
<p>5.82</p>	 <p>991</p>
<p>5.96</p>	 <p>992</p>
<p>6.06</p>	 <p>993</p>

6.09	
	994

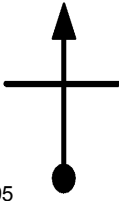
6.19	
	995

6.31	
	996

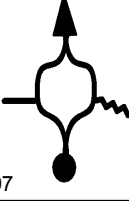
6.42	
	997

ENTRE NO RIO

6.45	
V 15 8.58.36	
T228	998

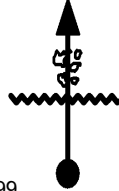
6.47	
	999

DESÇA DEGRAU

6.58	
	1000



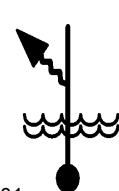

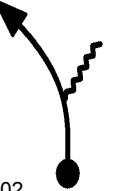
SAIR DO RIO

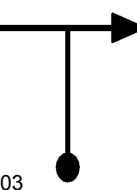
6.64	
	1001

6.66	
	1002

6.70	
V 39 8.59.35	1003

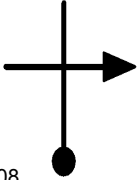
T229

6.95	
6.97	
7.24	
7.40	Neutro
N3'30s 9.00.40	T230
7.40	
V 39 9.04.10	T231
7.82	
V 33 9.04.49	T232

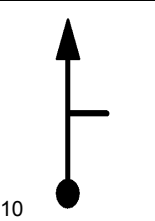
7.93	
	1010

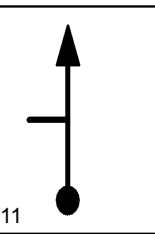
8.16	
	1011

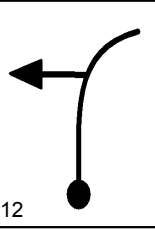
8.18	
	1012

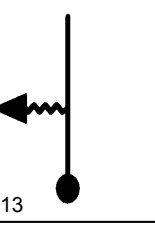
8.39	
	1013

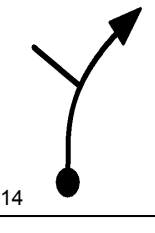
8.48	
	1014

8.67	Neutro
N 2' 9.06.22	
T233	1015

CUIDADO ESTRADA GERAL

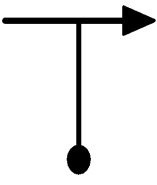
8.67	
0.00	
V 39 9.08.22	
T234 1016	

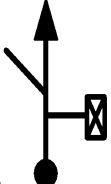
0.06	
1017	

SUBA

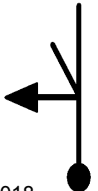
0.26	
V 39 9.08.46	
T235 1018	

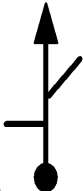
0.34	
1019	





0.64	
1020	

0.94	
	1021

ATENÇÃO!!

1.06	
V 36 9.10.00	
T236	1022

1.07	
	1023

1.13	
	1024

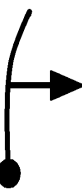
1.22	
	1025

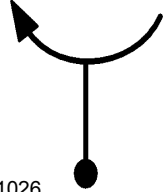
1.37	
	1026

1.39	
	1027

1.46	
	1028

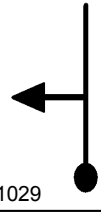
1.53	
	1029

1.55	
	1030

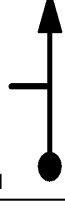
1.64	
	1031

1.67	
	1032

1.91	
V 33 9.11.25	
T237	1033

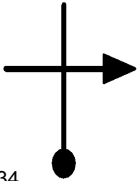
1.94	
	1034

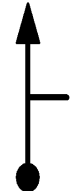
1.96	
	1035

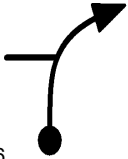
2.02	
	1036

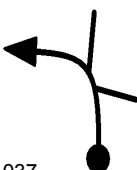
2.06	
	1037

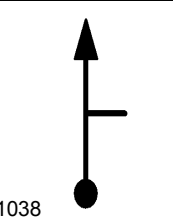
2.09	
	1038

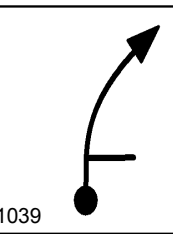
2.13	
	1039

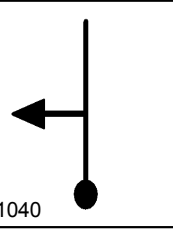
2.19	
	1040

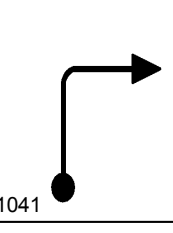
2.21	
	1041

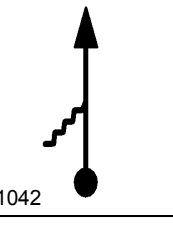
2.24	
	1042

2.44	Neutro
N 2' 9.12.23	
T238	1043

2.44	
V 36 9.14.23	1044

2.66	
	1045

PELO MEIO LAJE

3.02	
	1046

3.25	
	1047

3.28	
	1048

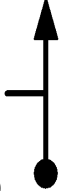
3.37	
	1049

3.41	
	1050

RAIZ

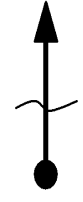
3.46	
	1051

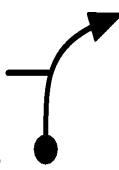
3.55	
	1052

3.56	
	1053

3.58	
	1054

3.65	
	1055

3.68	
	1056

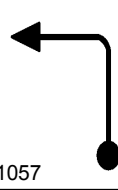
3.71	
	1057

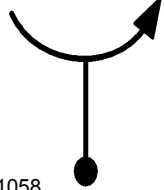
3.73	
	1058

3.79	
	1059

3.83	
	1060

3.86	
	1061

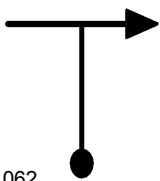
3.87	
	1062

3.95	
	1063

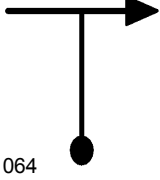
3.99	
	1064

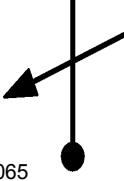
4.03	
	1065

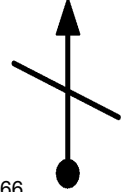
4.05	
	1066

4.08	
	1067

4.10	Neutro
N 4' 9.17.09	
T240	1068

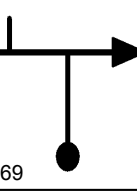

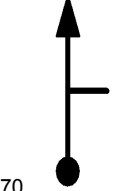
4.10	
V 42 9.21.09	
T241	1069

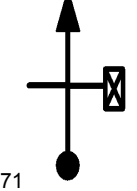
4.33	
	1070

4.59	
	1071

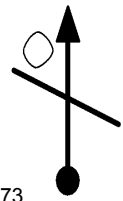
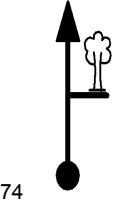
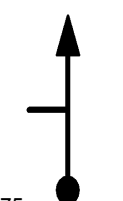
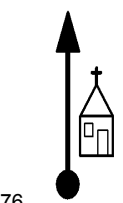
PARE RUA MOVIMENTADA

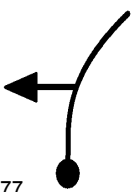
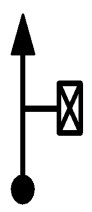
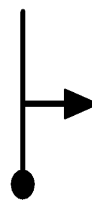
5.04	Neutro
N 30s 9.22.29	
T242	1072
5.04	
V 42 9.22.59	
T243	1073
5.49	
	1074
5.83	
	1075
6.50	
	1076

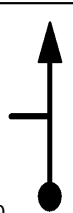
6.77	
	1077
7.10	
	1078
7.25	
V 36 9.26.09	1079
T244	
	
7.30	
	1080

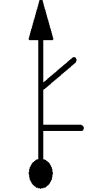
7.37	
	1081

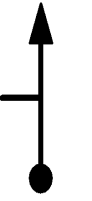

7.50	
	1082

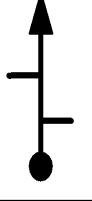
7.67	
	1083

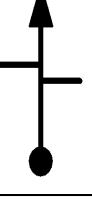
7.80	
	1084

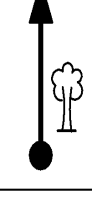
7.89	
	1085

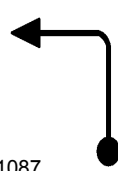
8.00	
	1086

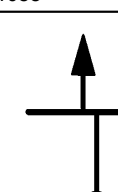
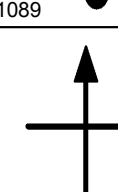
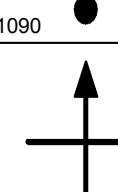
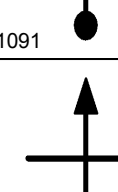
8.05	
	1087
8.11	
	1088
8.18	
	1089
8.44	
	1090
8.47	
	1091
8.50	
	1092

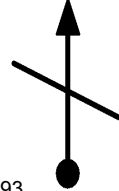
8.55	
	1093

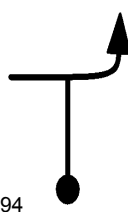
8.61	
	1094

8.66	
	1095

8.77	
	1096

BARRANCO

8.90	
	1097

8.99	
	1098

9.07	
	1099

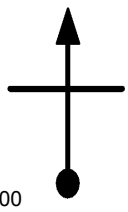

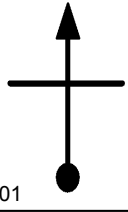
9.10	
	1100

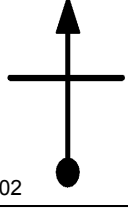

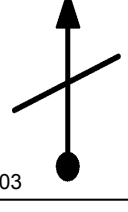
9.13	
	1101

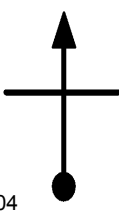
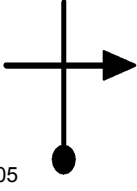

9.20	
	1102

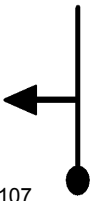
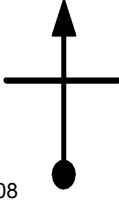
9.35	
	1103

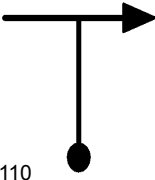
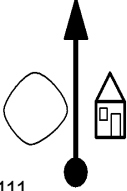
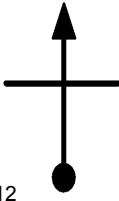
DESCE

9.38	
	1104
9.43	
	1105
9.53	
	1106
9.60	
	1107
9.62	
	1108

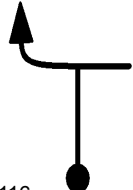
9.80	Neutro
N 3' 9.30.24	
	T245 1109
9.80	
V 30 9.33.24	
	T246 1110
10.08	
	1111
10.16	
V 36 9.34.06	
	T247 1112
10.38	
	1113
10.41	
	1114

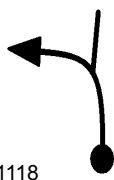
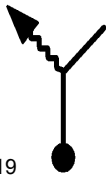
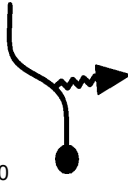
10.46	
10.61	
10.66	
10.75	
10.82	
V 30 9.35.13 T248	

1115

1116

1117

1118

1119

1120

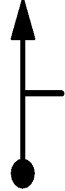
11.06	
	1121

11.14	Neutro
N 3' 9.35.52	
T249	1122

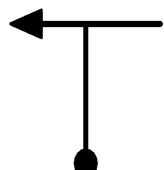
11.14	
V 39 9.38.52	
T250	1123

11.35	
	1124

11.98	
0.00	
V 39 9.40.09	
T251	1125

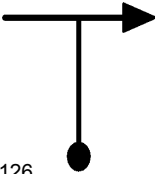
0.05	
	1126

MUITO CUIDADO!!

0.25	Neutro
N 30s 9.40.32	
T252	1127

0.25	
V 36 9.41.02	
T253	1128

ATRAVESSAR VIADUTO

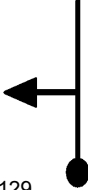
0.35	
	1129

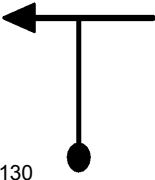
0.41	
	1130

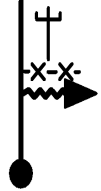
0.52	
V 36 9.41.29	
T254	1131

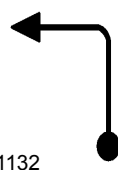
0.68	
	1132

0.70	Neutro
N 30s 9.41.47	
T255	1133

CUIDADO ESTRADA GERAL

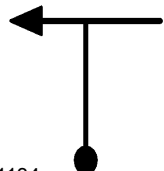
0.70	
V 36 9.42.17	
T256	1134

0.72	
	1135

0.82	
	1136

0.92	
	1137

0.98	
	1138

CUIDADO ESTRADA GERAL

1.13	Neutro
N 30s 9.43.00	
T257	1139

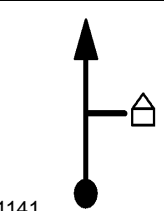

1.13	
V 42 9.43.30	
T258	1140

1.72	
	1141

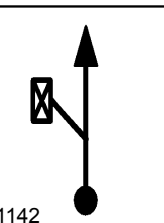
1.99	
	1142

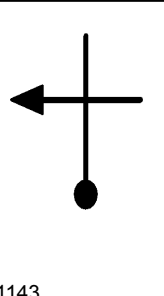
2.31	
0.00	
V 36 9.45.11	
T259	1143

RESPEITE A ROÇA

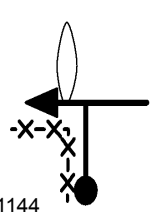
0.40	
	1144

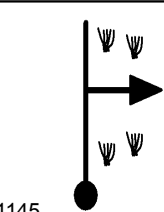
0.42	
	1145

COSTEAR VALO

0.46	
	1146

1.06	
	1147

1.44	Neutro
NI'30s 9.47.36	
T260	1148

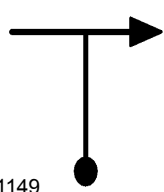
1.44	
V 36 9.49.06	
T261	1149

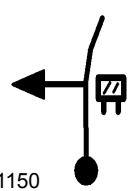
2.16	
	1150

3.09	
	1151

TRILHA ESCONDIDA

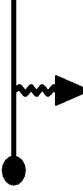
3.35	
V 21 9.52.17	
T262	1152

3.56	
	1153

3.73	
	1154

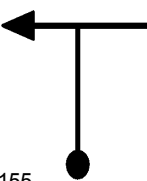
3.95	
	1155

4.07	
	1156

CUIDADO ROÇA RESPEITE

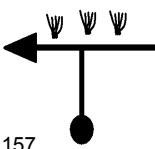
4.19	
V 36 9.54.40	
T263	1157

RESPEITE A ROÇA

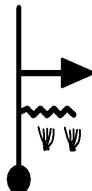
4.29	
	1158

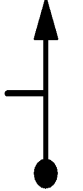
4.68	
	1159

4.87	
	1160

CUIDADO ESTRADA GERAL

4.92	Neutro
N 3' 9.55.53	
T264	1161

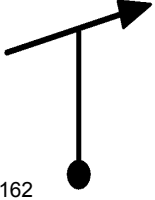
4.92	
V 42 9.58.53	
T265	1162

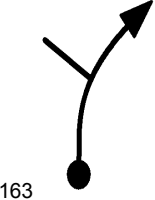
5.11	
	1163

PENITENCIARIA

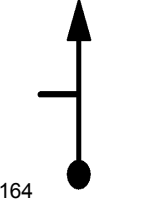
5.22	
	1164

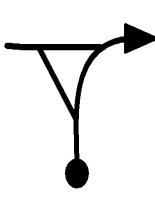
5.76	
0.00	
V 39 10.00.05	
T266	1165

0.70	
	1166

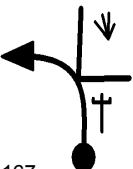
1.10	
	1167

1.52	
V 33 10.02.26	
T267	1168

COSTEAR O MATO

1.62	
	1169

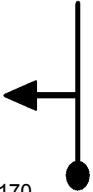
1.84	
	1170

COSTEAR O VALO

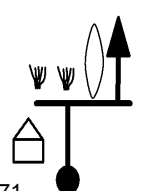
1.89	
	1171

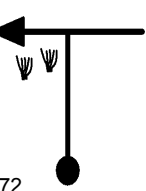
2.00	
	1172

NO MATO

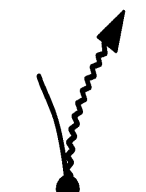
2.03	
V 30 10.03.21	
T268	1173

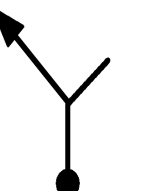
2.57	
	1174

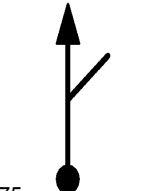
2.61	
	1175

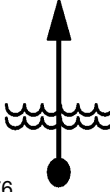
2.65	
	1176

COSTEAR A ROÇA E MATO

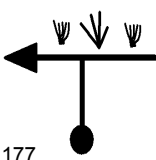
2.73	
V 33 10.04.45	
T269	1177

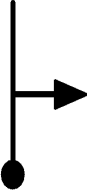
2.97	
	1178

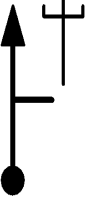
3.06	
	1179

3.18	
	1180

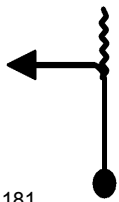
3.22	
	1181

ATENÇÃO

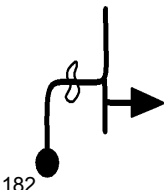
3.30	
	1182

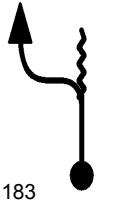
3.55	
	1183

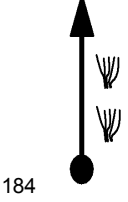
3.60	
	1184

3.74	Neutro
N3'30s 10.06.35	
T270	1185

3.74	
V 27 10.10.05	
T271	1186

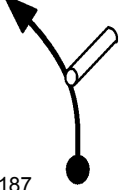

CUIDE DA GRAMA

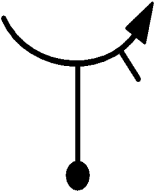
3.78	
	1187

3.83	
0.00	
V 42 10.10.17	
T272	1188

0.27	
	1189

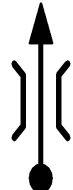
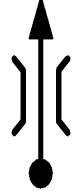
0.91	
	1190

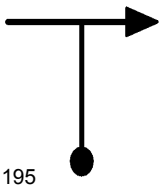
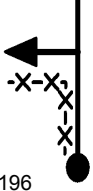
<p>1.45</p> <hr/> <hr/>	 <p>1191</p>
<p>1.88</p> <hr/> <hr/>	 <p>1192</p>
<p>2.16</p> <hr/> <hr/>	 <p>1193</p>
<p>2.85</p> <hr/> <hr/>	 <p>1194</p>
<p>3.36</p> <hr/> <hr/>	 <p>1195</p>
<p>3.49</p> <hr/> <p>V 33 10.15.17</p> <p>T273</p>	 <p>1196</p>

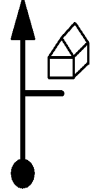
3.88	
V 42 10.16.00	
T274	1197

4.37	
	1198

HORA DE LIMPAR A VELA

4.75	Neutro
N30s 10.17.14	
T275	1199

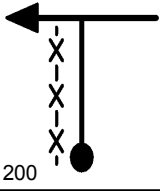

4.75	
V 51 10.17.44	
T276	1200

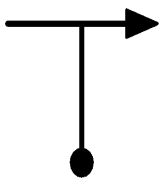
4.85	
0.00	
V 51 10.17.51	
T277	1201

0.13	
	1202

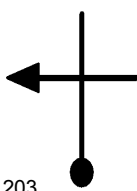
0.48	
	1203

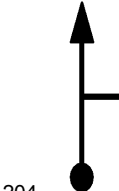
0.60	
	1204

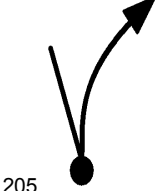
0.73	
	1205

0.77	
	1206

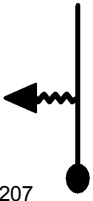
0.87	
	1207

1.28	
	1208

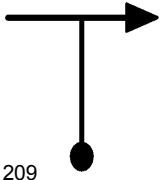
1.69	
	1209

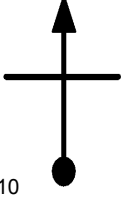
2.40	
	1210

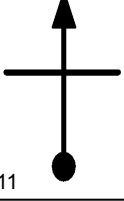
2.57	
	1211

2.82

1212

2.92

1213

3.34

1214

3.75





1215

3.93

1216

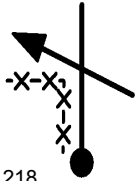
4.01

1217

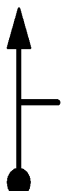
<p>4.21</p>	 <p>1218</p>
<p>4.34</p>	 <p>1219</p>
<p>4.67</p> <p>0.00</p> <p>V 57 10.23.21</p> <p>T278</p>	 <p>1220</p>
<p>0.16</p>	 <p>1221</p>
<p>0.33</p>	 <p>1222</p>

0.47	
	1223





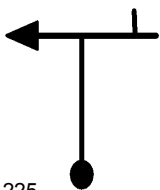

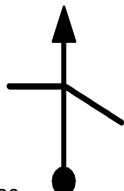
CUIDADO GERAL

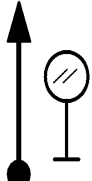
0.50	Neutro
N 4' 10.23.52	
	T279 1224

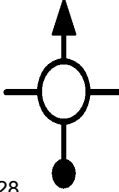
0.50	
V 42 10.27.52	
	T280 1225

0.98	
	1226

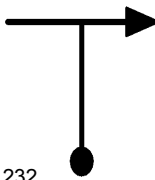
1.80	
	1227

<p>1.95</p>	 <p>1228</p>
<p>3.18</p>	 <p>1229</p>
<p>3.67</p> <p>V 45 10.32.24</p> <p>T281</p>	 <p>1230</p>
<p>3.69</p>	 <p>1231</p>
<p>3.95</p>	 <p>1232</p>
<p>3.98</p>	 <p>1233</p>

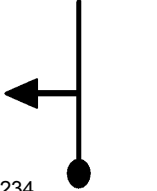
4.30	
V 30 10.33.15	
	T282 1234

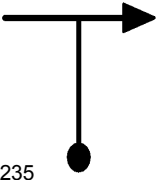
4.37	
V 45 10.33.24	
	T283 1235

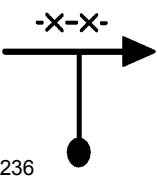
4.65	
V 30 10.33.46	
	T284 1236

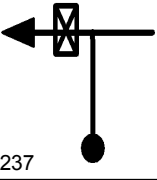
4.73	
	1237

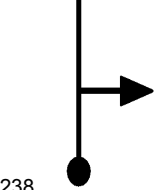
4.77	
V 24 10.34.00	
	T285 1238

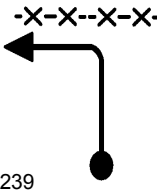
4.80	
	1239

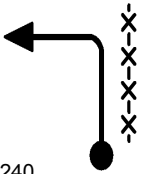
4.84	
	1240

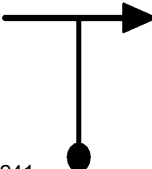
4.87	
V 45 10.34.16	
T286	1241

5.18	
	1242

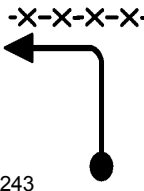
5.58	
V 33 10.35.13	
T287	1243

CUIDADO CERCA

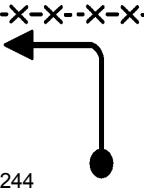
5.65	
	1244

<p>6.05</p> <p>V 45 10.36.03</p> <p>T288 1245</p>	
<p>6.30</p>	
<p>6.43</p>	<p>-x-x-x-x-</p>
<p>6.50</p> <p>V 51 10.36.40</p> <p>T289 1248</p>	
<p>6.90</p>	
<p>7.96</p> <p>N 4' 10.38.22</p> <p>T290 1250</p>	<p>Neutro</p>

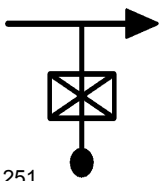
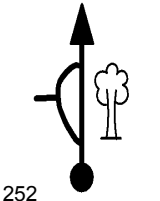
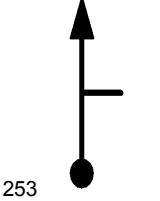
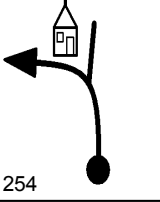
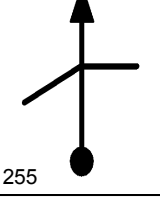
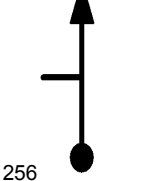
<p>7.96</p> <p>V 42 10.42.22</p> <p>T291</p>	 <p>1251</p>
<p>8.30</p>	 <p>1252</p>
<p>9.27</p>	 <p>1253</p>
<p>9.32</p>	 <p>1254</p>
<p>10.15</p>	 <p>1255</p>
<p>10.96</p>	 <p>1256</p>

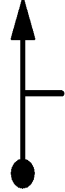
11.73	
	1257

ACELERAA

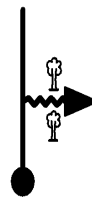
11.79	
V 51 10.47.51	
T292	1258

12.38	
	1259

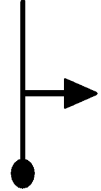

13.11	
0.00	
V 51 10.49.24	
T293	1260

0.37	
	1261

0.94	
	1262

CUIDADO ESTRADA GERAL

2.04	Neutro
N3'30s 10.51.49 T294	1263

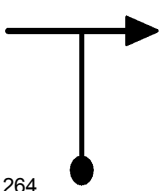
2.04	
V 42 10.55.19 T295	1264

2.15	
	1265

2.92	
	1266

TREVO

3.00	
	1267

CUIDADO!!

3.05	Neutro
N 1' 10.56.45	
T296	1268

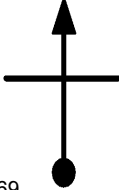
3.05	
V 42 10.57.45	
T297	1269

4.19	
	1270

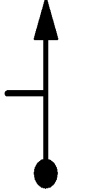
4.50	
	1271

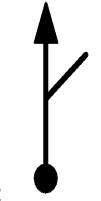
4.99	
	1272

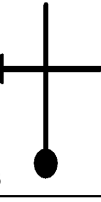
5.26	
V 39 11.00.55	
T298	1273

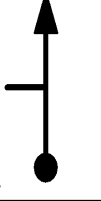
5.59	
	1274

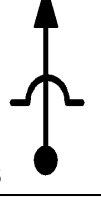
5.99	
	1275

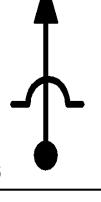
6.47	
	1276

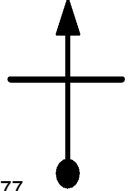
<p>7.02</p>	
	1277

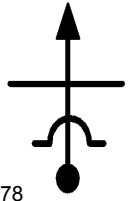
<p>7.33</p>	
	1278

CUIDADO AO ATRAVESSAR

<p>7.65</p>	<p>Neutro</p>
<p>N 1' 11.04.35</p>	
<p>T299</p>	1279

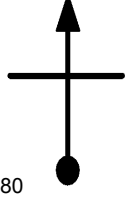
<p>7.65</p>	
<p>V 39 11.05.35</p>	
<p>T300</p>	1280

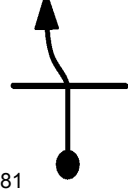
<p>8.29</p>	
	1281

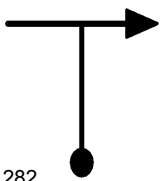
8.78	
	1282

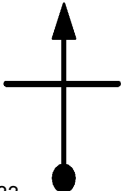
8.90	
	1283

PARE!!

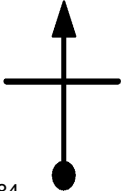
9.08	
	1284

PARE!!

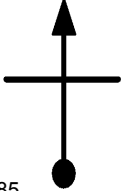
9.27	
	1285

PARE!!

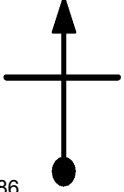
9.46	
	1286

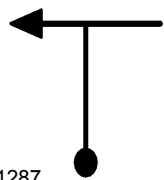
9.65	
	1287

9.72	
	1288

9.94	
	1289

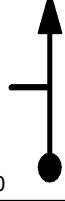
10.09	
	1290

10.24	
	1291

10.32	
	1292

10.76	
	1293

11.06	
	1294

FIM DE PROVA! ENTREGUE GPS

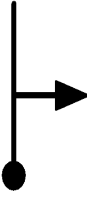
11.20	
N 0h 11.11.02	
T301	1295

FIM DE PROVA !!



www.t15.com.br

Tempo de Prova

Junior 11:11:02

