

INICIO

SENIOR

Vº ENDURO ENTRE A SERRA E O MAR
16 DE JULHO DE 2016



IMPORTANTE

**ENDURO ENTRE A SERRA
E O MAR 2016
GRAVATAL-SC
16 DE JULHO DE 2016**

**DIRETOR DE PROVA:
RICARDO DAUFEMBACK**

**SUPERVISOR:
JONAS SCHULZ**

**DISTANCIA:
65,83 KM**

**LARGADA:
COMUNIDADE DE SÃO
ROQUE**



**NEUTRO:
COMUNIDADE DE SÃO
ROQUE**

**CHEGADA:
COMUNIDADE DE SÃO
ROQUE**

**RESPEITE AS LEIS DE
TRANSITO E
PRINCIPALMENTE
OS TERRENOS E SEUS
RESPECTIVOS DONOS.**

**NA DUVIDA,
ACELERAAAAA...
...MAS DENTRO DE SEUS
LIMITES.**

BOM APETITE.

	CUIDADO
	ATENÇÃO
	MUITA ATENÇÃO



Tempo de Prova

SENIOR 03:00:27



AFERIÇÃO

NO POSTE

BAMP

0.00

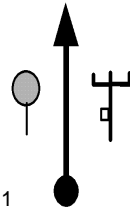

AFER 1

AFERIÇÃO

0.29



AFER 2

AFERIÇÃO

0.70



AFER 3

AFERIÇÃO

0.88



AFER 4

NO POSTE

BAMP

RETORNE

POR ONDE VEIO.

1.505

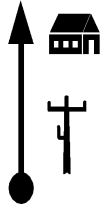

0.00

AFER 5



INICIO DE PROVA

INICIO DE PROVA

TRECHO COM

MOTO CONTRA

CUIDADO

0.00

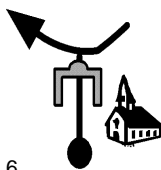

V 36 00.00.00

T1 6

0.28



V 36

T1 7

PELA PRINCIPAL

0.69



V 36

T1

8

1.27



V 36

T1

9

1.51



V 36

T1

10

2.17

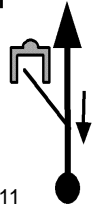

V 36

T1

11

2.20

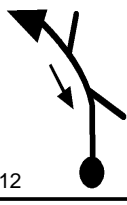

V 36

T1

12

2.38

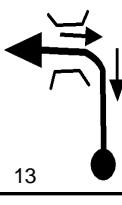

V 36

T1

13

FIM

MOTO

CONTRA

2.88









V 36

T1

14

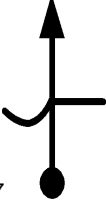
3.88		
V 36	T1	
4.29		
V 36	T1	
4.56		
V 36	T1	
E VAI COMECAR...		
LIMPANDO A VELA 1		
TRILHA DA ARGILA		
4.78		
V 40	00.07.58	
T2		18
4.89		
V 40	T2	
4.92		
V 40	T2	
5.16		
V 40	T2	

5.34	
V 42 00.08.48	
T3	22
5.92	
V 42	
T3	23
6.12	
V 42	
T3	24
7.02	
V 42	
T3	25
7.04	
V 42	
T3	26
7.09	
V 42	
T3	27
7.17	
V 37 00.11.25	
T4	28

7.40		
V 37		
T4		29
7.63		
0.00		
N 3'	00.12.10	
T5		30
0.00		
V 32	00.15.10	
T6		31
DESCIDA COM EROSÕES		
0.22		
V 32		
T6		32
0.44		
V 33	00.16.00	
T7		33
DESVIO		
BARREIRA		
1.21		
V 33		
T7		34

PEDRAS

1.56



V 33

T7

35

1.73



V 36

00.18.20

T8

36

1.74



V 36

T8

37

HARD 1

DESCENDO

1.87



V 33

00.18.34

T9

38

2.08

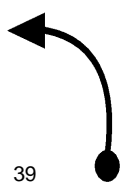

V 33

T9

39

2.26



V 33

T9

40

2.43



V 30

00.19.35

T10

41

PELA ESQUERDA

2.74



V 30

T10 42

ESCOLHA

3.37



V 25 00.21.28

T11 43

3.71



V 25

T11 44

NAO ERRE

3.78

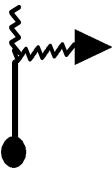

V 25

T11 45

3.82

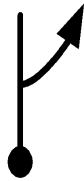

V 25

T11 46

4.04



V 25

T11 47

4.24



V 25

T11 48

4.40		
V 32	00.23.56	
T12		49
BAMP		
4.59		
V 32		
T12		50
4.63		
N3'30s	00.24.22	
T13		51
4.63		
V 25	00.27.52	
T14		52
4.67		
V 25		
T14		53
4.82		
V 37	00.28.20	
T15		54
5.00		
V 42	00.28.37	
T16		55

5.28		
V 42		
T16		

5.75		
V 42		
T16		

5.82		
0.00		
N 2'	00.29.47	
T17		58

0.00		
V 33	00.31.47	
T18		







ESTILO INDEPENDENCIA



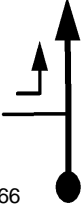
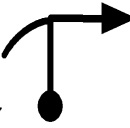

SUBINDO

SEGURAAAAAA

0.13		
V 40	00.32.02	
T19		

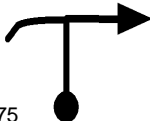
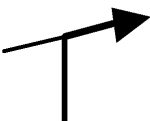



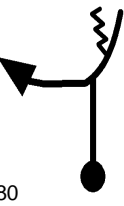

1.94	
V 40	
T19	61
2.10	
V 40	
T19	62
PELA ESQUERDA	
MATA-BURRO	
3.65	
V 40	
T19	63
3.83	
0.00	
N 5' 00.37.35	
T20	64
0.00	
V 36 00.42.35	
T21	65
0.17	
V 36	
T21	66
0.46	
V 36	
T21	67

0.83	
V 36	
	T21 68
0.84	
V 37	00.43.59
	T22 69
1.11	
V 37	
	T22 70
1.25	
V 37	
	T22 71
1.28	
V 34	00.44.41
	T23 72
CUIDADO DEGRAU	
1.44	
V 34	
	T23 73
1.48	
V 34	
	T23 74

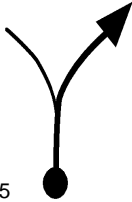

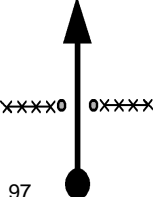



1.76		
V 34		
T23		75
2.13		
V 34		
T23		76
SITIO MEDICO		
2.22		
N 3'	00.46.21	
T24		77
DEVAGAR		
INICIO RADAR		
2.22		
V 24	00.49.21	
T25		78
FIM RADAR		
2.45		
V 30	00.49.55	
T26		79
TRILHA DA HELENA		
2.76		
V 40	00.50.33	
T27		80

3.44	
V 40	
T27	81
3.54	
V 44	00.51.43
T28	82
3.80	
V 44	
T28	83
CURVA PERIGOSA	
3.95	
V 44	
T28	84
ATENÇÃO NAO ERRE	
4.08	
V 34	00.52.27
T29	85
4.20	
V 40	00.52.40
T30	86
4.23	
V 40	
T30	87

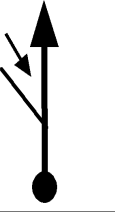
4.43		
V 44	00.53.00	
T31		88
CURVA PERIGOSA		
4.59		
V 44		
T31		89
4.71		
V 42	00.53.23	
T32		90
4.84		
V 42		
T32		91
4.92		
V 42		
T32		92
4.96		
V 42		
T32		93
5.05		
V 42		
T32		94

5.13		
V 33	00.53.59	
T33 95		
DESCE		
EROSOES		
5.74		
V 25	00.55.06	
T34 96		
5.89		
V 24	00.55.27	
T35 97		
5.94		
V 24		
T35 98		
6.10		
V 24		
T35 99		
BAMP		
6.15		
V 24		
T35 100		
6.16		
V 33	00.56.08	
T36 101		

6.22	
V 33	
	T36 102
6.34	
V 33	
	T36 103
CURRAL	
6.51	
V 33	
	T36 104
6.57	
0.00	
N3'30s 00.56.53	
	T37 105
TRILHA DO DIRCEU	
0.00	
V 38	01.00.23
	T38 106
0.21	
V 38	
	T38 107
0.22	
V 38	
	T38 108

0.40	
V 38	
T38	109
0.44	
V 38	
T38	110
0.68	
V 34	01.01.27
T39	111
CUIDADO	
SOBE	
0.80	
V 30	01.01.40
T40	112
0.91	
V 30	
T40	113
1.05	
V 33	01.02.10
T41	114
CUIDADO	
DESCE	
1.13	
V 33	
T41	115

1.36	
N 1' 01.02.44	
T42 116	
1.36	
V 40 01.03.44	
T43 117	
1.60	
V 42 01.04.05	
T44 118	
PEDRA	
2.47	
V 42	
T44 119	
2.68	
V 42	
T44 120	
2.77	
V 42	
T44 121	

3.05		
V 42	T44 122	
3.17		
V 38	01.06.20 T45 123	
3.28		
V 38	T45 124	
3.34		
V 38	T45 125	
3.38		
V 38	T45 126	
3.52		
V 38	T45 127	
SOBE		
3.67		
V 38	T45 128	

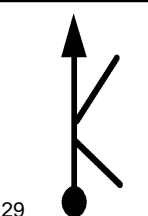
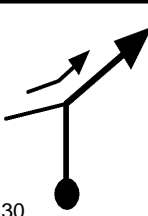
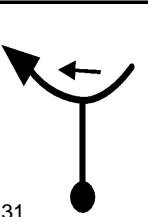
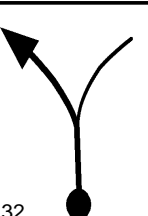
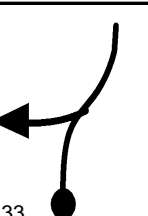
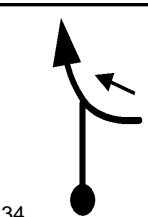
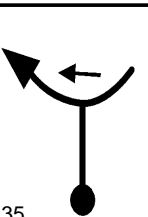
3.93	
V 38	
	T45 129
4.02	
V 38	
	T45 130
4.05	
V 38	
	T45 131
4.16	
V 38	
	T45 132
4.27	
V 38	
	T45 133
4.37	
V 38	
	T45 134
4.40	
V 38	
	T45 135

4.51		
V 38		
T45 136		
ESTRADA O		
INICIO MOTO CONTRA		
4.53		
V 38		
T45 137		
4.56		
N3'30s	01.08.31	
T46 138		
4.56		
V 36	01.12.01	
T47 139		
5.04		
V 36		
T47 140		
6.15		
V 36		
T47 141		
6.72		
V 36		
T47 142		

7.14		
V 36		
T47 143		
APOIO PRINCIPAL		
SÃO ROQUE		
7.41		
0.00		
N 18'	01.16.46	
T48 144		
0.00		
V 33	01.34.46	
T49 145		
0.28		
V 33		
T49 146		
0.69		
V 33		
T49 147		
1.27		
V 33		
T49 148		
1.51		
V 33		
T49 149		

2.17	
V 33	
T49	150
2.20	
V 33	
T49	151
2.38	
V 33	
T49	152
2.88	
V 36	01.40.01
T50	153
3.88	
V 36	
T50	154
4.29	
V 36	
T50	155
4.56	
V 36	
T50	156

LIMPANDO A VELA 2

4.78



V 43 | 01.43.11

T51 157

4.89



V 43

T51 158

4.92

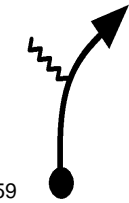

V 45 | 01.43.22

T52 159

5.16



V 45

T52 160

5.34

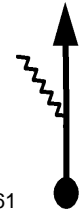

V 45

T52 161

5.92



V 45





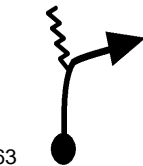

T52 162

6.12

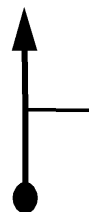

V 45

T52 163

7.02		
V 45	T52	
7.04		
V 45	T52	
7.09		
V 45	T52	
7.17		
V 36	01.46.22 T53	
7.40		
V 36	T53	
7.63		
0.00		
N 2'	01.47.08 T54	
0.00		
V 32	01.49.08 T55	

0.22		
V 32		
T55 171		

TRILHA DO VELHO DA CACHAÇA

0.44		
V 32		
T55 172		

1.26		
V 32		
T55 173		

1.72		
V 34	01.52.22	
T56 174		

DESCE PEDRAS

CUIDADOOOOOO...

2.34		
V 34		
☠☠☠	T56 175	

2.43		
V 34		
T56 176		

2.87		
V 34		
T56 177		

3.05		
V 34		
T56		178

RIO FUNDO

3.09		
N2'30s	01.54.47	
T57		179







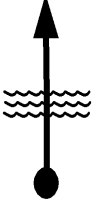

3.09		
V 40	01.57.17	
T58		180

3.23		
V 40		
T58		181

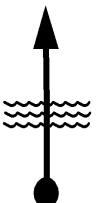
3.28		
V 40		
T58		182

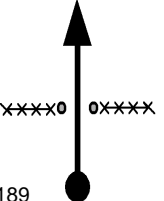
3.37		
V 40		
T58		183

3.50	
V 33 01.57.54	
T59	184
3.80	
V 33	
T59	185
3.92	
V 33	
T59	186
4.01	
V 33	
T59	187
4.19	
V 33	
T59	188
4.41	
V 33	
T59	189
HARD..	
4.54	
V 33	
T59	190

4.96	
0.00	
N 3' 02.00.33	
T60	191

TRILHA DA PEDREIRA

0.00	
V 40 02.03.33	
T61	192

CUIDADO

0.64	
V 40	
T61	193







1.41	
V 40	
T61	194

1.52	
N 1' 02.05.50	
T62	195

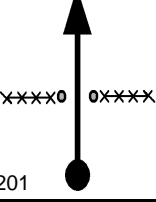

1.52	
V 36 02.06.50	
T63	196

TRECHO A SEGUIR
COM LAGE LISA
MUITO CUIDADO....





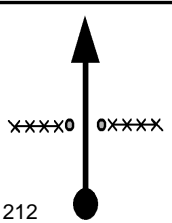
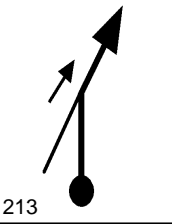
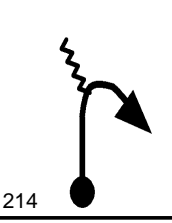
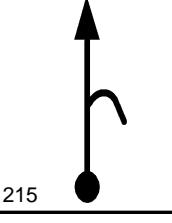
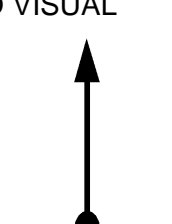

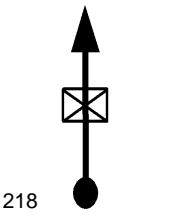
1.60	
V 36	
T63	197

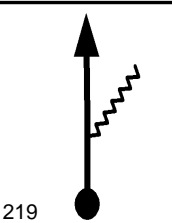
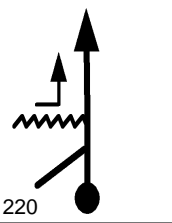
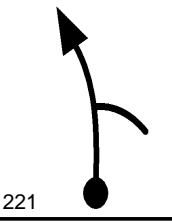
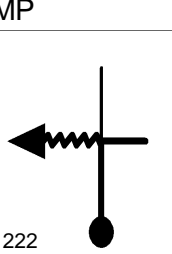
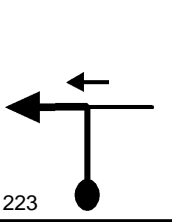
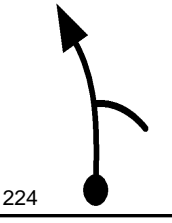
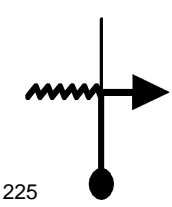
1.73		
V 36		
T63 198		
LISOOOO...		
LAGE DE PEDRA		
1.91		
V 25	02.07.29	
☠☠☠ T64 199		
SOBE		
1.94		
V 25		
T64 200		
2.28		
V 36	02.08.22	
T65 201		
2.42		
V 36		
T65 202		
2.50		
V 36		
T65 203		
2.63		
V 40	02.08.57	
T66 204		

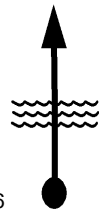
2.78	
V 40	
	T66 205
3.10	
V 40	
	T66 206
3.12	
V 40	
	T66 207
3.23	
V 39	02.09.51
	T67 208
CUIDADO	
BEMMM LISOOOO..	
3.50	
V 39	
	T67 209
LAGE DE PEDRA	
3.60	
V 25	02.10.25
	T68 210
LISO	
3.72	
V 25	
	T68 211

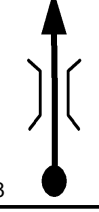
4.06	
V 39 02.11.32	
T69	212
4.21	
V 39	
T69	213
4.27	
V 39	
T69	214
4.42	
V 39	
T69	215
CURTA O VISUAL	
4.47	
0.00	
N 5' 02.12.09	
T70	216
0.00	
V 39 02.17.09	
T71	217
0.10	
V 39	
T71	218

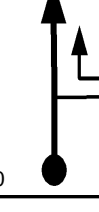
0.42	
V 39	
T71	219
0.44	
V 39	
T71	220
0.55	
V 39	
T71	221
BAMP	
0.64	
V 30	02.18.08
T72	222
0.82	
V 36	02.18.30
T73	223
0.94	
V 36	
T73	224
1.03	
V 36	
T73	225

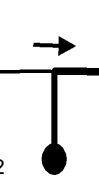
1.25	
V 36	
T73	226
1.30	
V 36	
T73	227
1.48	
V 36	
T73	228
1.61	
V 36	
T73	229
1.87	
V 38	02.20.15
T74	230
2.44	
V 38	
T74	231
3.05	
V 38	
T74	232

3.62	
V 38	
	T74 233
3.67	
0.00	
N 3' 02.23.06	
	T75 234
0.00	
V 42 02.26.06	
	T76 235
PRINCIPAL	
0.05	
V 42	
	T76 236
MORRO SECO	
2.00	
V 39 02.28.57	
	T77 237
2.48	
V 39	
	T77 238
3.03	
V 32 02.30.32	
	T78 239



3.12	
V 34	02.30.42
T79	240





3.39	
V 34	
T79	241

3.85	
V 25	02.32.00
T80	242

3.96	
V 25	02.32.15
T81	243

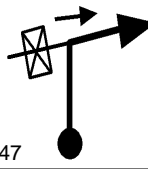
4.00	
V 25	
T81	244

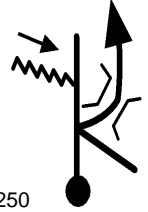
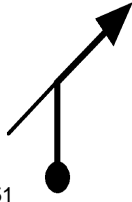
4.52	
V 32	02.33.36
T82	245

4.98		***** 
V 32		
	T82	246
5.01		
N 4'	02.34.31	
	T83	247
5.01		
V 39	02.38.31	
	T84	248
5.46		
V 39		
	T84	249
6.00		
V 37	02.40.02	
	T85	250
6.09		
V 37		
	T85	251
6.24		
V 37		
	T85	252

PICO DA TRILHA

VISUAL

ENTRE A SERRA E O MAR

6.48

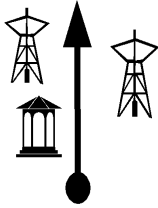

0.00

N 5' 02.40.49

T86 253

DESLOCAMENTO

0.00



D 2' 02.45.49

T87 254

DESCE FORTE

0.08



D 2'

T87 255

FIM DESLOCAMENTO

0.15

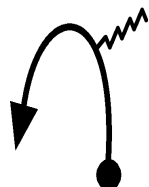

V 36 02.47.49

T88 256

0.30



V 36

T88 257

POR BAIXO DA PONTE



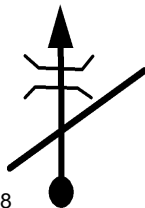



0.72







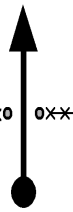

V 36

T88 258

0.76		
V 36	T88 259	
0.84		
V 36	T88 260	
1.08		
V 39	02.49.22 T89 261	
1.14		
V 39	T89 262	
1.34		
V 39	T89 263	
1.36		
V 42	02.49.48 T90 264	
1.52		
V 42	T90 265	

1.86	
V 34 02.50.31	
T91	266
1.97	
V 34	
T91	267
2.00	
V 34	
T91	268
2.03	
V 34	
T91	269
2.07	
V 34	
T91	270
2.16	
V 42 02.51.03	
T92	271
2.32	
V 42	
T92	272

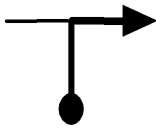

2.66	
V 42	
	T92 273
2.68	
N 1' 02.51.47	
	T93 274
2.68	
V 33 02.52.47	
	T94 275
2.77	
V 42 02.52.57	
	T95 276
3.12	
V 42	
	T95 277
4.03	
V 15 02.54.45	
	T96 278
4.28	
V 39 02.55.45	
	T97 279

4.33	
0.00	
N1'30s 02.55.50	
T98 280	

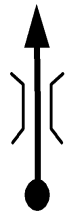
PELA PRINCIPAL	
0.00	
V 39 02.57.20	
T99 281	

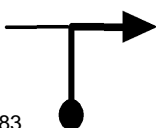
1.27	
V 39	
T99 282	

1.78	
V 39	
T99 283	

PARABENS..	
2.03	 
V 39 03.00.27	
T99 284	

FIM DE PROVA !!



www.t15.com.br

Tempo de Prova

SENIOR 03:00:27

FIM