

# INICIO

MÉDIA A

MÉDIA B

MÉDIA C

17 Enduro do RIO MAINA  
17/10/2020



## IMPORTANTE

PLANILHA TERMICA  
FITA ADESIVA DO LADO DE  
TRÁS. NÃO USE CANETA  
MARCA TEXTO,  
USE CANETA ESFEROGRÁFICA  
OU HIDROGRÁFICA

DIRETORES DE PROVA:  
SAMUEL RESENDE  
REALDO DA SILVA

REALIZAÇÃO:  
TRILHEIROS DO RIO

NOS TRECHOS URBANOS  
PREVALECEM AS LEIS DO  
CÓDIGO NACIONAL DE  
TRANSITO. É OBRIGAÇÃO  
RESPEITAR AS PROPRIEDADES  
ALHEIAS E OS MORADORES.  
A ORGANIZAÇÃO NÃO SE  
RESPONSABILIZA POR PASSAR  
PROGRAMAÇÃO DE NAVEGAÇÃO.  
É OBRIGAÇÃO DO PILOTO  
CONFERIR A PROGRAMAÇÃO DO  
NAVEGADOR.

LARGADA - 14:00 HS  
PARQUE DOS IMIGRANTES

NEUTRO PRINCIPAL  
PARTQUE DOS IMIGRANTES

CHEGADA NO MESMO  
LOCAL DA LARGADA

1 ETAPA KM  
2 ETAPA KM  
TOTAL KM 62,00

LEVANTAMENTO DA PROVA  
COM MOTO KTM 350 COM  
PNEU DIANTEIRO BOM  
E 12 LIBRAS

17/10/2020 Pág: 001

☠ CUIDADO  
☠☠ ATENÇÃO  
☠☠☠ MUITA ATENÇÃO

## Tempo de Prova

MÉDIA A 02:40:36

MÉDIA B 02:43:46

MÉDIA C 02:42:08



## AFERIÇÃO

0.00		1	AFER
0.18		2	AFER
0.66		3	AFER
1.10		4	AFER
1.32		5	AFER



## INÍCIO DE PROVA



17/10/2020 Pág: 002





0.00		6	V	42	00.00.00
				42	00.00.00
				42	00.00.00
			V		T1
0.05		7	V	42	
				42	
				42	
			V		T1
0.27		8	V	42	
				42	
				42	
			V		T1
0.42		9	V	42	
				42	
				42	
			V		T1
0.53		10	V	30	00.00.45
				24	00.00.45
				21	00.00.45
			V		T2
COSTEAR A CERCA					
0.60		11	V	30	
				24	
				21	
			V		T2
0.64		12	V	30	
				24	
				21	
			V		T2
0.66		13	V	30	
				24	
				21	
			V		T2
0.76		14	V	30	
				24	
				21	
			V		T2
0.84		15	V	30	
				24	
				21	
			V		T2

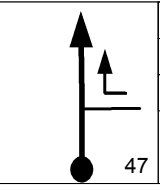
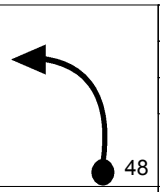
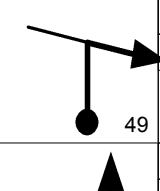
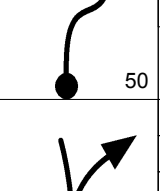
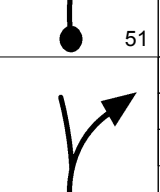
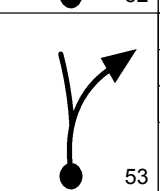
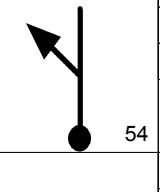
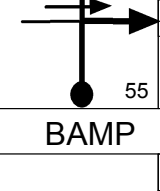

17/10/2020		Pág: 003	
<b>1.02</b>		30 24 21	V T2
<b>1.09</b>		30 24 21	V T2
<b>1.86</b>		30 24 21	V T2
<b>2.26</b>		30 24 21	V T2
<b>2.28</b>		30 24 21	V T2
<b>2.44</b>		30 24 21	V T2
<b>2.46</b>		2' 00.04.37 1' 30s 00.05.35 1' 00.06.16	N T3
<b>2.46</b>		42 00.06.37 42 00.07.05 42 00.07.16	V T4
<b>2.60</b>		42 42 42	V T4
<b>2.78</b>		42 42 42	V T4
<b>2.81</b>		42 42 42	V T4

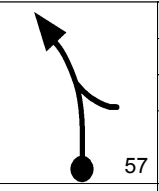
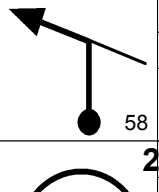

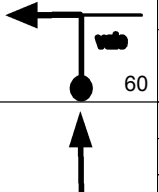
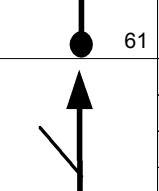
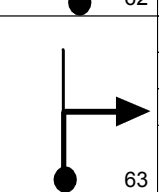
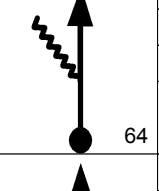
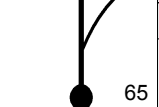
17/10/2020		Pág: 004	
<b>2.85</b>		36 00.07.10 33 00.07.38 30 00.07.50	V T5
<b>3.57</b>		42 00.08.22 42 00.08.57 42 00.09.16	V T6
<b>3.62</b>		42 42 42	V T6
<b>4.00</b>		42 42 42	V T6
<b>4.04</b>		45 00.09.03 42 00.09.37 39 00.09.56	V T7
<b>0.00</b>		45 42 39	V T7
<b>0.25</b>		45 42 39	V T7
<b>0.41</b>		45 42 39	V T7
<b>0.52</b>		45 42 39	V T7
<b>0.69</b>		1' 30s 00.09.58 1' 00.10.36 1' 00.11.00	N T8
<b>0.69</b>		42 00.11.28 42 00.11.36 42 00.12.00	V T9

17/10/2020		Pág: 005	
<b>0.91</b>		42 42 42	V T9
<b>1.01</b>		42 42 42	V T9
<b>1.24</b>		27 00.12.15 27 00.12.23 27 00.12.47	V T10
<b>1.84</b>		33 00.13.35 27 00.13.43 24 00.14.07	V T11
<b>1.89</b>		33 27 24	V T11
<b>2.04</b>		33 27 24	V T11
<b>2.31</b>		33 27 24	V T11
<b>2.43</b>		33 27 24	V T11
<b>2.44</b>		33 27 24	V T11
<b>2.48</b>		33 27 24	V T11

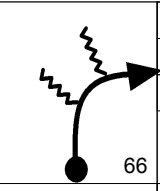
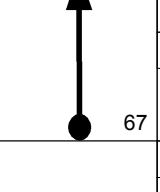
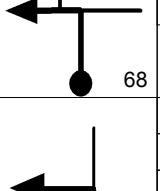
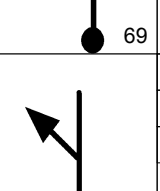
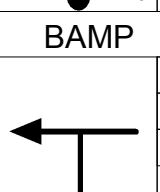
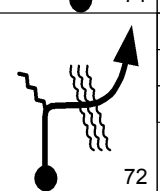
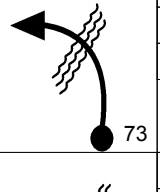
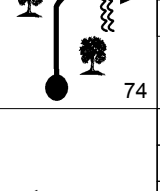
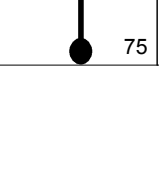
17/10/2020		Pág: 006	
<b>2.59</b>		33	
		27	
		24	
		V	T11
BAMP			
<b>2.77</b>		33	
		27	
		24	
		V	T11
<b>2.89</b>		33	
		27	
		24	
		V	T11
<b>3.09</b>		33	
		27	
		24	
		V	T11
<b>3.10</b>		33	
		27	
		24	
		V	T11
<b>3.17</b>		33	
		27	
		24	
		V	T11
<b>3.28</b>		33	
		27	
		24	
		V	T11
<b>3.30</b>		33	
		27	
		24	
		V	T11
<b>3.32</b>		33	
		27	
		24	
		V	T11
BAMP			
<b>3.52</b>		33	
		27	
		24	
		V	T11

17/10/2020		Pág: 007	
<b>3.61</b>		33	
		27	
		24	
		V	T11
<b>3.63</b>		33	
		27	
		24	
		V	T11
<b>3.75</b>		2'30s 00.17.03	
		2' 00.17.58	
		1' 00.18.54	
		N	T12
			
<b>3.75</b>		42 00.19.33	
		42 00.19.58	
		42 00.19.54	
		V	T13
<b>3.87</b>		42	
		42	
		42	
		V	T13
<b>4.12</b>		42	
		42	
		42	
		V	T13
<b>4.20</b>		36 00.20.12	
		30 00.20.37	
		27 00.20.32	
		V	T14
<b>4.26</b>		36 00.20.18	
		30 00.20.44	
		27 00.20.40	
		V	T15
<b>0.00</b>			
<b>0.07</b>		36	
		30	
		27	
		V	T15

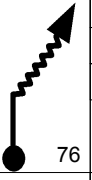
17/10/2020		Pág: 008	
<b>0.20</b>		36	
		30	
		27	
		V	T15
<b>0.30</b>		36	
		30	
		27	
		V	T15
<b>0.33</b>		36	
		30	
		27	
		V	T15
<b>0.38</b>		36	
		30	
		27	
		V	T15
<b>0.39</b>		36	
		30	
		27	
		V	T15
BAMP			
<b>0.57</b>		36	
		30	
		27	
		V	T15
<b>0.68</b>		36	
		30	
		27	
		V	T15
<b>0.73</b>		36	
		30	
		27	
		V	T15
<b>0.76</b>		36	
		30	
		27	
		V	T15
<b>0.79</b>		36	
		30	
		27	
		V	T15

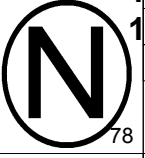
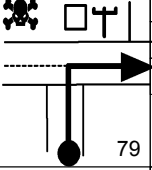
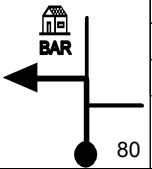
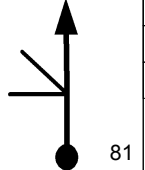
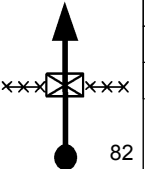
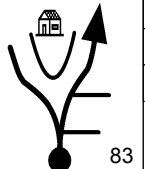
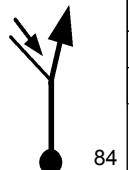
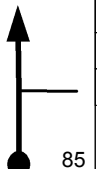
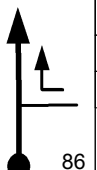
17/10/2020		Pág: 009	
0.88		36 30 27	V T15
0.93		36 30 27	V T15
0.99		1'30s 00.21.57 1'30s 00.22.43 1' 00.22.52	N T16
0.99		48 00.23.27 48 00.24.13 48 00.23.52	V T17
1.69		48 48 48	V T17
1.83		48 48 48	V T17
2.64		24 00.25.31 24 00.26.16 24 00.25.56	V T18
2.86		45 00.26.04 39 00.26.49 36 00.26.29	V T19
2.90		45 39 36	V T19
2.93		45 39 36	V T19
3.11		45 39 36	V T19

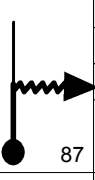
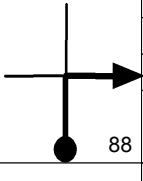
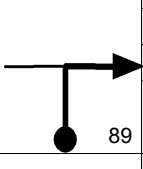
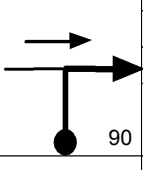
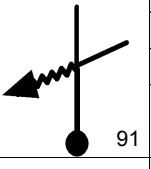
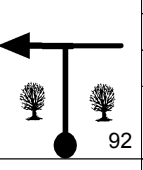
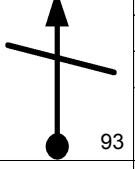
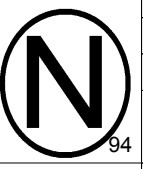
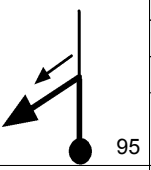
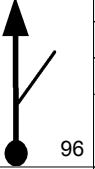
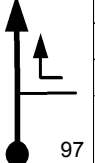
17/10/2020		Pág: 010	
3.15		45 39 36	V T19
3.28		45 39 36	V T19
3.34		45 39 36	V T19
3.43		39 00.26.49 33 00.27.42 27 00.27.26	V T20
3.52		39 33 27	V T20
3.57		42 00.27.02 33 00.27.57 30 00.27.45	V T21
3.73		42 33 30	V T21
3.86		1' 00.27.27 1' 00.28.29 1' 00.28.19	N T22
3.86		39 00.28.27 33 00.29.29 30 00.29.19	V T23
3.89		45 00.28.30 39 00.29.32 36 00.29.23	V T24
4.08		45 39 36	V T24

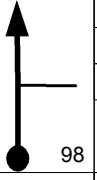
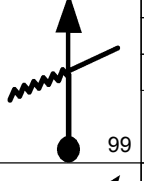
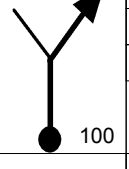
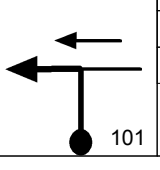
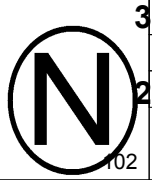
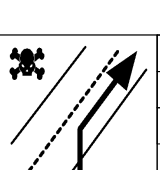
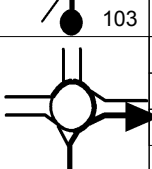
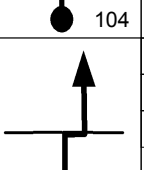
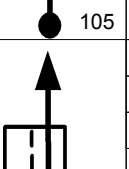
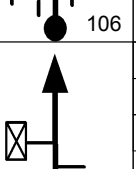
17/10/2020		Pág: 011	
4.12		45 39 36	V T24
4.18		45 39 36	V T24
4.75		45 39 36	V T24
4.88		45 39 36	V T24
5.27		3'30s 00.30.20 3' 00.31.40 2'30s 00.31.41	N T25
5.27		48 00.33.50 48 00.34.40 48 00.34.11	V T26
0.26		48 48 48	V T26
0.74		48 48 48	V T26
1.13		45 00.35.15 39 00.36.04 36 00.35.36	V T27
1.40		33 00.35.37 27 00.36.29 24 00.36.03	V T28

17/10/2020		Pág: 012	
<b>1.55</b>		33	
		27	
		24	
		V	T28
<b>2.22</b>		36	00.37.06
		33	00.38.19
		27	00.38.06
		V	T29
<b>2.29</b>		36	
		33	
		27	
		V	T29
<b>2.47</b>		36	
		33	
		27	
		V	T29
<b>2.61</b>		36	
		33	
		27	
		V	T29
<b>2.78</b>		36	
		33	
		27	
		V	T29
<b>2.90</b>		36	
		33	
		27	
		V	T29
<b>3.01</b>		39	00.38.25
		33	00.39.45
		30	00.39.51
		V	T30
<b>3.03</b>		39	
		33	
		30	
		V	T30
<b>3.15</b>		39	
		33	
		30	
		V	T30
<b>3.19</b>		39	
		33	
		30	
		V	T30

17/10/2020		Pág: 013	
<b>3.24</b>		39	
		33	
		30	
		V	T30
<b>3.39</b>		39	
		33	
		30	
		V	T30
<b>3.46</b>		39	
		33	
		30	
		V	T30
<b>3.55</b>		39	
		33	
		30	
		V	T30
<b>3.70</b>		39	
		33	
		30	
		V	T30
<b>3.80</b>		39	
		33	
		30	
		V	T30
<b>3.97</b>		39	
		33	
		30	
		V	T30
<b>4.04</b>		39	
		33	
		30	
		V	T30
<b>4.27</b>		39	
		33	
		30	
		V	T30

17/10/2020		Pág: 014	
<b>4.32</b>		39	
		33	
		30	
		V	T30
<b>4.50</b>		39	
		33	
		30	
		V	T30
<b>4.69</b>		39	
		33	
		30	
		V	T30
<b>4.74</b>		39	
		33	
		30	
		V	T30
<b>4.84</b>		39	
		33	
		30	
		V	T30
<b>4.88</b>		39	
		33	
		30	
		V	T30
<b>4.93</b>		39	
		33	
		30	
		V	T30
<b>5.67</b>		39	
		33	
		30	
		V	T30
<b>6.10</b>		39	
		33	
		30	
		V	T30
<b>6.14</b>		39	
		33	
		30	
		V	T30
<b>6.54</b>		4'	00.43.51
		3'	00.46.10
		2'	00.46.55
		N	T31

17/10/2020		Pág: 015	
<b>6.54</b> <b>0.00</b>		48 48 48	00.47.51 00.49.10 00.48.55
	139	V	T32
<b>0.26</b>		48 48 48	
	140	V	T32
<b>1.00</b>		42 42 42	00.49.06 00.50.25 00.50.10
	141	V	T33
<b>1.40</b>		42 42 42	
	142	V	T33
<b>1.64</b>		42 42 42	
	143	V	T33
<b>1.76</b>		42 42 42	
	144	V	T33
<b>1.97</b>		39 33 27	00.50.29 00.51.48 00.51.33
	145	V	T34
<b>2.06</b>		39 33 27	
	146	V	T34
<b>2.18</b>		39 33 27	
	147	V	T34
<b>2.21</b>		39 33 27	
	148	V	T34
<b>2.26</b>		39 33 27	
	149	V	T34

17/10/2020		Pág: 016	
<b>2.30</b>		39 33 27	
	150	V	T34
<b>2.37</b>		39 33 27	
	151	V	T34
<b>2.50</b>		39 33 27	
	152	V	T34
<b>2.56</b>		39 33 27	
	153	V	T34
<b>2.58</b>		39 33 27	
	154	V	T34
<b>2.66</b>		39 33 27	
	155	V	T34
<b>2.78</b>		39 33 27	
	156	V	T34
<b>2.88</b>		39 33 27	
	157	V	T34
<b>3.02</b>		39 33 27	
	158	V	T34
<b>3.04</b>		39 33 27	
	159	V	T34
<b>3.19</b>		39 33 27	
	160	V	T34

17/10/2020		Pág: 017	
<b>3.39</b>		39 33 27	
	161	V	T34
<b>3.59</b>		39 33 27	
	162	V	T34
<b>3.69</b>		39 33 27	
	163	V	T34
<b>3.74</b>		39 33 27	
	164	V	T34
<b>3.79</b>		39 33 27	
	165	V	T34
<b>3.93</b>		39 33 27	
	166	V	T34
<b>4.01</b>		39 33 27	
	167	V	T34
<b>4.04</b>		39 33 27	
	168	V	T34
<b>4.06</b>		39 33 27	
	169	V	T34
<b>4.21</b>		4' 3'30s 2'30s	00.53.56 00.55.52 00.56.32
	170	N	T35
<b>4.21</b>		24 24 24	00.57.56 00.59.22 00.59.02
	171	V	T36



17/10/2020		Pág: 018	
<b>4.66</b>		36	00.59.03
		36	01.00.30
		36	01.00.09
		V	<b>T37</b>
<b>5.30</b>		36	
		36	
		36	
		V	T37
<b>5.79</b>		42	01.00.56
		42	01.02.23
		42	01.02.02
		V	<b>T38</b>
<b>6.15</b>		42	
		42	
		42	
		V	T38
<b>6.79</b>		42	
		42	
		42	
		V	T38
<b>7.01</b>		21	01.02.41
		21	01.04.07
		21	01.03.47
		V	<b>T39</b>
<b>7.26</b>		36	01.03.24
		30	01.04.50
		27	01.04.29
		V	<b>T40</b>
<b>7.45</b>		36	
		30	
		27	
		V	T40
<b>7.50</b>		42	01.03.48
		42	01.05.19
		42	01.05.01
		V	<b>T41</b>

17/10/2020		Pág: 019	
DESLOCAMENTO			
<b>8.05</b>		8'	01.04.35
		8'	01.06.06
		8'	01.05.49
		D	<b>T42</b>
<b>8.34</b>			
		D	T42
<b>8.93</b>			
		D	T42
<b>9.05</b>			
		D	T42
<b>9.51</b>			
		D	T42
FIM DESLOCAMENTO			
<b>9.71</b>			
		D	T42
NEUTRO			
PRINCIPAL			
<b>9.71</b>		15'	01.12.35
		15'	01.14.06
		15'	01.13.49
<b>0.00</b>		N	<b>T43</b>
INICIO			
SEGUNDA ETAPA			
<b>0.00</b>		36	01.27.35
		30	01.29.06
		27	01.28.49
		V	<b>T44</b>
<b>0.03</b>		36	
		30	
		27	
		V	T44

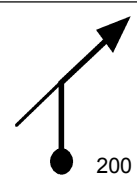
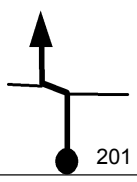
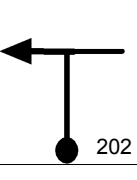
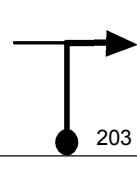
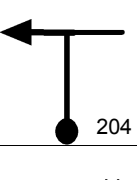
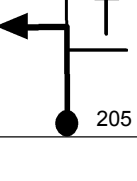
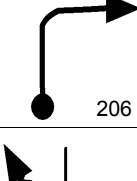
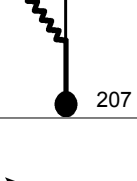
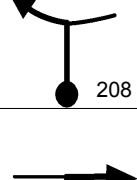
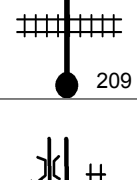
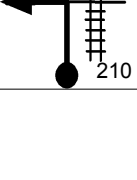

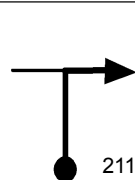
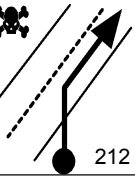
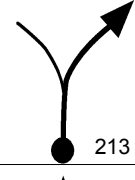
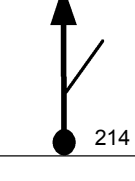
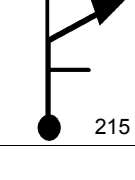
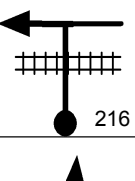
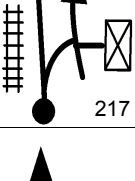
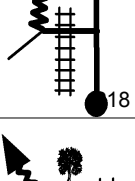
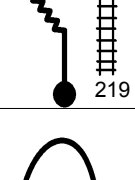
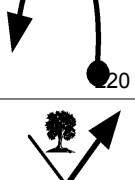
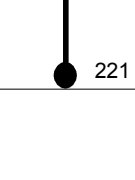

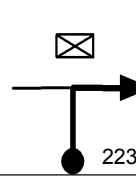
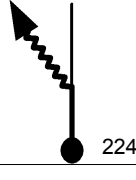
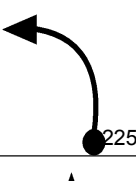
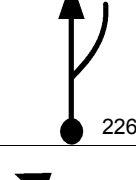
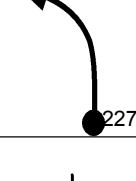
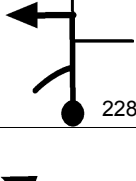
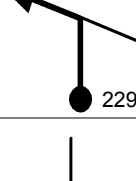
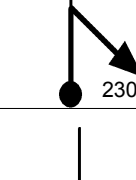

17/10/2020		Pág: 020	
<b>0.30</b>		36	
		30	
		27	
		V	T44
<b>1.02</b>		36	
		30	
		27	
		V	T44
<b>1.47</b>		36	
		30	
		27	
		V	T44
<b>1.70</b>		36	
		30	
		27	
		V	T44
<b>2.02</b>		36	
		30	
		27	
		V	T44
<b>2.13</b>		45	01.31.08
		45	01.33.22
		45	01.33.33
		V	<b>T45</b>
<b>2.40</b>		45	
		45	
		45	
		V	T45
<b>2.85</b>		45	
		45	
		45	
		V	T45
<b>3.03</b>		27	01.32.20
		24	01.34.34
		21	01.34.45
		V	<b>T46</b>
BAMP			
<b>3.24</b>		27	
		24	
		21	
		V	T46



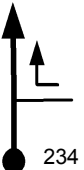
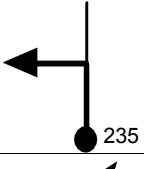

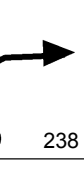

17/10/2020		Pág: 021	
<b>3.35</b>		27 24 21	V T46
<b>3.41</b>		39 01.33.11 39 01.35.31 39 01.35.50	V T47
<b>3.56</b>		39 39 39	V T47
<b>3.59</b>		39 39 39	V T47
<b>3.75</b>		39 39 39	V T47
<b>4.12</b>		39 39 39	V T47
<b>4.27</b>		39 39 39	V T47
<b>4.43</b>		30 01.34.45 27 01.37.05 24 01.37.24	V T48
<b>4.45</b>		30 27 24	V T48
<b>4.49</b>		30 27 24	V T48
<b>4.63</b>		30 27 24	V T48

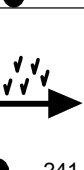

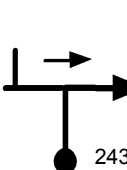

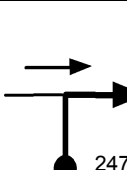
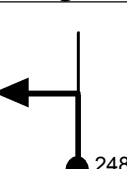

17/10/2020		Pág: 022	
<b>4.96</b>		42 01.35.48 42 01.38.16 42 01.38.43	V T49
<b>5.04</b> <b>0.00</b>		42 01.35.55 42 01.38.22 42 01.38.50	V T50
<b>0.13</b>		42 42 42	V T50
<b>0.29</b>		42 42 42	V T50
<b>0.71</b>		42 42 42	V T50
<b>0.81</b>		36 01.37.05 30 01.39.32 27 01.40.00	V T51
<b>0.97</b>		36 30 27	V T51
<b>1.22</b>		36 30 27	V T51
<b>1.31</b>		30 01.37.55 24 01.40.32 21 01.41.06	V T52
<b>1.59</b>		30 24 21	V T52
<b>1.62</b>		30 24 21	V T52

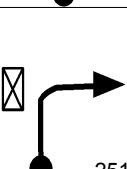
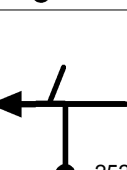
17/10/2020		Pág: 023	
<b>1.69</b>		2'30s 01.38.40 1'30s 01.41.29 1' 01.42.11	N T53
<b>1.69</b>		42 01.41.10 36 01.42.59 33 01.43.11	V T54
<b>2.08</b>		42 36 33	V T54
<b>2.50</b>		42 36 33	V T54
<b>3.16</b>		42 36 33	V T54
<b>3.30</b>		42 36 33	V T54
<b>3.55</b>		42 36 33	V T54
<b>3.84</b>		42 36 33	V T54
<b>3.89</b>		42 36 33	V T54
<b>4.01</b>		30 01.44.29 24 01.46.51 21 01.47.25	V T55
<b>4.32</b>		2'30s 01.45.06 2' 01.47.37 1' 01.48.18	N T56

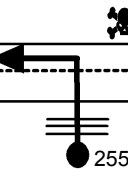

17/10/2020		Pág: 024	
<b>4.32</b>		30	01.47.36
		24	01.49.37
		21	01.49.18
		V	T57
<b>4.37</b> <b>0.00</b>		42	01.47.42
		36	01.49.45
		33	01.49.26
		V	T58
<b>0.21</b>		42	
		36	
		33	
		V	T58
<b>0.30</b>		42	
		36	
		33	
		V	T58
<b>0.32</b>		42	
		36	
		33	
		V	T58
<b>0.60</b>		42	
		36	
		33	
		V	T58
<b>0.74</b>		42	
		36	
		33	
		V	T58
			
<b>1.06</b>		42	
		36	
		33	
		V	T58
<b>1.23</b>		42	
		36	
		33	
		V	T58

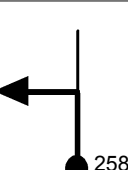
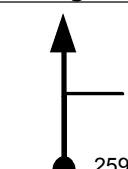
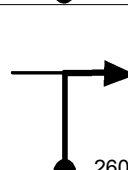
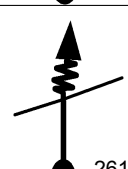
17/10/2020		Pág: 025	
<b>1.26</b>		42	
		36	
		33	
		V	T58
<b>1.40</b>		42	
		36	
		33	
		V	T58
<b>1.54</b>		42	
		36	
		33	
		V	T58
<b>1.65</b>		42	
		36	
		33	
		V	T58
<b>1.70</b>		42	
		36	
		33	
		V	T58
<b>1.73</b>		42	
		36	
		33	
		V	T58
<b>1.94</b>		42	
		36	
		33	
		V	T58
<b>2.03</b>		42	
		36	
		33	
		V	T58
<b>2.10</b>		42	
		36	
		33	
		V	T58
<b>2.33</b>		42	
		36	
		33	
		V	T58
<b>2.47</b>		42	
		36	
		33	
		V	T58

17/10/2020		Pág: 026	
<b>2.82</b>		3'30s	01.51.44
		3'	01.54.27
		2'	01.54.34
		N	T59
<b>2.82</b>		24	01.55.14
		24	01.57.27
		24	01.56.34
		V	T60
			
<b>3.16</b>		45	01.56.05
		45	01.58.18
		45	01.57.25
		V	T61
<b>3.96</b>		45	
		45	
		45	
		V	T61
<b>3.97</b>		33	01.57.10
		27	01.59.23
		24	01.58.30
		V	T62
<b>4.15</b>		33	
		27	
		24	
		V	T62
<b>4.18</b>		33	
		27	
		24	
		V	T62
<b>4.22</b>		33	
		27	
		24	
		V	T62
<b>4.40</b>		33	
		27	
		24	
		V	T62
<b>4.57</b>		33	
		27	
		24	
		V	T62

17/10/2020		Pág: 027	
<b>4.97</b>		33 27 24	V T62
<b>4.99</b>		33 27 24	V T62
<b>5.02</b>		33 27 24	V T62
<b>5.41</b>		33 27 24	V T62
ACELERA			
<b>5.50</b>		1'30s 01.59.57 1' 02.02.47 30s 02.02.19	N T63
ACELERA			
<b>5.50</b>		30 02.01.27 24 02.03.47 21 02.02.49	V T64
<b>5.53</b>		30 24 21	V T64
<b>5.58</b>		30 24 21	V T64
<b>5.61</b>		30 24 21	V T64
<b>5.65</b> <b>0.00</b>		24 02.01.45 21 02.04.09 18 02.03.15	V T65

17/10/2020		Pág: 028	
<b>0.07</b>		24 21 18	V T65
<b>0.11</b>		36 02.02.01 33 02.04.28 30 02.03.37	V T66
<b>0.50</b>		36 33 30	V T66
<b>0.88</b>		36 33 30	V T66
<b>1.08</b>		36 33 30	V T66
<b>1.21</b>		39 02.03.51 33 02.06.28 30 02.05.49	V T67
☠☠☠			
<b>1.51</b>		2' 02.04.19 1'30s 02.07.01 1' 02.06.25	N T68
☠☠☠			
<b>1.51</b>		42 02.06.19 42 02.08.31 42 02.07.25	V T69
<b>2.10</b>		42 42 42	V T69
<b>2.77</b>		42 42 42	V T69

17/10/2020		Pág: 029	
<b>2.95</b>		36 02.08.22 30 02.10.34 27 02.09.28	V T70
<b>3.17</b>		36 30 27	V T70
<b>3.20</b>		36 30 27	V T70
<b>3.26</b>		36 30 27	V T70
<b>3.54</b>		36 30 27	V T70
<b>3.60</b>		36 30 27	V T70
<b>3.65</b>		36 30 27	V T70
<b>3.71</b>		36 30 27	V T70
<b>3.75</b>		36 30 27	V T70
<b>3.80</b>		36 30 27	V T70
<b>3.98</b>		36 30 27	V T70







<b>4.04</b>		36	V	T70
		30		
		27		
		294		
<b>4.11</b>		36	V	T70
		30		
		27		
		295		
<b>4.15</b>		36	V	T70
		30		
		27		
		296		
<b>4.39</b>		36	V	T70
		30		
		27		
		297		
<b>4.48</b>		33 02.10.55	V	T71
		27 02.13.38		
		24 02.12.52		
		298		
<b>4.52</b>		33	V	T71
		27		
		24		
		299		



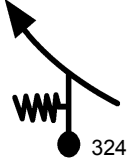
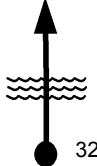



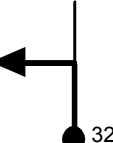

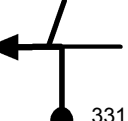
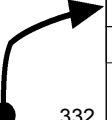
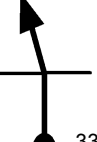



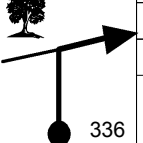
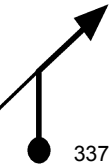

<b>4.55</b>		33	V	T71
		27		
		24		
		300		
<b>4.61</b>		33	V	T71
		27		
		24		
		301		
<b>4.69</b>		33	V	T71
		27		
		24		
		302		

<b>4.73</b>		33	V	T71
		27		
		24		
		303		
<b>4.82</b>		33	V	T71
		27		
		24		
		304		
<b>4.91</b>		2'30s 02.11.42	N	T72
		2' 02.14.35		
		1'30s 02.13.57		
		305		
<b>4.91</b>		36 02.14.12	V	T73
		30 02.16.35		
		27 02.15.27		
		306		
<b>5.12</b>		36	V	T73
		30		
		27		
		307		
<b>5.38</b>		36	V	T73
		30		
		27		
		308		
<b>5.52</b>		36	V	T73
		30		
		27		
		309		
<b>5.72</b>		36	V	T73
		30		
		27		
		310		
<b>6.02</b>		1'30s 02.16.03	N	T74
		1' 02.18.48		
		1' 02.17.55		
		311		
<b>6.02</b>		39 02.17.33	V	T75
		33 02.19.48		
		30 02.18.55		
		312		
<b>0.00</b>		39	V	T75
		33		
		30		
		313		

<b>0.38</b>		39	V	T75
		33		
		30		
		314		
<b>0.49</b>		39	V	T75
		33		
		30		
		315		
<b>0.62</b>		24 02.18.30	V	T76
		21 02.20.56		
		18 02.20.09		
		316		
<b>0.65</b>		24	V	T76
		21		
		18		
		317		
<b>1.01</b>		33 02.19.29	V	T77
		27 02.22.03		
		24 02.21.27		
		318		
<b>1.27</b>		33 02.19.57	V	T78
		33 02.22.37		
		33 02.22.06		
		319		
<b>1.45</b>		33	V	T78
		33		
		33		
		320		
<b>1.60</b>		2' 02.20.33	N	T79
		2' 02.23.13		
		1'30s 02.22.42		
		321		
<b>1.60</b>		39 02.22.33	V	T80
		39 02.25.13		
		39 02.24.12		
		322		
<b>1.69</b>		39 02.22.42	V	T81
		30 02.25.22		
		27 02.24.21		
		323		

17/10/2020		Pág: 033	
<b>1.73</b>		39 30 27	V T81
<b>1.78</b>		39 30 27	V T81
<b>1.82</b>		39 30 27	V T81
<b>1.84</b>		39 30 27	V T81
<b>1.95</b>		39 30 27	V T81
<b>2.03</b>		39 30 27	V T81
<b>2.14</b>		39 30 27	V T81
<b>2.17</b>		39 30 27	V T81
<b>2.30</b>		39 30 27	V T81
<b>2.56</b>		39 30 27	V T81
BAMP			

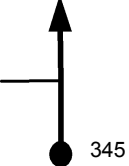
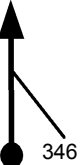
17/10/2020		Pág: 034	
<b>2.59</b>		39 30 27	V T81
<b>2.62</b>		39 30 27	V T81
BAMP			
<b>2.66</b>		39 30 27	V T81
<b>2.70</b>		39 30 27	V T81
<b>2.74</b>		39 30 27	V T81
<b>2.79</b>		39 30 27	V T81
<b>2.83</b>		39 30 27	V T81
<b>2.98</b>		39 30 27	V T81
<b>3.02</b>		39 30 27	V T81
<b>3.13</b>		2' 02.24.54 2' 02.28.15 1'30s 02.27.33	N T82

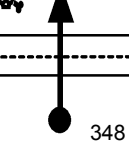
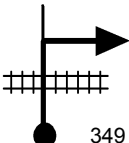
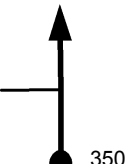
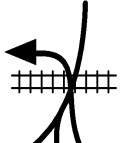
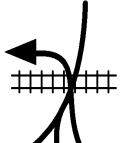
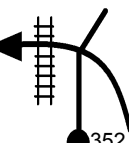
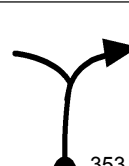
17/10/2020		Pág: 035	
<b>3.13</b>		42 42 42	02.26.54 02.30.15 02.29.03 V T83
<b>3.46</b>		42 42 42	V T83
<b>3.97</b>		42 42 42	V T83
☠☠☠			
<b>4.15</b>		1'30s 02.28.22 1'30s 02.31.42 1' 02.30.30	N T84
☠☠☠			
<b>4.15</b>		45 45 45	02.29.52 02.33.12 02.31.30 V T85
<b>4.70</b>		45 45 45	V T85
<b>5.04</b>		45 45 45	V T85
<b>5.83</b>		36 30 27	02.32.06 02.35.26 02.33.44 V T86
<b>0.00</b>		V	T86
<b>0.74</b>		42 42 42	02.33.20 02.36.55 02.35.23 V T87
<b>0.76</b>		42 42	V T87

17/10/2020		Pág: 036	
<b>0.79</b>		42	
		42	
		42	
		V	T87
☠☠☠			
<b>0.96</b>		42	
		42	
		42	
		V	T87
☠☠☠			
<b>1.12</b>		36	02.33.53
		30	02.37.28
		27	02.35.56
		V	T88
<b>1.31</b>		36	
		30	
		27	
		V	T88
SOBE			
<b>1.72</b>		36	
		30	
		27	
		V	T88
<b>2.74</b>		36	
		30	
		27	
		V	T88
☠☠			
<b>2.89</b>		3'	02.36.50
		2'	02.41.00
		1'30s	02.39.52
		N	T89
☠☠			
<b>2.89</b>		42	02.39.50
		42	02.43.00
		42	02.41.22
		V	T90

17/10/2020		Pág: 037	
<b>3.14</b>		42	
		42	
		42	
		V	T90
<b>3.36</b>		42	
		42	
		42	
		V	T90
<b>3.43</b>		42	02.40.36
		42	02.43.46
		42	02.42.08
		V	T90
<b>FIM DE PROVA !!</b>			
<a href="http://www.t15.com.br">www.t15.com.br</a>			
O motoclub TRILHEIROS DO RIO gostaria de agradecer todos os patrocinadores, donos de terrenos e amigos que participaram direta ou indiretamente para o acontecimento deste evento.			
<b>Tempo de Prova</b>			
MÉDIA A 02:40:36			
MÉDIA B 02:43:46			
MÉDIA C 02:42:08			
<b>FIM</b>			