

INICIO

MÉDIA C

I ENDURO LAMA NA VEIA
28 DE ABRIL DE 2018



IMPORTANTE

PLANILHA TERMICA
FITA ADESIVA DO LADO DE
TRÁS. NÃO USE CANETA
MARCA TEXTO,
USE CANETA ESFEROGRÁFICA
OU HIDROGRÁFICA

DIRETORES DE PROVA:
DOUGLAS ZANELATO
PAULO BIROLO



REALIZAÇÃO:
EQUIPE LAMA NA VEIA

NOS TRECHOS URBANOS
PREVALECEM AS LEIS DO
CÓDIGO NACIONAL DE
TRANSITO. É OBRIGAÇÃO
RESPEITAR AS PROPRIEDADES
ALHEIAS E OS MORADORES.
A ORGANIZAÇÃO NÃO SE
RESPONSABILIZA POR PASSAR
PROGRAMAÇÃO DE NAVEGAÇÃO.
É OBRIGAÇÃO DO PILOTO
CONFERIR A PROGRAMAÇÃO DO
NAVEGADOR.

LARGADA - 14:00 HS
PARQUE MUNICIPAL DE URUSSANGA
NEUTRO PRINCIPAL
LOCALIDADE DE RIO AMÉRICA
CHEGADA NO MESMO
LOCAL DA LARGADA

1 ETAPA KM 30,64
2 ETAPA KM 35,11
TOTAL KM 65,75

LEVANTAMENTO DA PROVA
COM MOTO WR 250F COM
PNEU DIANTEIRO BOM
E 11 LIBRAS

 CUIDADO
 ATENÇÃO
 MUITA ATENÇÃO

Tempo de Prova

MÉDIA C 03:09:03



AFERIÇÃO





W= 1172

AFERIÇÃO NO BAIRRO

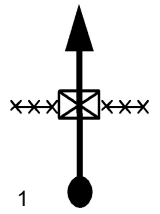
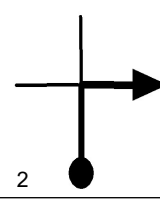
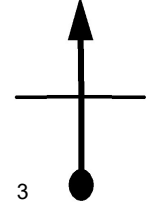
DEVAGAR

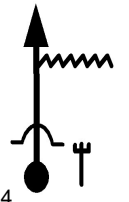
RESPEITEM OS MORADORES

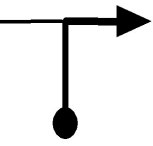
0.00	
AFER	1
0.11	
AFER	2
0.18	
AFER	3

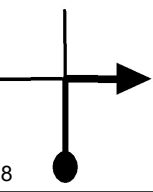
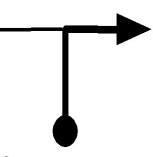
0.26	
AFER	4
0.36	
AFER	5
0.44	
 AFER	6
0.59	
AFER	7
0.66	
AFER	8
0.86	
AFER	9

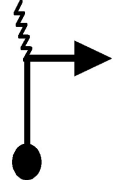
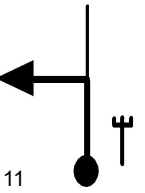
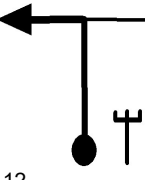
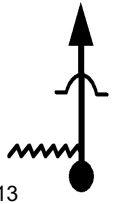
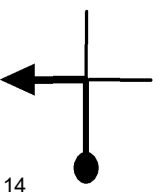
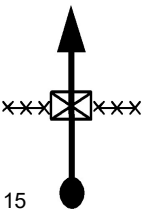
0.93	
AFER	10
1.04	
AFER	11
1.18	
AFER	12
1.30	
AFER	13
DEVAGAR	
PROXIMO AO HOSPITAL	
1.44	
AFER	14
AFERIÇÃO	
1,568	
1.56	
AFER	15



INICIO DE PROVA

INICIO PROVA

0.00

V 24 00.00.00

T1

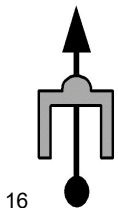

16

0.04

V 24

T1

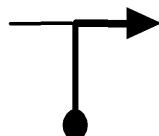

17

0.13

V 24

T1

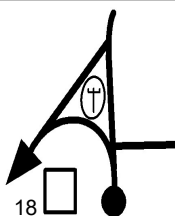

18

0.18

V 27 00.00.27

T2

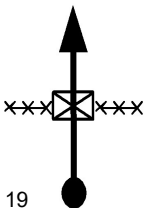

19

0.29

V 27

T2

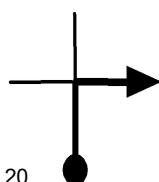

20

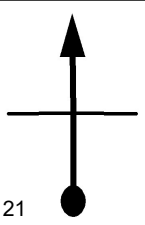
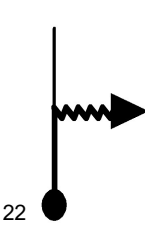
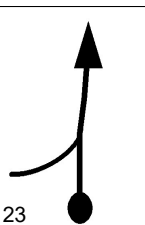
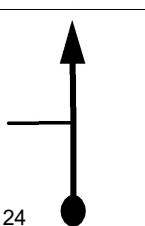
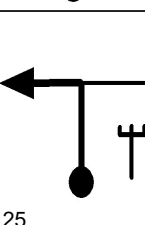
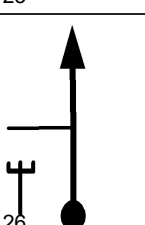
0.37	
V 27	
T2	21
SUBIDA	
COM EROSÕES	
0.45	
V 18 00.01.03	
T3	22
0.59	
V 24 00.01.31	
T4	23
0.78	
V 24	
T4	24
0.85	
V 24	
T4	25
1.07	
V 24	
T4	26

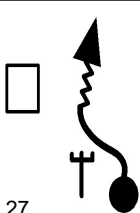
1.25	
V 12 00.03.10	
T5	27

BAMBUZAL

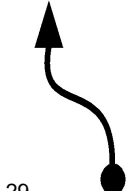

1.28	
V 30 00.03.19	
T6	28

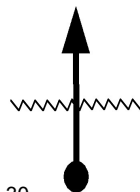
1.52	
V 30	
T6	29

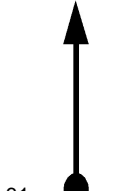
1.58	
V 30	
T6	30

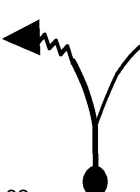
1.82	
V 30	
T6	31

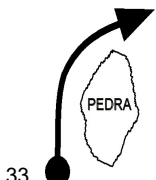
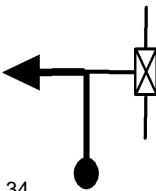
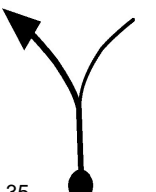
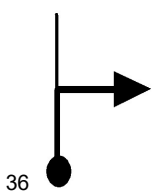
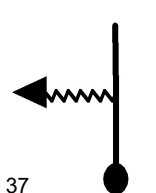
1.85	
V 30	
T6	32

2.01	
V 30	33
2.10	
V 21 00.04.57	34
2.24	
V 21	35
2.33	
V 21	36
2.35	
V 21	37
2.43	
0.00	
NI'30s 00.05.54	38
	T8

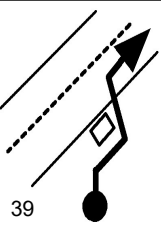
0.00	
V 42 00.07.24	
T9	39

CUIDADO

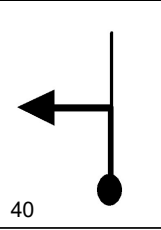
0.26	
V 36 00.07.46	
T10	40

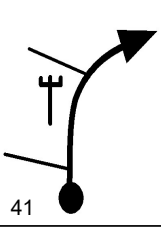
0.68	
V 36	
T10	41

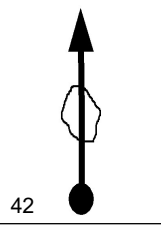
1.22	
V 36	
T10	42

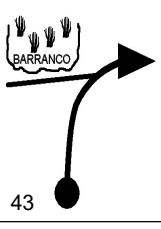
1.41	
V 36	
T10	43

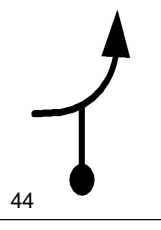
1.48	
V 27 00.09.48	
T11	44

CUIDADO

ESTRADA GERAL

1.58

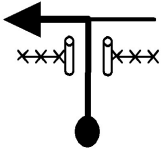

V 27



T11

45

SEDE LAMA NA VEIA

DESCE

1.83

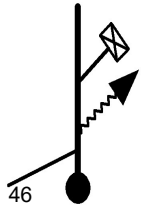

V 27

T11

46

1.91



V 27

T11

47

1.93



V 27

T11

48

2.03

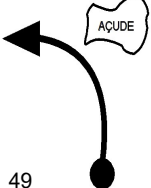



V 27

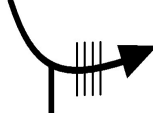

T11

49

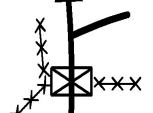
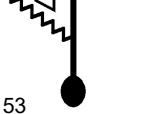
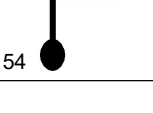
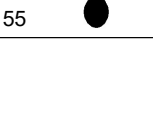
2.21	
V 12 00.11.26	50
T12	DEVAGAR
2.34	
V 12	51
T12	
2.44	
V 39 00.12.35	52
T13	
2.86	
V 39	53
☠☠ T13	
2.94	
V 39	54
T13	
3.28	
V 39	55
☠☠ T13	

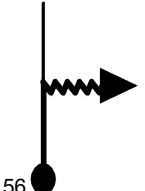
3.41	
V 21 00.14.04	
T14	56

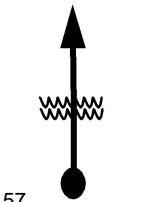
3.69	
V 21	
T14	57

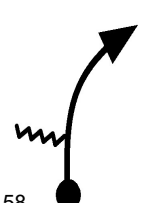
3.73	
V 21	
T14	58

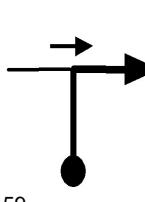
4.24	
V 39 00.16.26	
T15	59



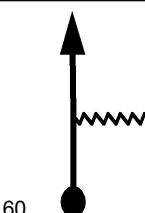

4.70	
V 39	
T15	60

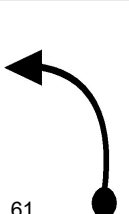
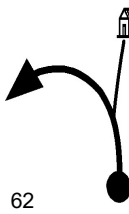
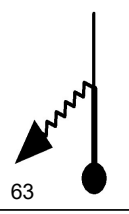
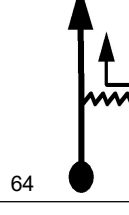
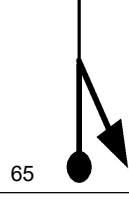
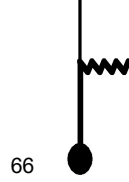
CURVA PERIGOSA

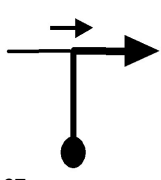
4.91	
V 39 T15	
5.07	
V 21 00.17.43 T16	
5.48	
V 21 T16	
5.57	
V 21 T16	
5.59	
V 21 T16	
5.61	
V 21 T16	

5.62	
V 21	
T16	67

5.64	
V 21	
T16	68

5.67	
V 21	
T16	69

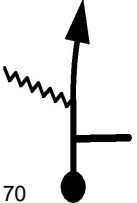
6.01	
V 21	
T16	70

6.17	
N2'30s 00.20.52	
T17	71

EUCALIPTO

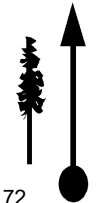
6.17	
V 12 00.23.22	
T18	72

GUIDADO

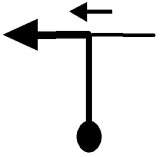
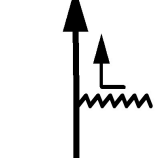
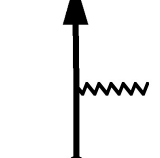
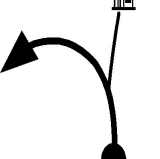
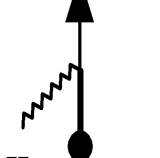
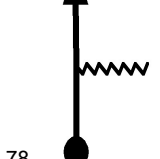
6.19	
V 39 00.23.28 ☠️ T19	73
6.26	
V 39 T19	74
6.73	
V 39 T19	75
7.09	
V 21 00.24.51 T20	76
7.51	
V 21 T20	77
7.57	
V 30 00.26.13 T21	78

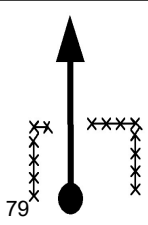
8.14	
V 30	
T21	

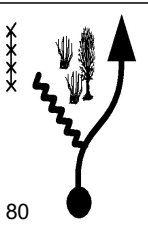
8.25	
V 30	
T21	

PEDRAS



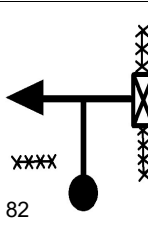

PELA TRILHA GADO

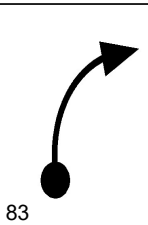

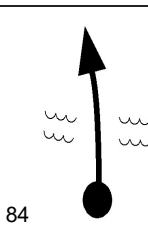

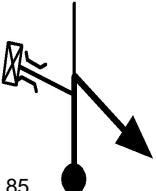

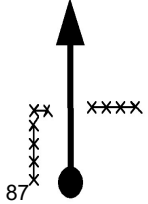
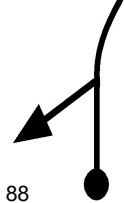
8.28	
V 30	
T21	

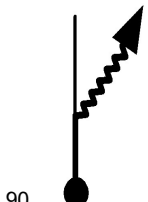

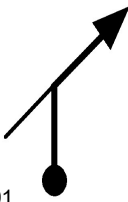

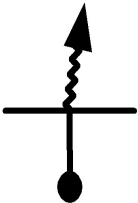

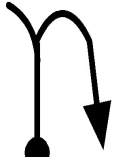
8.37	
V 30	
T21	





8.48	
V 30	
T21	

8.54	
V 30	
T21	

8.64	
V 33 00.28.21	85
8.70	
V 33	86
8.98	
V 33	87
9.17	
V 30 00.29.19	88
T22	ATOLEIRO
T23	PELA ESQUERDA
9.19	
V 30	89
9.33	
V 30	90
T23	

9.35	
V 30	
T23	91
CEPO	
9.39	
V 30	
T23	92
9.48	
0.00	
V 18 00.29.56	
T24	93
0.15	
V 18	
T24	94
0.25	
V 18	
T24	95
0.51	
V 18	
T24	96

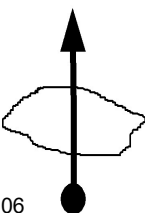
0.60	
V 18	97
0.70	
V 18	98
0.87	
V 18	99
1.20	
V 18	100
1.37	
V 18	101
1.40	
V 18	102

1.44	
V 18	
T24	103
1.66	
V 18	
T24	104
1.68	
N2'30s 00.35.32	
T25	105
LAJE PEDRA	
1.68	
V 30 00.38.02	
T26	106
BAMP	
1.75	
V 30	
T26	107
BANHADO	
1.83	
V 30	
T26	108

BAMP

1.93



V 30

T26

109

2.04

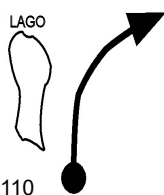

V 30

T26

110

2.13



V 30

T26

111

2.26



V 30

T26

112

2.37



V 30

T26

113

BAMP

2.65

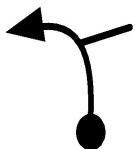

V 30

T26

114

BAMP

2.68

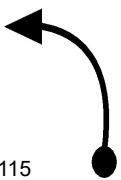

V 30

T26

115

2.72

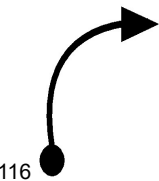

V 30

T26

116

2.83

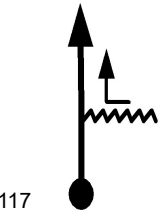

V 30

T26

117

VALO

3.00

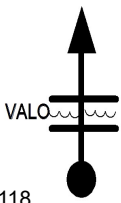

V 36 00.40.41

T27

118

3.08

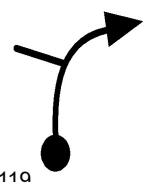

V 36

T27

119



3.21



V 36

T27

120

3.36	
V 36	
T27	121

3.44	
V 36	
T27	122

SUBIDA EROSÕES

3.71	
V 36	
T27	123

3.96	
V 36	
T27	124

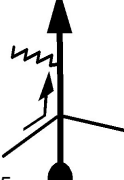
4.12	
V 36	
T27	125

4.58	
V 36	
T27	126

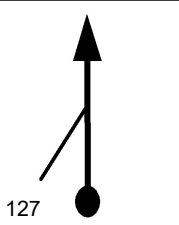
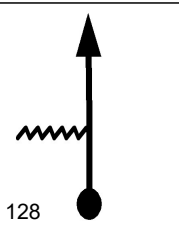
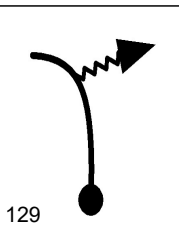
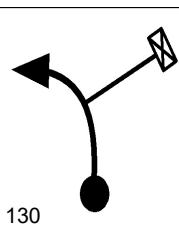
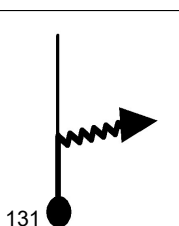
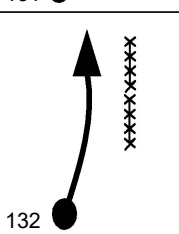
4.66	
V 36	
T27	127
4.79	
V 36	
T27	128
4.81	
V 18 00.43.42	
T28	129
5.03	
V 18	
T28	130
5.07	
V 18	
T28	131
5.17	
V 18	
T28	132

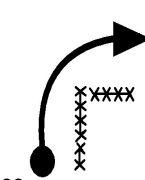
5.29	
V 15 00.45.18	
T29	133

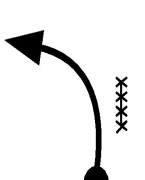
5.31	
V 15	
T29	134

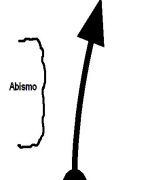

CUIDADO



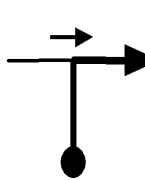

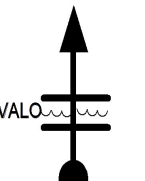
5.48	
V 15	
T29	135

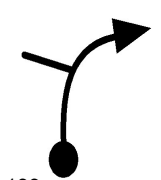
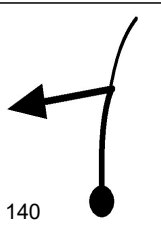
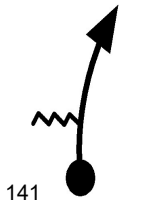
5.59	
N2'30s 00.46.30	
T30	136

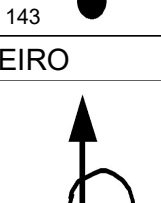
5.59	
V 30 00.49.00	
T31	137

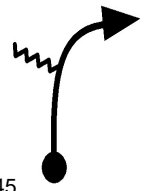
5.77	
V 36 00.49.21	
T32	138

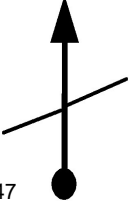
5.84	
V 36	
T32	139
5.97	
V 36	
T32	140
6.12	
V 36	
T32	141
6.20	
V 21 00.50.04	
T33	142
NO MATO	
6.34	
V 21	
T33	143
ATOLEIRO	
6.64	
V 18 00.51.20	
T34	144

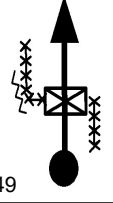
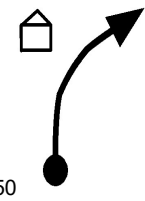
6.71	
V 18	
T34	145
6.89	
V 18	
T34	146
6.99	
V 30 00.52.30	
T35	147
7.12	
V 30	
T35	148
7.23	
V 30	
T35	149
7.43	
V 30	
T35	150

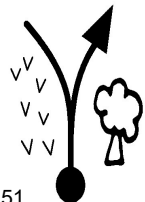
7.55	
V 30	
T35	151

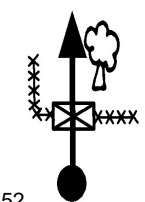
7.57	
V 30	
T35	152

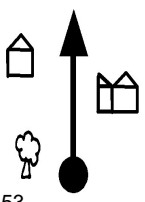
7.67	
V 30	
T35	153

7.70	
N 3' 00.53.55	
T36	154

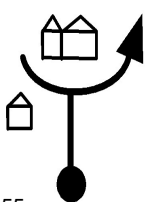
7.70	
V 33 00.56.55	
T37	155

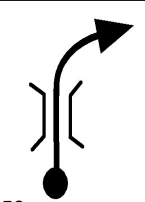
7.90	
V 33	
T37	156

8.01

V 42 00.57.29

T38 157

8.22

0.00

V 42 00.57.47

T39 158

0.16

V 18 00.58.00

T40 159

0.26

V 18

T40 160

BAMP

0.31

V 18

T40 161

0.36

V 18

T40 162

0.38	
N 30s 00.58.44	
T41	163

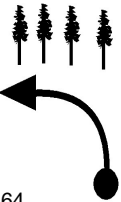
0.38	
V 39 00.59.14	
T42	164

PINHEIRO

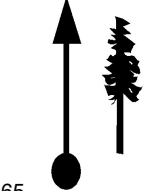

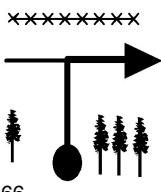

0.50	
V 39	
T42	165

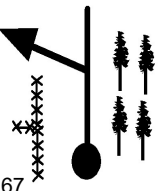
SECAR A VELA

0.58	
V 45 00.59.33	
T43	166

0.62	
V 45	
T43	167

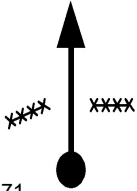
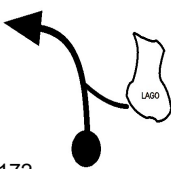
0.70	
V 45	
T43	168

1.18	
V 45	
T43	169
1.36	
V 45	
T43	170
1.55	
V 45	
T43	171
1.71	
V 27 01.01.03	
T44	172
1.78	
N 1' 01.01.13	
T45	173
1.78	
V 36 01.02.13	
T46	174

2.24	
V 36	
T46	175

2.33	
V 36	
T46	176

2.45	
V 18 01.03.20	
T47	177

CUIDADO





DESCE



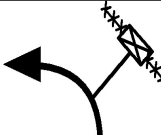
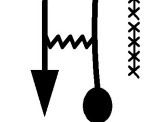

2.56	
V 18	
T47	178



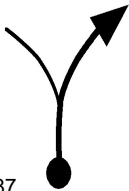

2.71	
V 36 01.04.12	
 T48	179

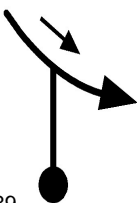
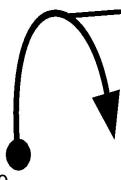
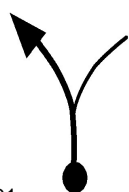

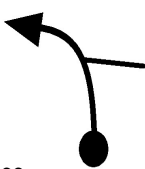
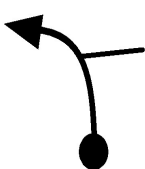

2.79	
V 36	
T48	180

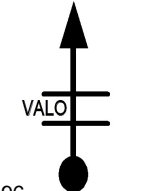

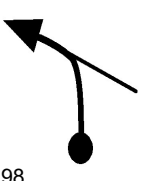

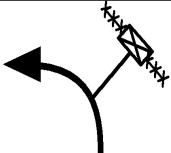
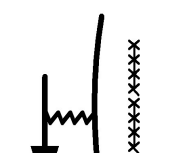
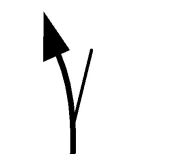
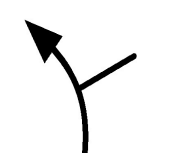
3.07	
V 36	181
T48	
3.44	
V 36	182
T48	
3.56	
V 36	183
T48	
3.82	
V 36	184
T48	
3.95	
V 36	185
T48	
4.08	
V 36	186
T48	

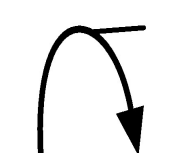

4.32	
V 36	
T48	187
4.52	
V 36	
T48	188
4.62	
V 36	
T48	189
4.75	
V 36	
T48	190
4.98	
V 36	
T48	191
PONTE LISA	
5.11	
V 36	
T48	192

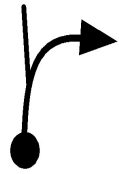
5.20	
V 36 T48 193	
5.60	
V 36 T48 194	
5.79	
N 1' 01.09.20 T49 195	
5.79	
V 36 01.10.20 T50 196	
5.84	
V 36 T50 197	
5.92	
V 36 T50 198	

6.20	
V 36	T50 199
6.56	
V 36	T50 200
6.68	
V 36	T50 201
6.94	
V 36	T50 202
7.07	
V 36	T50 203
7.20	
V 36	T50 204

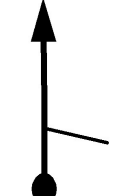
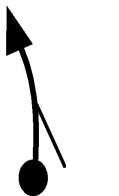
7.44	
V 36	
T50	205
7.64	
V 21 01.13.25	
T51	206
7.72	
V 21	
T51	207
7.79	
V 21	
T51	208
7.81	
V 21	
T51	209
7.87	
V 21	
T51	210

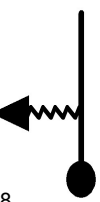
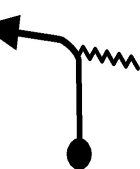
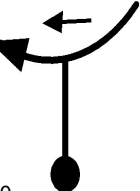
8.01	
V 21	
T51	211
8.21	
V 21	
T51	212
8.27	
V 21	
T51	213
SUBIDA	
8.38	
V 30 01.15.32	
T52	214
8.45	
V 30	
T52	215
8.51	
V 30	
T52	216

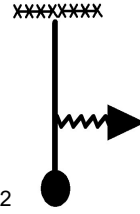
8.55	
V 30	T52 217
8.57	
V 30	T52 218
8.62	
V 30	T52 219
8.67	
V 30	T52 220
8.70	
V 30	T52 221
8.80	
V 15 01.16.22	T53 222

8.84
 V 15
 T53 223

8.86
 V 15
 T53 224

8.90
 N2'30s 01.16.46
 T54 225

8.90
 V 15 01.19.16
 T55 226

PORTÃO CIRSURES

9.21
 V 42 01.20.30
 T56 227

☠☠☠

9.68
 V 42
 T56 228

INICIO CALÇAMENTO

9.89

V 42

T56

229

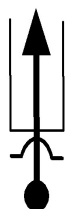

9.95

V 42

T56

230

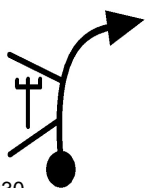

10.01

V 42

T56

231

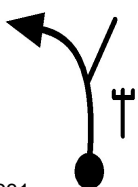

10.38

V 42

T56

232

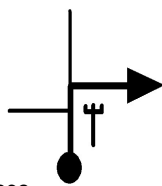

PISTA SKATE

10.46

V 42

T56

233

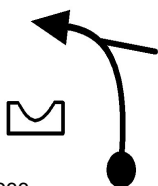

10.51

N 19' 01.22.22

T57

234



10.51	
0.00	
V 42 01.41.22	
T58	235
INICIO 2ª ETAPA	
ZERAR NO POSTE	
0.00	
V 42	
T58	
0.01	
V 42	
T58	
0.04	
V 42	
T58	
0.15	
V 42	
T58	
	239



MERCADO FONTANA

0.46

V 42

T58

240



0.78

V 42

T58

241



FINAL CALÇAMENTO

1.00

V 42

T58

242

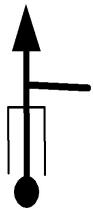

1.70

V 42

T58

243



2.40

V 30 01.44.47

T59

244

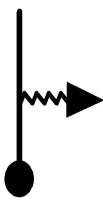

COSTEAR MATO

2.85



V 21 01.45.41

T60 245

3.00



V 21

T60 246

3.02



V 21

T60 247

3.15



V 21

T60 248

3.29

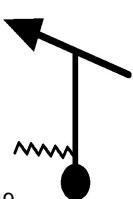

V 21

T60 249



TRILHA DA TANGA

3.31

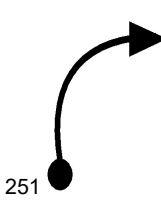
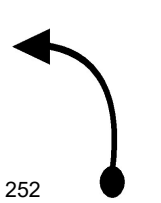
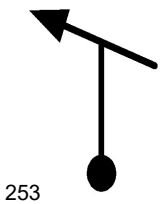
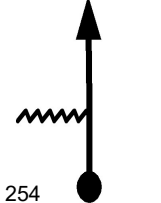

V 21

T60 250

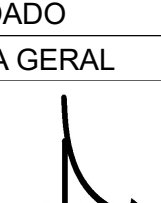
3.36	
V 30 01.47.09	
T61	251
3.52	
V 30	
T61	252
3.84	
V 30	
T61	253
3.89	
V 24 01.48.12	
T62	254
4.05	
N2'30s 01.48.36	
T63	255
CUIDADO	
ESTRADA GERAL	
4.05	
V 27 01.51.06	
T64	256

SUBIDA PEDRA

ACELERE FORTE

4.12



V 27

 T64

257

4.39

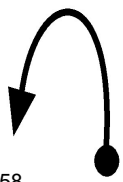

V 27

T64

258

4.58

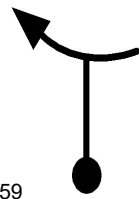

V 30 01.52.17

T65

259

4.69



V 30

T65

260

4.78

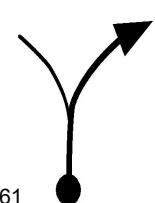

V 21 01.52.41

T66

261

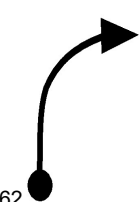

4.89



V 21

T66

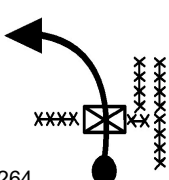
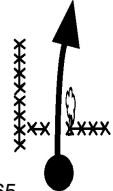
262

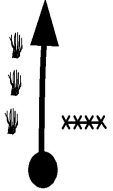
5.01	
V 21	
T66	263
5.06	
V 18 01.53.29	
T67	264
5.19	
V 18	
T67	265
5.21	
V 18	
T67	266
COSTEAR MATO	
5.24	
V 18	
T67	267
5.27	
V 18	
T67	268

5.32

V 27 01.54.21

T68 269

COSTEAR CERCA

5.44

V 27

T68 270

BAMP

5.47

V 27

T68 271

5.52

N 2' 01.54.48

T69 272

5.52

V 27 01.56.48

T70 273

5.60

V 36 01.56.58

T71 274

5.75	
V 36	
T71	275
6.15	
V 36	XXXXX
T71	276
6.27	
V 42 01.58.05	
T72	277
6.67	
V 42	
T72	278
7.07	
V 42	
T72	279
7.51	
V 42	
T72	280

7.93	←	XXX ⊠ XXX
V 42	●	
T72	281	
8.31	↗	
V 42	●	
T72	282	
9.09	↖	
0.00	●	
V 27 02.02.07		
T73	283	
0.08	↖	
V 27	●	
T73	284	
0.10	↑	
V 27	●	
T73	285	
CUIDADO CABEÇA		
0.14	↑	
V 27	●	
T73	286	

0.32	
V 27	
T73	287

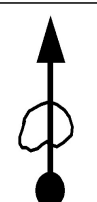
0.40	
V 21 02.03.00	
T74	288

DESCIDA
CUIDADO

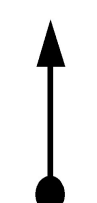

0.50	
V 21	
T74	289

0.83	
V 21	
T74	290

1.05	
V 21	
T74	291

CUIDADO
NÃO ERRE

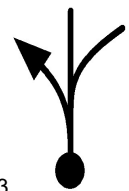
1.12	
V 21	
T74	292

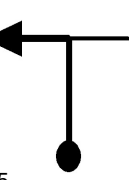
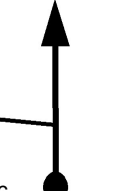
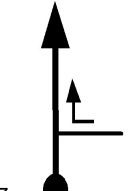
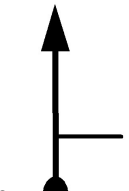
1.13	
V 27 02.05.06	293
1.32	
V 27	294
1.36	
V 27	295
1.39	
V 27	296
1.43	
V 27	297
1.53	
V 27	298

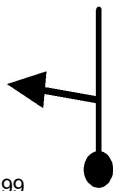
1.66	
V 24 02.06.16	
T76	299

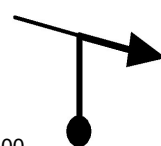

1.97	
V 24	
T76	300

2.02	
V 24	
T76	301

2.12	
V 24	
T76	302

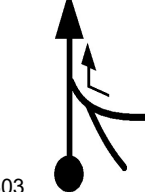
2.31	
V 27 02.07.54	
T77	303

2.34

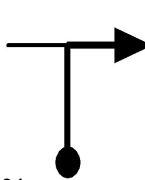

V 27

T77 304

2.38

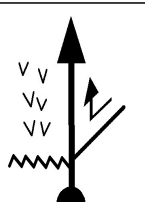

V 27

T77 305

2.54

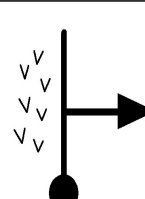

V 27

T77 306

2.62

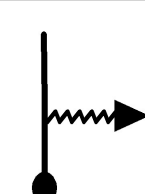

V 24 02.08.35

T78 307

2.76

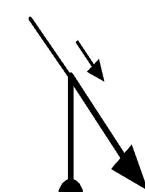

V 27 02.08.56

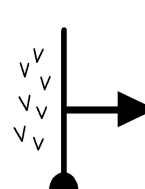

T79 308

2.92





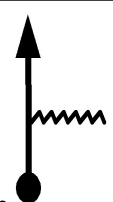

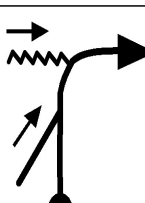
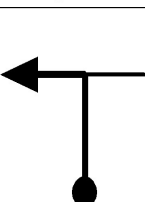
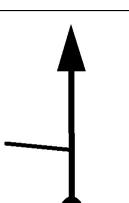
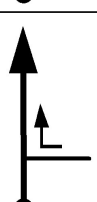
V 27

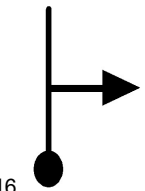
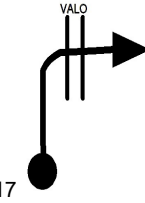
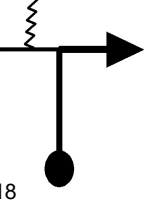
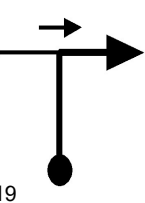
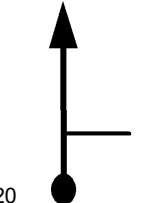
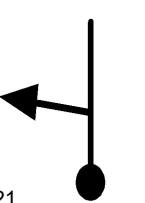
T79 309

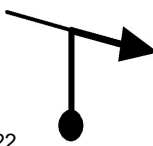
2.99	
V 27	
T79	310
3.05	
V 24 02.09.35	
T80	311
3.23	
V 27 02.10.02	
T81	312
3.27	
V 27	
T81	313
3.30	
V 27	
T81	314
3.33	
V 27	
T81	315

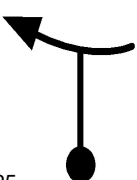
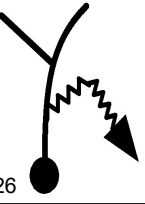
3.43	
V 24 02.10.28	316
3.54	
V 24	317
3.63	
V 24	318
3.74	
V 27 02.11.15	319
3.84	
V 27	320
3.97	
V 24 02.11.46	321

4.29	
V 24	
T84	322
4.33	
V 24	
T84	323
4.43	
V 24	
T84	324
4.71	
V 24	
T84	325
4.78	
V 15 02.13.47	
T85	326
ACELERE	
4.83	
V 15	
T85	327

DESCIDA

GUIDADO

4.95

V 15

T85

328

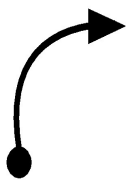

4.99

V 15

T85

329

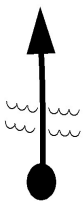

5.03

V 15

T85

330



5.18

V 15

T85

331



5.24

V 21 02.15.37

T86

332

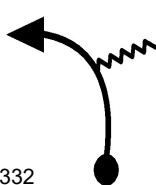

5.29





V 21

T86

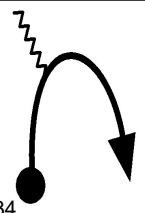
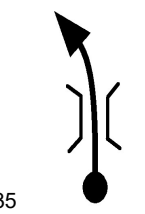
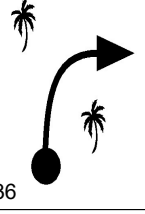
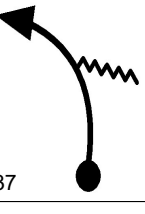
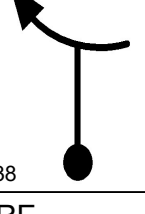
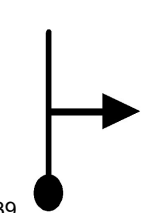
333

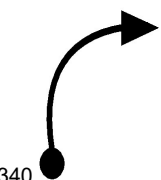

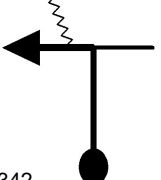
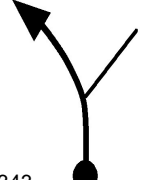
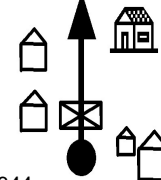
5.62	
V 21	
T86	334
5.75	
V 21	
T86	335
5.94	
V 21	
T86	336
6.01	
V 21	
T86	337
6.02	
V 27 02.17.51	
T87	338
ACELERE	
6.18	
V 27	
T87	339

6.42	
V 27	
T87	340
6.55	
N 4' 02.19.02	
T88	341
6.55	
V 30 02.23.02	
T89	342
6.70	
V 30	
T89	343
6.97	
V 12 02.23.52	
T90	344
7.00	
V 12	
T90	345

7.09	
V 12	
T90	346
ESTRADA GERAL	
7.18	
V 36 02.24.55	
T91	347
7.23	
V 36	
T91	348
7.75	
V 36	
T91	349
7.99	
V 36	
T91	350
8.06	
V 21 02.26.23	
T92	351

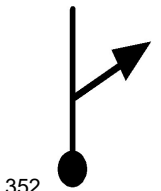
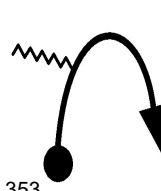
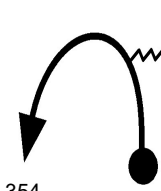
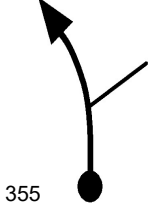
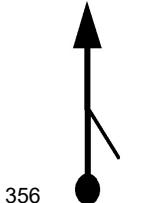
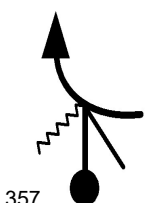
8.19	
V 21	
T92	352
8.35	
V 21	
T92	353
8.48	
V 21	
T92	354
8.55	
V 27 02.27.47	
T93	355
8.65	
V 27	
T93	356
8.73	
V 27	
T93	357

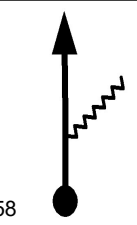
8.87	
V 27	
T93	358

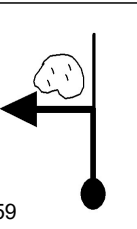
9.28	
V 30 02.29.25	
T94	359



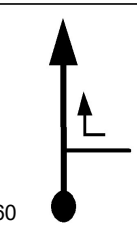

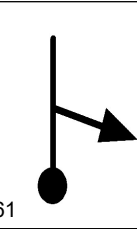

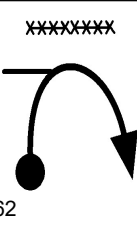

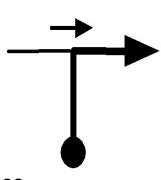
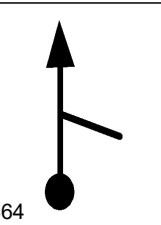
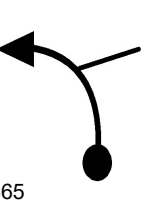
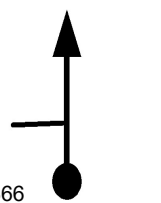
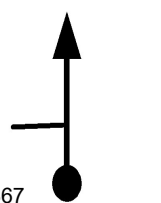
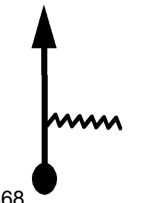
9.33	
V 30	
T94	360

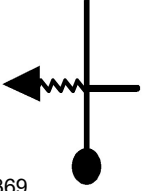
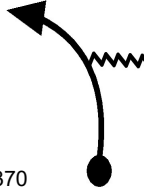
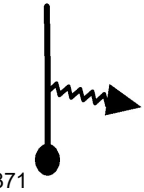
9.42	
V 30	
T94	361

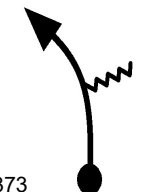
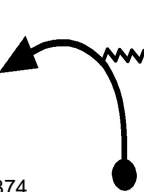
9.57	XXXXXXXX 
V 30	
T94	362



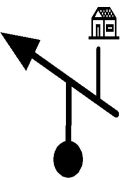
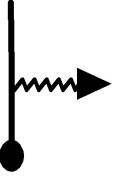
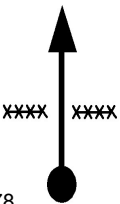

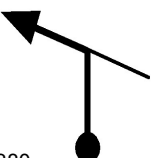

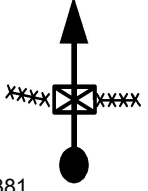
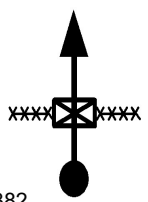
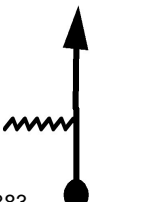
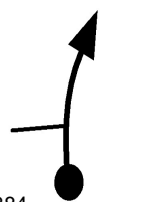
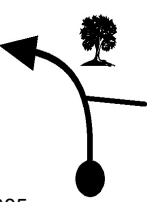
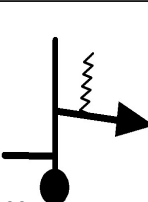
9.72	
V 30	
T94	363
9.82	
V 30	
T94	364
9.84	
V 30	
T94	365
10.14	
V 30	
T94	366
10.21	
V 30	
T94	367
10.24	
V 30	
T94	368

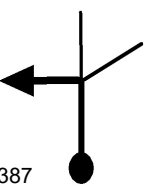
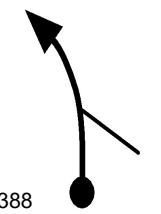
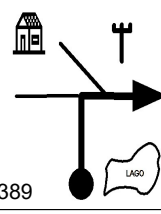
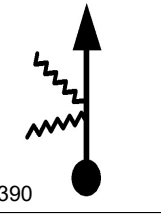
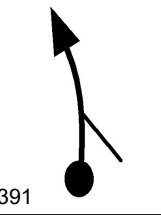
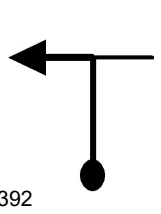

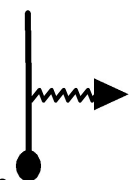

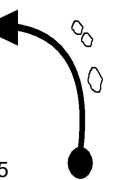
10.32	
V 27 02.31.29	
T95	369
10.71	
V 27	
T95	370
10.73	
V 27	
T95	371
10.82	
V 27	
T95	372
10.88	
V 27	
T95	373
11.03	
V 27	
T95	374

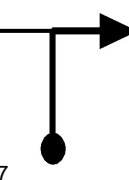
11.13	
N 2' 02.33.17	
T96	375
11.13	
0.00	
V 21 02.35.17	
T97	376
0.05	
V 21	
T97	377
0.10	
V 21	
T97	378
0.14	
V 21	
T97	379
0.23	
V 21	
T97	380

0.24	
V 21	
T97	381
0.33	
V 21	
T97	382
0.35	
V 21	
T97	383
0.46	
V 21	
T97	384
0.51	
V 21	
T97	385
0.61	
V 18 02.37.02	
T98	386

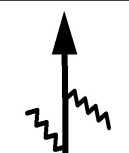
0.66	
V 18	
T98	387
0.74	
V 18	
T98	388
0.81	
V 18	
T98	389
0.84	
V 36 02.37.48	
T99	390
0.93	
V 36	
T99	391
ESTRADA GERAL	
1.23	
V 36	
T99	392

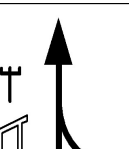
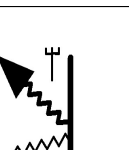
1.27	
V 18 02.38.31	
T100	393
DEGRAU PEDRA	
1.61	
V 18	
T100	394
1.82	
V 18	
T100	395
1.93	
V 18	
T100	396
1.98	
V 36 02.40.53	
 T101	397
2.03	
V 39 02.40.58	
T102	398

2.10	
V 39	
T102	399
2.60	
V 39	
T102	400
3.11	
V 39	
T102	401
3.79	
V 39	
T102	402
4.08	
V 33 02.44.07	
T103	403
4.26	
V 33	
T103	404

TRILHA DRENO

4.35

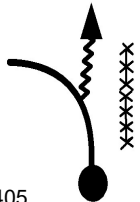

V 21 02.44.37

T104 405

4.42



V 21

T104 406

4.50



V 21

T104 407

4.64



V 12 02.45.26

T105 408

4.68

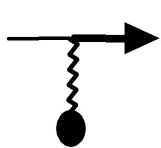

V 21 02.45.38





T106 409

5.18

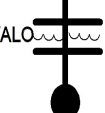

V 12 02.47.04

T107 410

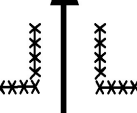
5.19	
V 18 02.47.07	
T108	411
5.43	
V 18	
T108	412
5.78	
V 18	
T108	413
5.79	
NI'30s 02.49.07	
T109	414
COSTEAR CERCA	
5.79	
V 30 02.50.37	
T110	415
5.86	
V 30	
T110	416

5.91	
V 30	
T110	417

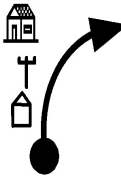
6.10	
V 30	
T110	418

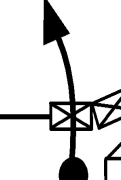
6.16	
V 30	
T110	419

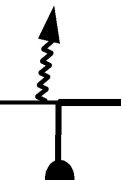

6.17	
V 36 02.51.23	
T111	420

6.45	
V 36	
T111	421

BARRANCO

POR BAIXO

6.88

V 27 02.52.34

T112

422



6.95

V 27

T112

423



6.97

V 27

T112

424

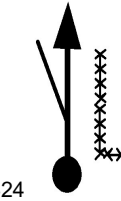

7.04

V 12 02.52.55

T113

425



7.07

V 12

T113

426

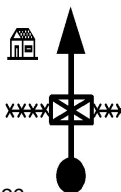

7.11

V 12

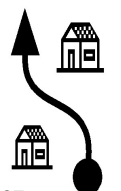

T113

427

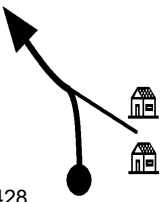
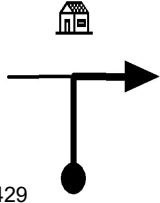
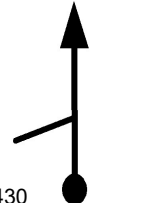
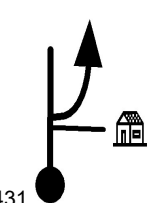
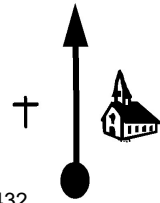
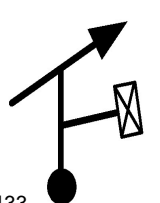

7.19	
V 33 02.53.40	428
7.30	
V 42 02.53.52	429
7.40	
V 42	430
7.42	
V 42	431
7.49	
V 42	432
7.57	
V 45 02.54.15	433

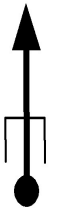
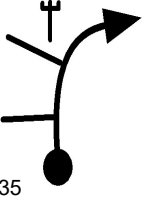
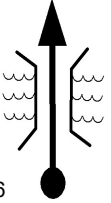
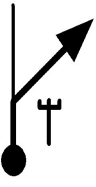
FINAL CALÇAMENTO

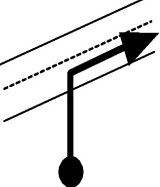
<p>7.78</p> <p>V 45</p> <p>T116 434</p>	
<p>7.88</p> <p>V 45</p> <p>T116 435</p>	
<p>8.27</p> <p>V 45</p> <p>T116 436</p>	
<p>8.64</p> <p>V 45</p> <p>T116 437</p>	
<p>9.00</p> <p>N 1' 02.56.10</p> <p>T117 438</p>	
<p>9.00</p> <p>0.00</p> <p>V 51 02.57.10</p> <p> T118 439</p>	

1.19	
V 51	
T118 440	

1.32	
V 51	
T118 441	

FINAL ASFALTO

1.64	
V 36 02.59.05	
T119 442	

1.86	
V 30 02.59.27	
T120 443	

1.89	
V 30	
T120 444	

COSTEAR MATO

2.16	
V 30	
T120 445	

2.37

V 30

T120 446

2.46

V 30

T120 447

2.57

V 30

T120 448

2.61

V 30

T120 449

2.65

V 30

T120 450

2.67

V 30

T120 451

NO MATO

2.72



V 30 03.01.10

T121 452

3.16

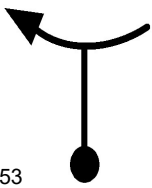

V 30

T121 453

SENTIDO PINHEIROS

3.45

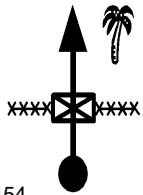

V 30

T121 454

3.64



NI'30s 03.03.01

T122 455

3.64



V 33 03.04.31



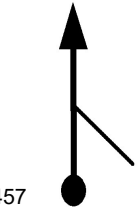

T123 456



3.69

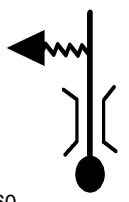
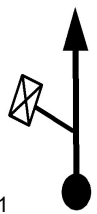

V 33

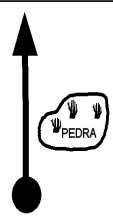
T123 457

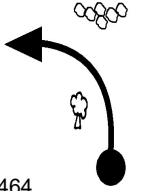
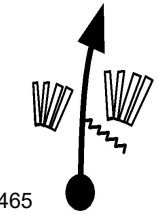
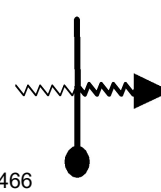
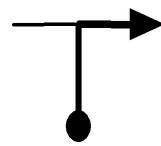
3.74	
V 33	
T123	458
3.98	
V 33	
T123	459
4.06	
V 24 03.05.17	
T124	460
4.10	
V 24	
T124	461
4.22	
V 24	
T124	462
4.37	
V 18 03.06.03	
T125	463

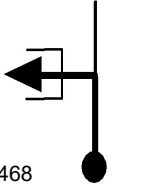
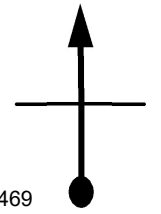
4.44	
V 18	464
4.47	
V 30 03.06.23	465
4.74	
V 12 03.06.56	466
4.78	
V 30 03.07.08	467
	T128
INÍCIO ASFALTO	
4.82	
V 39 03.07.12	468
4.88	
V 39	469
T129	

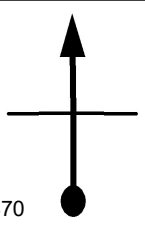
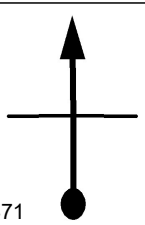
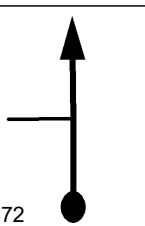
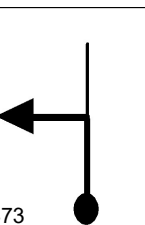
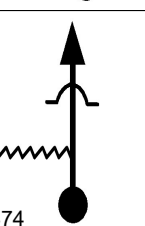
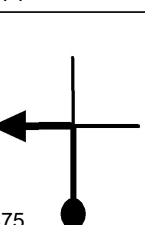
4.94	
V 39	
T129	470
5.00	
V 39	
T129	471
5.07	
V 39	
T129	472
5.22	
V 39	
T129	473
5.41	
V 39	
T129	474
5.56	
V 39	
T129	475

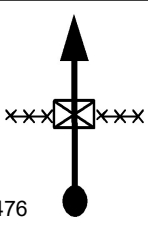
5.68	
V 24 03.08.32	
T130	476

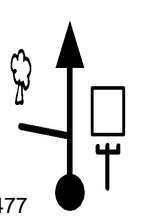
5.70	
V 24	
T130	477

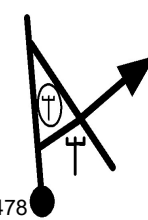
5.72	
V 24	
T130	478

RESTAURANTE

GRANITÃO

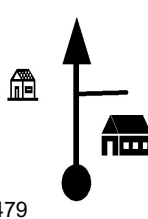
5.78	
V 24	
T130	479

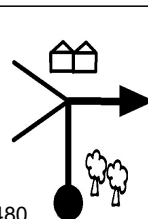

5.81	
V 24	
T130	480

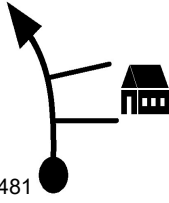
5.83	
V 24	
T130	481

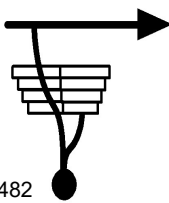
5.86	
V 24	
T130	482

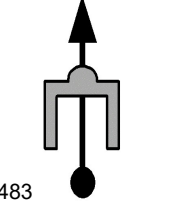
5.89	
V 24 03.09.03	
T130	483

FIM DE PROVA !!



www.t15.com.br

Tempo de Prova

MÉDIA C 03:09:03

FIM