

INICIO

MÉDIA C

5º Enduro Amigos na Trilha
14/07/2018



IMPORTANTE

PLANILHA TERMICA
FITA ADESIVA DO LADO DE
TRÁS. NÃO USE CANETA
MARCA TEXTO,
USE CANETA ESFEROGRÁFICA
OU HIDROGRÁFICA

DIRETORES DE PROVA:
DIOGES OSELLAME
DIONATAN OSELLAME

REALIZAÇÃO:
EQUIPE AMIGOS NA TRILHA

NOS TRECHOS URBANOS
PREVALECEM AS LEIS DO
CÓDIGO NACIONAL DE
TRANSITO. É OBRIGAÇÃO
RESPEITAR AS PROPRIEDADES
ALHEIAS E OS MORADORES.
A ORGANIZAÇÃO NÃO SE
RESPONSABILIZA POR PASSAR
PROGRAMAÇÃO DE NAVEGAÇÃO.
É OBRIGAÇÃO DO PILOTO
CONFERIR A PROGRAMAÇÃO DO
NAVEGADOR.

LARGADA - 14:00 HS
CTG TIO MILLO
NEUTRO PRINCIPAL RANCHO DO CAVALO VELHO - SIDEROPOLIS
CHEGADA NO MESMO
LOCAL DA LARGADA

1 ETAPA KM 40,79
2 ETAPA KM 31,37
TOTAL KM 72,16

LEVANTAMENTO DA PROVA
COM MOTO CRF 230F COM
PNEU DIANTEIRO BOM
E 12 LIBRAS

☠️ CUIDADO
☠️☠️ ATENÇÃO
☠️☠️☠️ MUITA ATENÇÃO

Tempo de Prova

MÉDIA C 03:05:18



AFERIÇÃO

Aferição

0.00

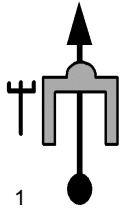

AFER

1

0.25



AFER

2

0.36

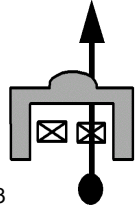

AFER

3

0.38

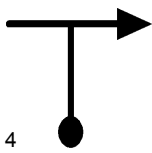

AFER

4

0.64	
AFER	5

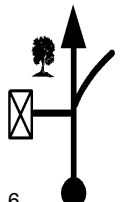
1.80	
AFER	6

Aferir!
Retorne com Cuidado!

2.269	
0.00	
AFER	7





INICIO DE PROVA

Inicio da Prova

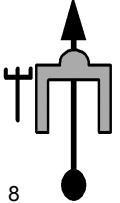
Boa Sorte !

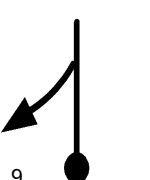
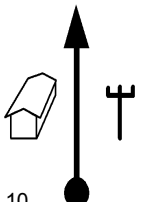
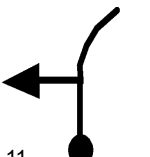
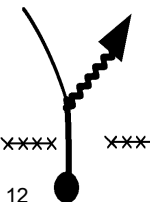
0.00	
V 25 00.00.00	
T1	8

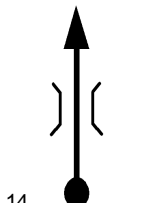
<p>0.25</p> <p>V 25 00.00.36</p> <p>T1</p>	 <p>9</p>
<p>0.42</p> <p>V 25 00.01.00</p> <p>T1</p>	 <p>10</p>
<p>0.56</p> <p>V 25 00.01.21</p> <p>T1</p>	 <p>11</p>
<p> siga bamp</p>	
<p>0.61</p> <p>V 30 00.01.28</p> <p>T2</p>	 <p>12</p>
<p> Bamp!</p>	
<p>0.65</p> <p>V 30 00.01.33</p> <p>T2</p>	 <p>13</p>
<p> ATENÇÃO!!</p>	
<p>0.77</p> <p>V 30 00.01.47</p> <p>T2</p>	 <p>14</p>

Bamp!

1.31

V 30 00.02.52

T2

15

Bamp!

1.50

V 30 00.03.15

T2

16

Bamp

1.54

V 30 00.03.19

T2

17

Cuidado Estrada Geral!

1.63

N 1' 00.03.30

T3

18

1.63

V 35 00.04.30

T4

19

2.01	
V 35 00.05.09	20
T4	

2.29	
V 33 00.05.38	21
T5	

2.51	
V 33 00.06.02	22
T5	

Atenção

2.64	
V 33 00.06.16	23
T5	

2.75	
V 33 00.06.28	24
T5	

Cuidado! Estrada Geral!!!

2.96	
N30s 00.06.51	25
 T6	

2.96	
V 33 00.07.21	26
T7	

moto contra

3.07	
V 33 00.07.33	27
T7	

3.17	
V 33 00.07.44	28
T7	

cuidado

3.33	
V 33 00.08.02	29
T7	





escolha o melhor lugar!





3.41	
V 21 00.08.10	30
T8	

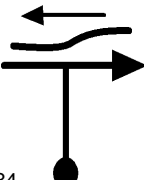
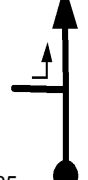

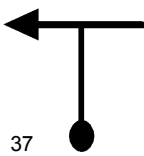

Atenção Pela Direita!!!

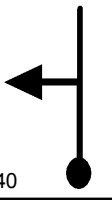
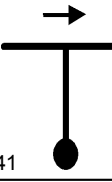



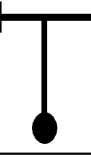

Se entrar no atoleiro
não sai mais!!!

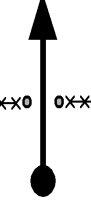
3.46	
V 21 00.08.19	31
T8	

3.48	
V 33 00.08.22 T9	32
3.65	
V 33 00.08.41 T9	33
3.86	
V 33 00.09.04 T9	34
4.04	
V 33 00.09.23 T9	35
4.26	
N30s 00.09.47 T10	36
4.26	
V 33 00.10.17 T11	37

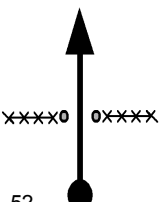
4.37	
V 33 00.10.29 T11	38
4.59	
V 33 00.10.53 T11	39
4.71	
V 33 00.11.06 T11	40
cuidado!	
4.79	
V 33 00.11.15 ☠☠☠ T11	41
4.84	
V 21 00.11.21 T12	42
4.89	
V 21 00.11.29 T12	43

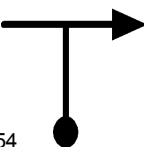
4.91	
V 33 00.11.33 T13	44
5.09	
V 33 00.11.52 T13	45
5.42	
V 33 00.12.28 T13	46
5.66	
V 33 00.12.54 T13	47
Bamp!	
5.81	
V 33 00.13.11 T13	48
6.03	
V 33 00.13.35 T13	49

6.43	
V 33 00.14.18 T13	50
6.72	
V 44 00.14.50 T14	51
6.74	
V 44 00.14.52 T14	52
6.78	
V 44 00.14.55 T14	53
6.84	
V 44 00.15.00 T14	54
6.93	
V 30 00.15.07 T15	55

7.00	
V 30 00.15.16	
T15	56

Bamp no eucalipto!

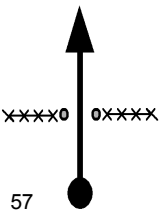
7.13	
V 30 00.15.31	
T15	57

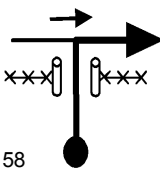

7.20	
V 33 00.15.40	
T16	58

7.36	
V 33 00.15.57	
T16	59

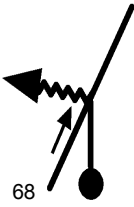

7.64	
V 44 00.16.28	
T17	60

7.66	
V 44 00.16.29	61
T17	
7.71	
V 44 00.16.33	62
T17	
7.76	
V 44 00.16.38	63
T17	
7.86	
V 30 00.16.46	64
T18	
Acelere!	
subida com erosão !!!	
7.93	
V 30 00.16.54	65
T18	
8.38	
V 30 00.17.48	66
T18	

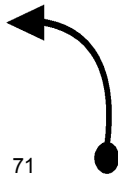
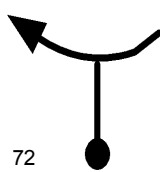
8.43	
NI'30s 00.17.54 T19	67
8.43	
V 27 00.19.24 T20	68
8.52	
V 27 00.19.36 T20	69
8.75	
V 27 00.20.07 T20	70
Acelere!!	
8.87	
V 27 00.20.23 T20	71
Cuidado degrau!!!	
9.11	
V 35 00.20.55 T21	72

9.28	
V 35 00.21.12	
T21	73

9.31	
V 33 00.21.15	
T22	74

Bamp





9.55	
V 33 00.21.42	
T22	75





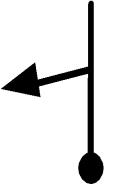

Bamp

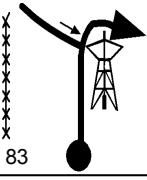
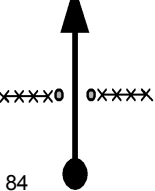

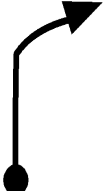

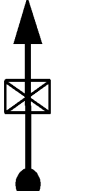
9.61	
V 33 00.21.48	
T22	76

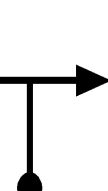
9.71	
V 33 00.21.59	
T22	77

9.99	
V 30 00.22.30	
T23	78

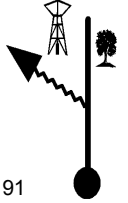
10.06	
0.00	
V 30 00.22.38	
T24	79
0.04	
V 30 00.22.43	
T24	80
0.31	
V 30 00.23.15	
T24	81
Costear Mato!	
0.39	
V 30 00.23.25	
T24	82
0.61	
V 33 00.23.51	
T25	83
0.83	
V 33 00.24.15	
T25	84

1.23	
V 33 00.24.59	
T25	85
1.51	
V 44 00.25.29	
T26	86
1.53	
V 44 00.25.31	
T26	87
1.57	
V 44 00.25.34	
T26	88
1.63	
V 44 00.25.39	
T26	89
1.73	
V 30 00.25.47	
T27	90

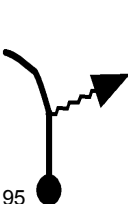
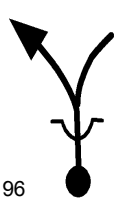
1.79	
V 30 00.25.54 T27	91
2.25	
V 30 00.26.50 T27	92
2.30	
N 1' 00.26.56 T28	93
2.30	
V 30 00.27.56 T29	94
2.56	
V 30 00.28.27 T29	95
Buraco	
2.73	
V 30 00.28.47 T29	96

costear mato

na direita

bamp

2.76

V 30 00.28.51

T29

97

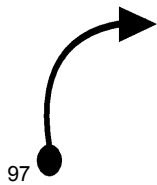

2.80

V 30 00.28.56

T29

98

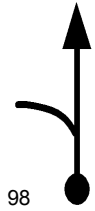

2.93

V 30 00.29.11

T29

99



2.99

V 30 00.29.18

T29

100



3.09

V 39 00.29.30

T30

101

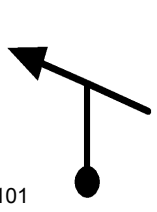







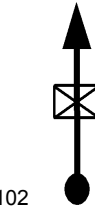

3.51



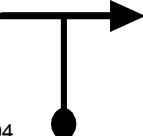

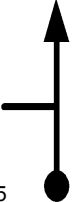
V 39 00.30.09

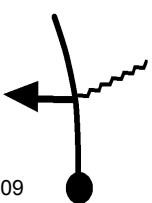
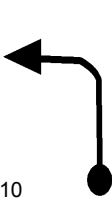

T30

102

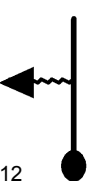

3.52	
N30s 00.30.10	
T31	103
3.52	
V 35 00.30.40	
 T32	104
3.57	
V 35 00.30.45	
T32	105
3.81	
V 33 00.31.10	
T33	106
4.01	
V 33 00.31.32	
T33	107
4.59	
V 33 00.32.35	
T33	108

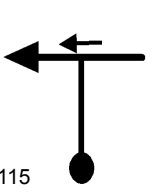
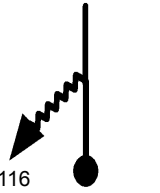
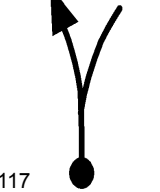
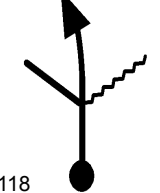
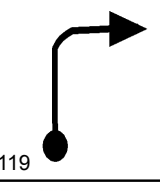
4.67	
V 27 00.32.44	
T34	109
5.03	
V 27 00.33.32	
T34	110
Escolha	
5.12	
V 27 00.33.44	
T34	111
entrada escondida !!	
5.13	
V 24 00.33.45	
T35	112
5.69	
V 24 00.35.09	
T35	113
5.85	
N 1' 00.35.33	
T36	114

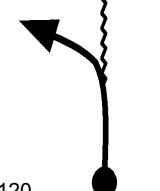
5.85	
V 33 00.36.33	115
T37	
6.09	
V 33 00.36.59	116
T37	
6.30	
V 33 00.37.22	117
T37	
6.97	
V 33 00.38.35	118
T37	
7.11	
V 33 00.38.51	119
T37	
	
7.17	
V 33 00.38.57	120
T37	

Entre no Mato!!!

7.20

V 33 00.39.00

T37

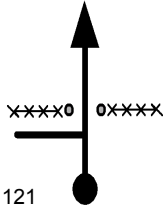

121

7.46

V 33 00.39.29

T37

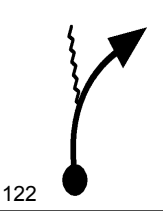

122

7.69

N30s 00.39.54

T38



123

7.69

V 35 00.40.24

T39

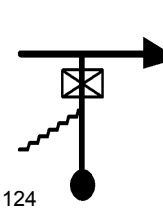

124

8.89

V 35 00.42.27

T39

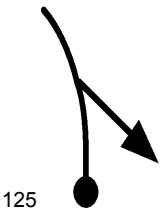

125

10.17

0.00

V 30 00.44.39

T40

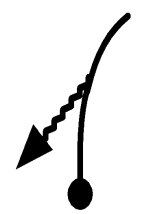

126

Descida com

Erosões!!!!

Cuidado!!

0.32

V 27 00.45.17

 T41

127

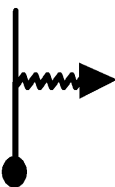

0.98

V 30 00.46.45

T42

128

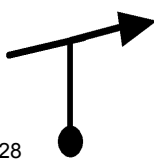

Não erre!!

Se entrar no

atoleiro nao sai mais!

1.26

V 21 00.47.19

T43

129

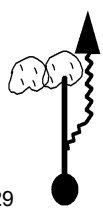

1.28

V 21 00.47.22

T43

130



1.38

N 2' 00.47.40

T44

131



1.38	
V 35 00.49.40	
T45	132

Perigo ponte estreita !!!!!

2.65	
V 35 00.51.50	
☠☠ T45	133

4.29	
V 35 00.54.39	
T45	134

Bamp

4.70	
V 30 00.55.21	
T46	135

4.88	
V 30 00.55.43	
T46	136

4.93	
V 30 00.55.49	
T46	137

4.99	
V 30 00.55.56	
T46	138

5.09	
V 30 00.56.08	
T46	139





trafego de caminhões



5.15	
V 27 00.56.15	
T47	140

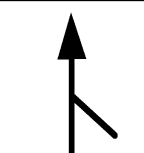

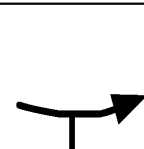
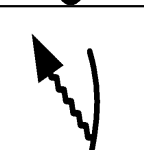
5.55	
V 27 00.57.08	
T47	141

5.60	
V 27 00.57.15	
T47	142

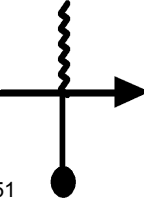
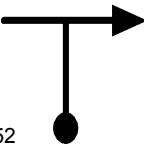
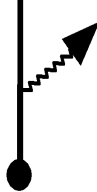
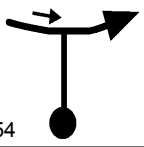
5.65	
V 27 00.57.22	
T47	143

5.71	
V 27 00.57.30 T47	144
6.13	
V 27 00.58.26 T47	145
6.15	
N 1' 00.58.28 T48	146
6.15	
V 30 00.59.28 T49	147
6.41	
V 30 01.00.00 T49	148
6.62	
V 30 01.00.25 T49	149

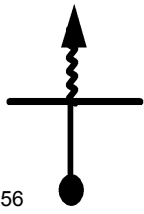
6.88	
V 30 01.00.56	
T49	150
6.97	
V 30 01.01.07	
T49	151
7.03	
V 20 01.01.14	
T50	152
7.36	
V 30 01.02.13	
T51	153
7.40	
V 30 01.02.18	
T51	154
7.66	
V 30 01.02.49	
T51	155

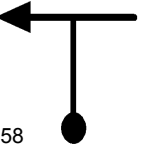
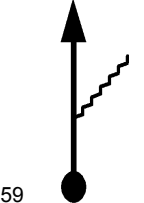
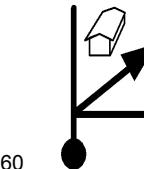
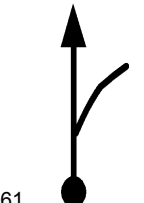
7.75	
V 30 01.03.00	
T51	156
8.08	
N 2' 01.03.40	
T52	157
8.08	
V 35 01.05.40	
T53	158
8.15	
V 35 01.05.47	
T53	159
8.96	
V 35 01.07.10	
T53	160
9.39	
V 35 01.07.54	
T53	161

9.67	
V 35 01.08.23	
T53	162
10.02	
0.00	
V 33 01.08.59	
T54	163
0.32	
V 33 01.09.34	
T54	164
0.41	
V 33 01.09.44	
T54	165
0.52	
V 33 01.09.56	
T54	166
0.56	
V 33 01.10.00	
T54	167

Erosões!!!!!!!

0.68

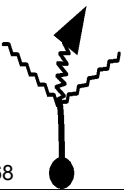

V 30 01.10.13

T55

168

1.33



V 19 01.11.31

T56

169

Escolha o melhor lugar!!!

Perigo!!

1.36



V 19 01.11.37

T56

170

1.51



V 30 01.12.06

T57

171

1.90



V 30 01.12.52

T57

172

Bamp!

2.29

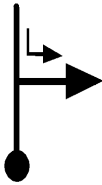

V 30 01.13.39

T57

173

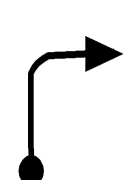

2.47	
V 30 01.14.01	
T57	174

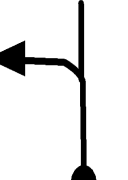
2.52	
V 30 01.14.07	
T57	175

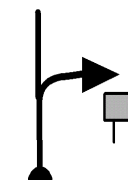
2.58	
V 30 01.14.14	
T57	176

2.68	
V 30 01.14.26	
T57	177

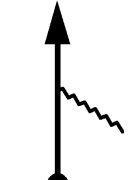
trafego de caminhões

2.74	
V 27 01.14.33	
 T58	178

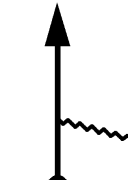
3.06	
V 27 01.15.16	
T58	179



liso!

Acelere

3.14

V 27 01.15.26

T59 180

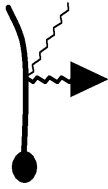

liso

3.25

V 27 01.15.41

 **T59** 181



3.39

V 30 01.16.00

T60 182

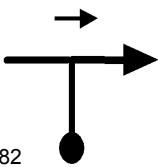









3.46





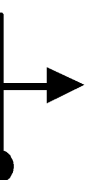
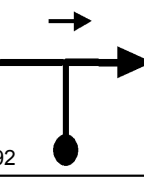
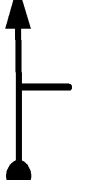

V 30 01.16.08





T60 183





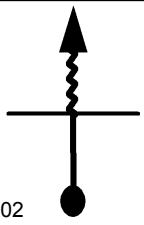

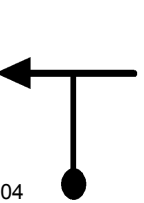

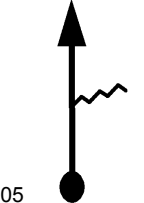
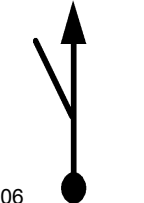
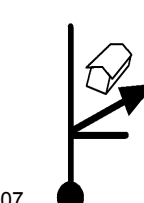

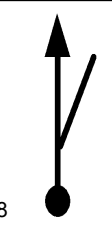
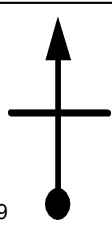

3.53	
V 30 01.16.17	184
T60	
3.58	
V 30 01.16.23	185
T60	
3.65	
V 30 01.16.31	186
T60	
3.71	
V 30 01.16.38	187
T60	
3.78	
V 30 01.16.47	188
T60	
3.81	
V 30 01.16.50	189
T60	

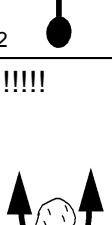

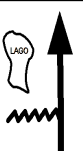

3.88	
V 30 01.16.59	
T60	190
3.94	
V 30 01.17.06	
T60	191
3.98	
V 30 01.17.11	
T60	192
4.05	
V 30 01.17.19	
T60	193
4.15	
V 30 01.17.31	
T60	194
4.46	
V 30 01.18.08	
T60	195

4.53	
N 1' 01.18.17	
 T61	196
4.53	
V 35 01.19.17	
T62	197
4.58	
V 35 01.19.22	
T62	198
4.85	
V 30 01.19.50	
T63	199
5.05	
V 30 01.20.14	
T63	200
5.32	
V 30 01.20.46	
T63	201

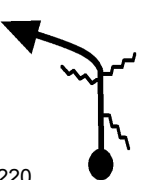
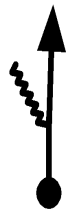

5.42	
V 30 01.20.58	
T63	202
5.73	
N30s 01.21.35	
T64	203
5.73	
V 35 01.22.05	
 T65	204
5.80	
V 35 01.22.12	
T65	205
6.36	
V 35 01.23.10	
T65	206
6.61	
V 35 01.23.36	
T65	207

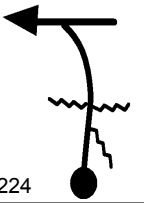
7.05	
V 35 01.24.21	
T65	208
7.32	
V 35 01.24.49	
T65	209
7.68	
V 35 01.25.26	
T65	210
8.18	
V 30 01.26.17	
T66	211
Acelere!	
8.22	
V 30 01.26.22	
T66	212
Atoleiro!!!!!!	
8.82	
V 30 01.27.34	
T66	213

8.98	
V 30 01.27.53 T66	214
9.06	
V 33 01.28.03 T67	215
9.39	
V 33 01.28.39 T67	216
9.52	
V 33 01.28.53 T67	217
9.63	
V 33 01.29.05 T67	218
9.88	
V 33 01.29.32 T67	219

10.04	
V 33 01.29.50	
T67	220
10.10	
V 33 01.29.56	
T67	221
10.26	
V 33 01.30.14	
T67	222
10.39	
N 1' 01.30.28	
T68	223
10.39	
V 35 01.31.28	
T69	224
10.54	
V 35 01.31.43	
T69	225

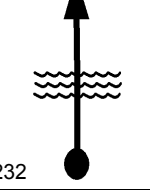
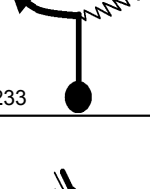
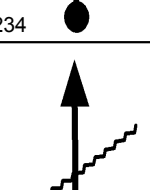
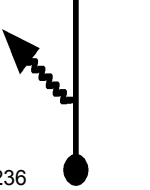
10.57	
V 35 01.31.46	
T69	226
10.70	
V 35 01.32.00	
T69	227
10.74	
0.00	
N 18' 01.32.04	
T70	228
Inicio 2ª Etapa	
0.00	
V 20 01.50.04	
T71	229
Cavalo velho!!	
0.03	
V 20 01.50.09	
T71	230

0.10	
V 33 01.50.22	231
T72	
0.44	
V 33 01.50.59	232
T72	
0.57	
V 33 01.51.13	233
T72	
0.68	
V 33 01.51.25	234
T72	
0.90	
V 33 01.51.49	235
T72	
0.92	
V 33 01.51.51	236
T72	

0.98	
V 33 01.51.58	
T72	237







1.07	
V 33 01.52.08	
T72	238



1.10	
V 33 01.52.11	
T72	239







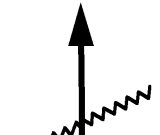
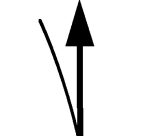
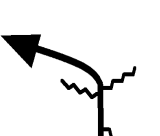
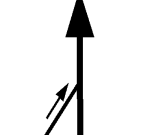
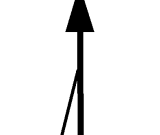

1.14	
V 33 01.52.15	
T72	240

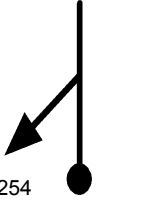
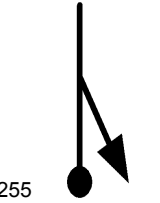
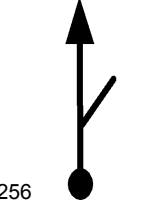
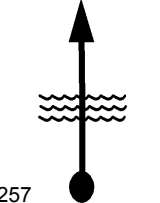
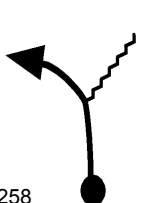
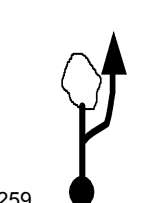

1.21	
V 33 01.52.23	
T72	241

1.27	
V 33 01.52.29 T72	242
1.36	
V 33 01.52.39 T72	243
1.51	
V 33 01.52.56 T72	244
1.70	
V 33 01.53.16 T72	245
1.94	
V 33 01.53.43 T72	246
2.07	
V 33 01.53.57 T72	247

2.30	
V 33 01.54.22 T72	248
2.32	
V 33 01.54.24 T72	249
2.49	
V 33 01.54.43 T72	250
2.66	
V 33 01.55.01 T72	251
2.71	
V 33 01.55.07 T72	252
2.82	
V 33 01.55.19 T72	253

2.96	
V 30 01.55.34	
T73	254
3.10	
V 30 01.55.51	
T73	255
3.45	
V 30 01.56.33	
T73	256
3.65	
V 30 01.56.57	
T73	257
3.67	
V 30 01.56.59	
T73	258
3.81	
V 30 01.57.16	
T73	259

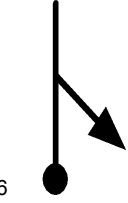
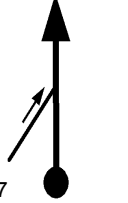
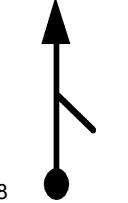
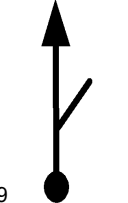
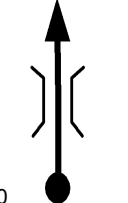
3.83	
V 30 01.57.18 T73	260
3.87	
V 30 01.57.23 T73	261
3.95	
V 30 01.57.33 T73	262
3.97	
V 30 01.57.35 T73	263
4.10	
V 30 01.57.51 T73	264
4.12	
V 30 01.57.53 T73	265

4.22	
V 30 01.58.05 T73	266
4.31	
V 30 01.58.16 T73	267
4.33	
V 30 01.58.18 T73	268
4.38	
V 30 01.58.24 T73	269
4.44	
V 30 01.58.31 T73	270
4.74	
N 4' 01.59.07 T74	271

Por Favor Respeite

a Propriedade!!!

4.74



V 12 02.03.07

T75

272

4.83



V 12 02.03.34

T75

273

4.92

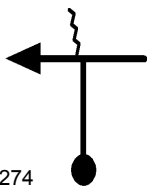

V 12 02.04.01

T75

274

4.94

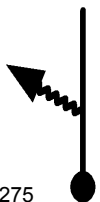

V 30 02.04.07

T76

275

5.02

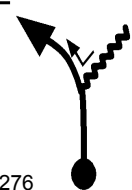

V 30 02.04.17

T76

276

5.36



V 30 02.04.58

T76

277

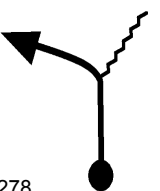
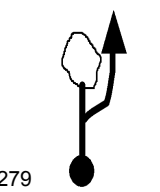
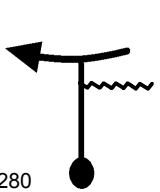
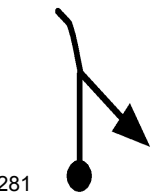
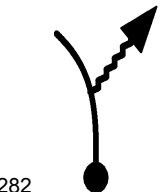
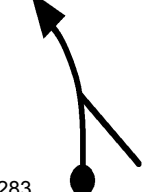
5.59	
V 30 02.05.25 T76	278
5.72	
V 30 02.05.41 T76	279
5.79	
V 30 02.05.49 T76	280
5.86	
V 30 02.05.58 T76	281
6.04	
V 30 02.06.19 T76	282
6.08	
V 30 02.06.24 T76	283

6.52	
V 30 02.07.17	
T76	284
6.57	
V 30 02.07.23	
T76	285
6.62	
V 30 02.07.29	
T76	286
Cuidado Trilha com pedras e degraus!!	
Risco de morte!!	
6.76	
V 15 02.07.46	
☠☠☠ T77	287
7.13	
V 27 02.09.15	
T78	288
7.33	
V 27 02.09.41	
T78	289

7.47	
V 27 02.10.00	
T78	290
7.68	
V 27 02.10.28	
T78	291
7.74	
N 2' 02.10.36	
T79	292
Bamp!!	
Respeite o Gado !!	
Gado arisco!!!!	
7.74	
V 15 02.12.36	
T80	293
Costear o Gravata	
7.94	
V 15 02.13.24	
T80	294

8.05	
V 15 02.13.50	
T80	295

Respeite os moradores!!

8.10	
V 15 02.14.02	
T80	296

8.16	
V 15 02.14.17	
T80	297

8.31	
V 35 02.14.53	
T81	298

9.23	
0.00	
V 35 02.16.27	
T82	299



2.32	
V 35 02.20.26	
T82	300

3.04

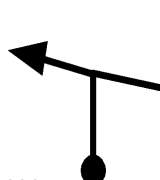

V 35 02.21.40
T82 301

3.35

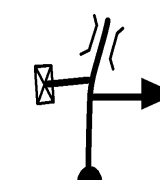

V 35 02.22.12
T82 302

5.02

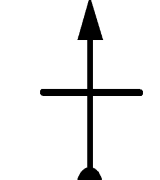

V 35 02.25.04
T82 303

5.57

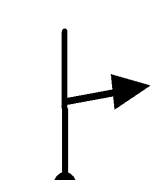

V 35 02.26.00
T82 304

Costear muro!!

6.53

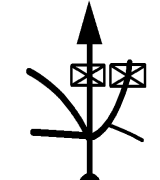

V 15 02.27.39
T83 305

6.62



V 15 02.28.01
T83 306

em direção ao mato

6.67



V 30 02.28.13

T84

307

6.80

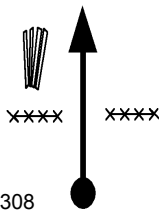

V 30 02.28.28

T85

308

7.02



V 30 02.28.55

T85

309

costear mato!!

7.40

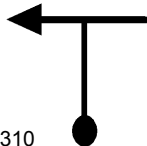

V 30 02.29.40

T85

310

7.45



V 30 02.29.46

T85

311



7.54







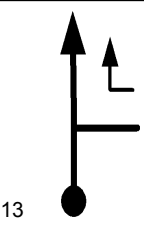

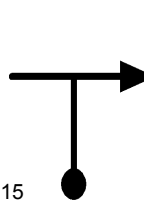
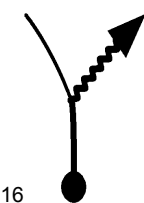
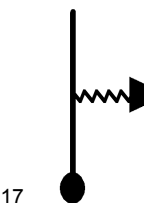
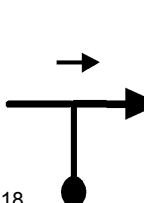
V 30 02.29.57

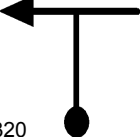
T85

312

7.64	
V 30 02.30.09 T85	
7.82	
N30s 02.30.31 T86	
7.82	
V 30 02.31.01 T87	
7.88	
V 30 02.31.08 T87	
8.14	
V 30 02.31.39 T87	
8.29	
V 30 02.31.57 T87	

8.47	
0.00	
N30s 02.32.19	
T88	319
0.00	
V 35 02.32.49	
 T89	320
0.23	
V 35 02.33.12	
T89	321
0.74	
V 25 02.34.05	
T90	322
0.87	
V 25 02.34.23	
T90	323
Bamp	
1.13	
V 30 02.35.01	
T91	324

Costear matol!!

1.30

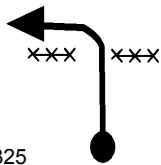

V 30 02.35.21

T91 325

Costear Mato!!

1.35

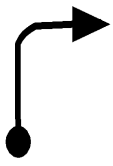

V 30 02.35.27

T91 326

costear mato..

1.44

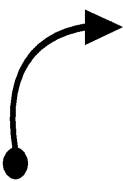

V 30 02.35.38

T91 327

1.60



V 30 02.35.57

T91 328

1.83



V 27 02.36.25

T92 329

2.19

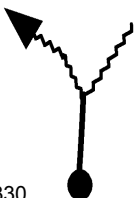

V 27 02.37.13

T92 330

Costear mato!!

2.29

V 33 02.37.26

T93 331



costear bananeira!!!

2.49

V 33 02.37.48

T93 332

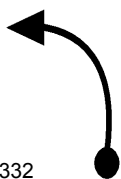

costear mato

2.87

V 33 02.38.29

T93 333

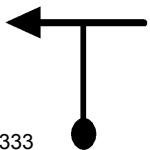

2.94

V 27 02.38.37

T94 334



3.28

V 30 02.39.22

T95 335

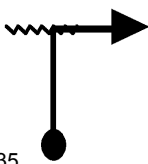

costear mato!!

3.52

V 30 02.39.51

T95 336

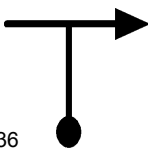

costear bananeira !!!

3.63

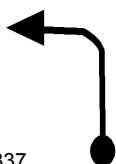

V 30 02.40.04

T95

337

3.72

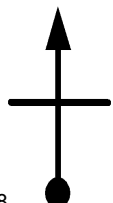

V 30 02.40.15

T95

338

3.76



V 30 02.40.20

T95

339

cuidado descida !!

3.96



V 21 02.40.44



T96

340

4.05



V 21 02.40.59

T96

341



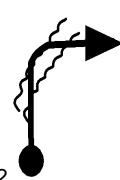

4.22





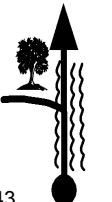

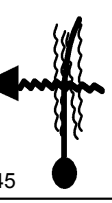
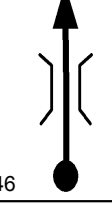
V 12 02.41.29

T97

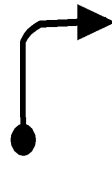
342

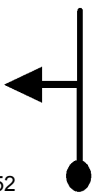
4.24	
V 12 02.41.35 T97	343
4.26	
V 12 02.41.41 T97	344
4.34	
V 12 02.42.05 T97	345
4.38	
V 12 02.42.17 T97	346
4.41	
V 12 02.42.26 T97	347
4.43	
V 12 02.42.32 T97	348

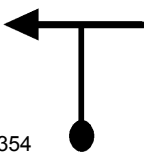
4.52	
V 12 02.42.59	
T97	349
4.63	
V 30 02.43.32	
T98	350
4.94	
N 3' 02.44.09	
T99	351
4.94	
V 27 02.47.09	
T100	352
no mato!!	
5.00	
V 27 02.47.17	
T100	353
5.33	
V 27 02.48.01	
T100	354

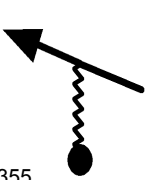
5.72	
V 27 02.48.53	
T100	355

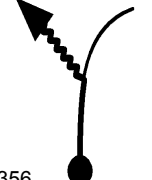

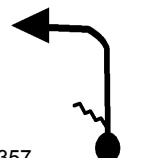
5.75	
V 27 02.48.57	
T100	356

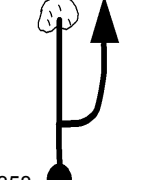

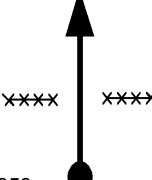

6.30	
V 27 02.50.10	
T100	357

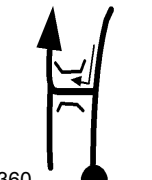
6.52	
V 27 02.50.39	
T100	358

6.59	
V 27 02.50.49	
T100	359

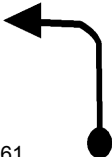
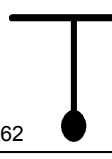

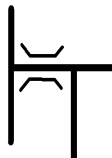
6.72	
V 33 02.51.06	
 T101	360

6.85	
V 33 02.51.20	361
7.02	
V 24 02.51.39	362
7.03	
V 24 02.51.40	363
7.40	
V 24 02.52.36	364
7.56	
V 24 02.53.00	365
7.83	
V 24 02.53.40	366
T102	

7.91

V 30 02.53.52

T103 367



7.94

V 30 02.53.56

T103 368



8.17

V 30 02.54.24

☠ T103 369



8.40

V 30 02.54.51

T103 370



Cuidado estrada geral!!

8.72

N30s 02.55.30

T104 371





8.72

V 30 02.56.00

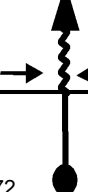
☠ T105 372

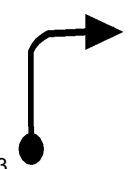

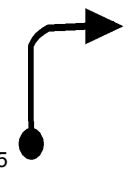
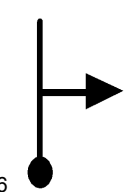
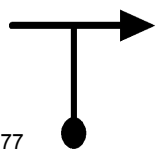
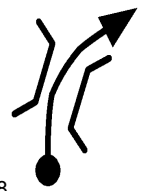
8.85	
V 30 02.56.15	T105 ³⁷³
Perigo de Morte!!	
ponte estreita !!!	
8.94	
V 30 02.56.26	T105 ³⁷⁴
☠☠☠	
9.19	
V 30 02.56.56	T105 ³⁷⁵
9.34	
V 30 02.57.14	T105 ³⁷⁶
9.83	
V 30 02.58.13	T106 ³⁷⁷
10.32	
V 35 02.59.12	T107 ³⁷⁸
☠☠	

10.68	
V 35 02.59.49	379
T107	
11.49	
V 35 03.01.12	380
T107	
13.13	
V 25 03.04.01	381
T108	
13.15	
V 25 03.04.03	382
T108	
13.26	
V 25 03.04.19	383
T108	
13.43	
V 25 03.04.44	384
T108	

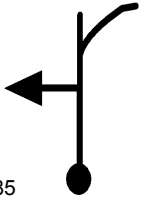
13.57	
V 25 03.05.04	
T108	385

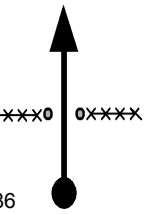
13.63	
V 25 03.05.13	
T108	386

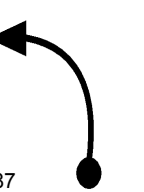
13.65	
V 25 03.05.15	
T108	387

Fim! Parabéns !!

Entregue seu colete!!

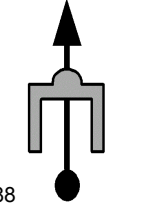
13.67	
V 25 03.05.18	
T108	388

FIM DE PROVA !!



www.t15.com.br

Tempo de Prova

MÉDIA C 03:05:18

FIM
