

INICIO

MÉDIA A

5º Enduro Amigos na Trilha
14/07/2018



IMPORTANTE

PLANILHA TERMICA
FITA ADESIVA DO LADO DE
TRÁS. NÃO USE CANETA
MARCA TEXTO,
USE CANETA ESFEROGRÁFICA
OU HIDROGRÁFICA

DIRETORES DE PROVA:
DIOGES OSELLAME
DIONATAN OSELLAME

REALIZAÇÃO:
EQUIPE AMIGOS NA TRILHA

NOS TRECHOS URBANOS
PREVALECEM AS LEIS DO
CÓDIGO NACIONAL DE
TRANSITO. É OBRIGAÇÃO
RESPEITAR AS PROPRIEDADES
ALHEIAS E OS MORADORES.
A ORGANIZAÇÃO NÃO SE
RESPONSABILIZA POR PASSAR
PROGRAMAÇÃO DE NAVEGAÇÃO.
É OBRIGAÇÃO DO PILOTO
CONFERIR A PROGRAMAÇÃO DO
NAVEGADOR.

LARGADA - 14:00 HS
CTG TIO MILLO
NEUTRO PRINCIPAL RANCHO DO CAVALO VELHO - SIDEROPOLIS
CHEGADA NO MESMO
LOCAL DA LARGADA

1 ETAPA KM 40,79
2 ETAPA KM 31,37
TOTAL KM 72,16

LEVANTAMENTO DA PROVA
COM MOTO CRF 230F COM
PNEU DIANTEIRO BOM
E 12 LIBRAS

☠️ CUIDADO
☠️☠️ ATENÇÃO
☠️☠️☠️ MUITA ATENÇÃO

Tempo de Prova

MÉDIA A 02:59:50



AFERIÇÃO

Aferição

0.00	
AFER	1
0.25	
AFER	2
0.36	
AFER	3
0.38	
AFER	4

0.64	
AFER	5

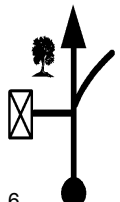
1.80	
AFER	6

Aferir!
Retorne com Cuidado!

2.269	
0.00	
AFER	7





INICIO DE PROVA

Inicio da Prova

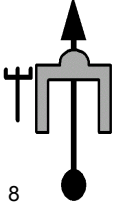
Boa Sorte !

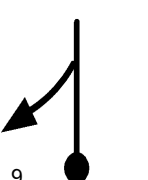
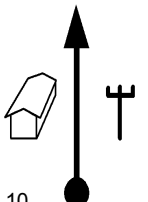
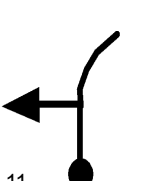
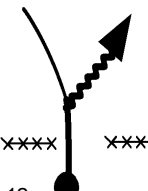
0.00	
V 25 00.00.00	
T1	8

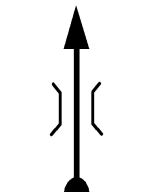
<p>0.25</p> <p>V 25 00.00.36</p> <p>T1</p>	 <p>9</p>
<p>0.42</p> <p>V 25 00.01.00</p> <p>T1</p>	 <p>10</p>
<p>0.56</p> <p>V 25 00.01.21</p> <p>T1</p>	 <p>11</p>
<p> siga bamp</p>	
<p>0.61</p> <p>V 36 00.01.28</p> <p>T2</p>	 <p>12</p>
<p> Bamp!</p>	
<p>0.65</p> <p>V 36 00.01.32</p> <p>T2</p>	 <p>13</p>
<p> ATENÇÃO!!</p>	
<p>0.77</p> <p>V 36 00.01.44</p> <p>T2</p>	 <p>14</p>

Bamp!

1.31

V 36 00.02.38

T2

15

Bamp!

1.50

V 36 00.02.57

T2

16

Bamp

1.54

V 36 00.03.01

T2

17

Cuidado Estrada Geral!

1.63

N 1' 00.03.10

T3

18

1.63

V 35 00.04.10

T4

19

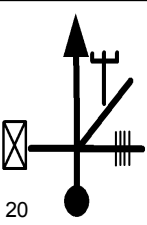
2.01	
V 35 00.04.49	20
T4	

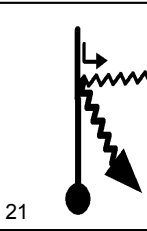
2.29	
V 39 00.05.18	21
T5	

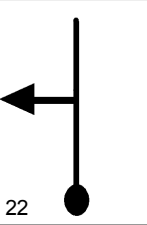

2.51	
V 39 00.05.38	22
T5	

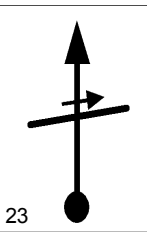
Atenção

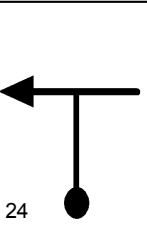
2.64	
V 39 00.05.50	23
T5	



2.75	
V 39 00.06.00	24
T5	

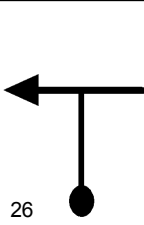

Cuidado! Estrada Geral!!!

2.96	
N 30s 00.06.20	25
 T6	

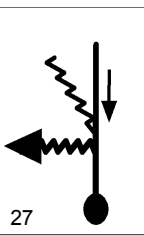

2.96	
V 39 00.06.50	
T7	26

moto contra

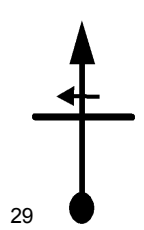

3.07	
V 39 00.07.00	
 T7	27

3.17	
V 39 00.07.09	
 T7	28

cuidado

3.33	
V 39 00.07.24	
 T7	29

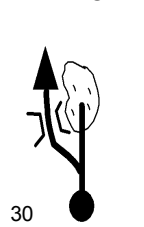
escolha o melhor lugar!







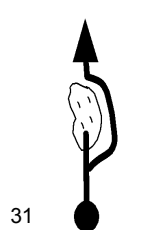

3.41	
V 27 00.07.31	
 T8	30



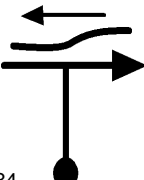

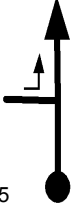
Atenção Pela Direita!!!

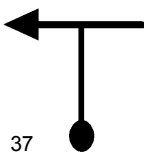



Se entrar no atoleiro

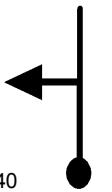
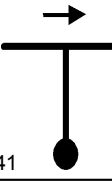



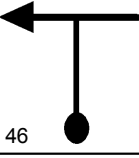
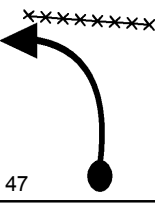

não sai mais!!!

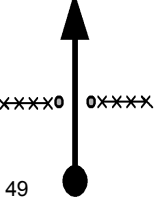
3.46	
V 27 00.07.38	
T8	31

3.48	
V 39 00.07.40	
T9	32
3.65	
V 39 00.07.56	
T9	33
3.86	
V 39 00.08.15	
 T9	34
4.04	
V 39 00.08.32	
T9	35
4.26	
N30s 00.08.52	
T10	36
4.26	
V 39 00.09.22	
 T11	37

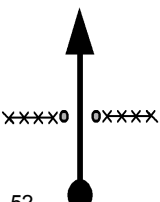
4.37	
V 39 00.09.33 T11	38
4.59	
V 39 00.09.53 T11	39
4.71	
V 39 00.10.04 T11	40
cuidado!	
4.79	
V 39 00.10.11 ☠☠☠ T11	41
4.84	
V 27 00.10.16 T12	42
4.89	
V 27 00.10.23 T12	43

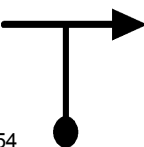
4.91	
V 39 00.10.25 T13	44
5.09	
V 39 00.10.42 T13	45
5.42	
V 39 00.11.12 T13	46
5.66	
V 39 00.11.35 T13	47
Bamp!	
5.81	
V 39 00.11.48 T13	48
6.03	
V 39 00.12.09 T13	49

6.43	
V 39 00.12.46	
T13	50
6.72	
V 50 00.13.12	
T14	51
6.74	
V 50 00.13.14	
T14	52
6.78	
V 50 00.13.17	
T14	53
6.84	
V 50 00.13.21	
T14	54
6.93	
V 36 00.13.27	
T15	55

7.00	
V 36 00.13.34	
T15	56

Bamp no eucalipto!

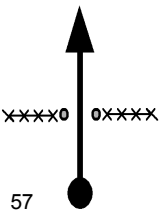
7.13	
V 36 00.13.47	
T15	57

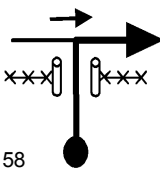
7.20	
V 39 00.13.54	
T16	58

7.36	
V 39 00.14.09	
T16	59

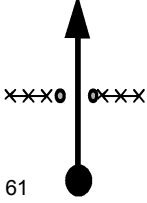

7.64	
V 50 00.14.35	
T17	60

7.66	
V 50 00.14.37	
T17	61

7.71	
V 50 00.14.40	
T17	62

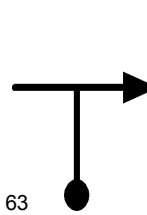
7.76	
V 50 00.14.44	
T17	63

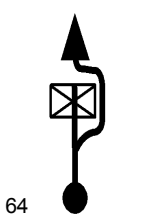
7.86	
V 36 00.14.51	
T18	64

Acelere!
subida com erosão !!!

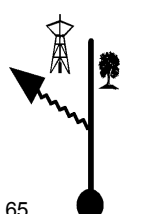
7.93	
V 36 00.14.58	
T18	65

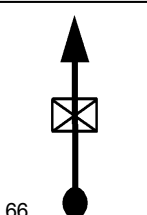
8.38	
V 36 00.15.43	
T18	66

8.43	
N 2' 00.15.48	
T19	67

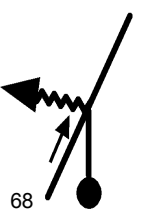
8.43	
V 33 00.17.48	
T20	68

8.52	
V 33 00.17.58	
T20	69

8.75	
V 33 00.18.23	
T20	70

Acelere!!

8.87	
V 33 00.18.36	
T20	71

Cuidado degrau!!!

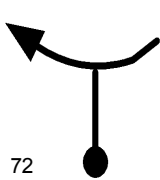
9.11	
V 35 00.19.02	
T21	72

9.28	
V 35 00.19.20	
T21	73

9.31	
V 39 00.19.23	
T22	74

Bamp





9.55	
V 39 00.19.45	
T22	75







Bamp

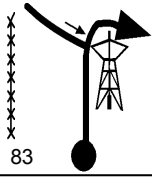
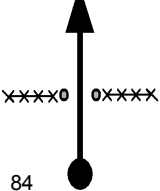

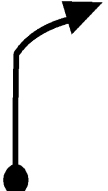
9.61	
V 39 00.19.50	
T22	76

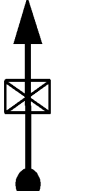
9.71	
V 39 00.20.00	
T22	77

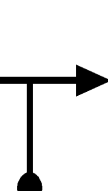
9.99	
V 36 00.20.25	
T23	78

10.06	
0.00	
V 36 00.20.32	
T24	79
0.04	
V 36 00.20.36	
T24	80
0.31	
V 36 00.21.03	
T24	81
Costear Mato!	
0.39	
V 36 00.21.11	
T24	82
0.61	
V 39 00.21.33	
T25	83
0.83	
V 39 00.21.54	
T25	84

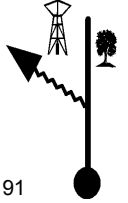
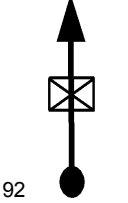
1.23	
V 39 00.22.31	
T25	85
1.51	
V 50 00.22.56	
T26	86
1.53	
V 50 00.22.58	
T26	87
1.57	
V 50 00.23.01	
T26	88
1.63	
V 50 00.23.05	
T26	89
1.73	
V 36 00.23.12	
T27	90

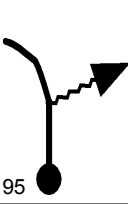
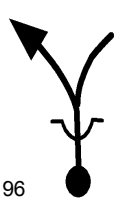
1.79	
V 36 00.23.18 T27	91
2.25	
V 36 00.24.04 T27	92
2.30	
N 2' 00.24.09 T28	93
2.30	
V 36 00.26.09 T29	94
2.56	
V 36 00.26.35 T29	95
Buraco	
2.73	
V 36 00.26.52 T29	96

costear mato

na direita

bamp

2.76

V 36 00.26.55

T29

97



2.80

V 36 00.26.59

T29

98



2.93

V 36 00.27.12

T29

99



2.99

V 36 00.27.18

T29

100



3.09

V 45 00.27.28

T30

101

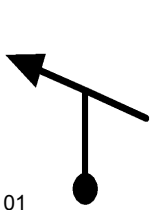



3.51

V 45 00.28.02

T30

102

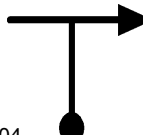

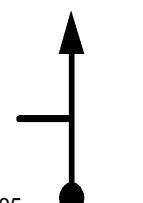
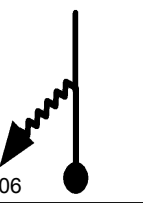
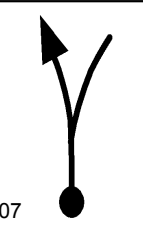
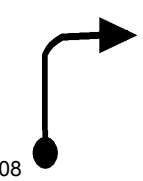
3.52	
N 1' 00.28.03	
T31	103
3.52	
V 35 00.29.03	
 T32	104
3.57	
V 35 00.29.08	
T32	105
3.81	
V 39 00.29.33	
T33	106
4.01	
V 39 00.29.51	
T33	107
4.59	
V 39 00.30.45	
T33	108

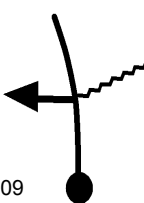
4.67	
V 33 00.30.52	
T34 109	

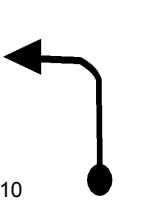
5.03	
V 33 00.31.31	
T34 110	

Escolha

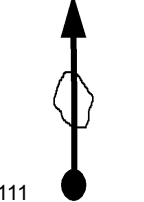

5.12	
V 33 00.31.41	
T34 111	

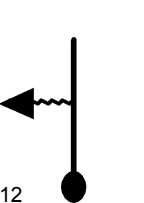
entrada escondida !!

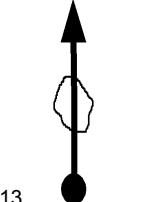
5.13	
V 30 00.31.42	
T35 112	

5.69	
V 30 00.32.49	
T35 113	

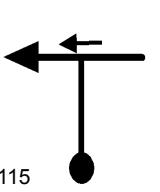
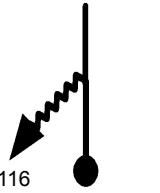
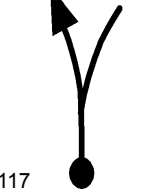
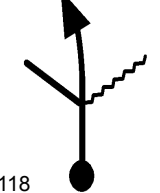
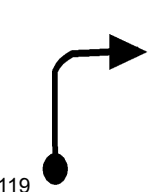
5.85	
NI'30s 00.33.09	
T36 114	

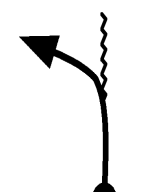
5.85	
V 39 00.34.39	115
T37	
6.09	
V 39 00.35.01	116
T37	
6.30	
V 39 00.35.20	117
T37	
6.97	
V 39 00.36.22	118
T37	
7.11	
V 39 00.36.35	119
T37	
	
7.17	
V 39 00.36.40	120
T37	

Entre no Mato!!!

7.20

V 39 00.36.43
T37

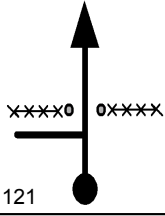

121

7.46

V 39 00.37.07
T37

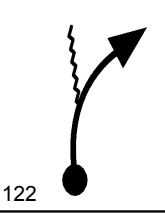

122

7.69

NI'30s 00.37.28
T38



123

7.69

V 35 00.38.58
T39

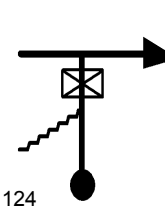

124

8.89

V 35 00.41.02
T39

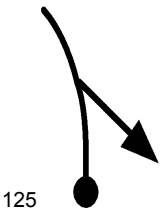

125

10.17

0.00

V 36 00.43.13
T40

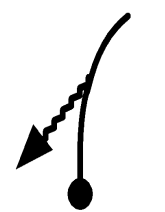

126

Descida com

Erosões!!!!

Cuidado!!

0.32

V 33 00.43.45

 T41

127

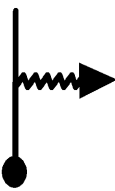

0.98

V 36 00.44.57

T42

128

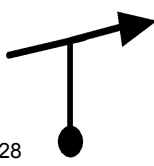

Não erre!!

Se entrar no

atoleiro nao sai mais!

1.26

V 27 00.45.25

T43

129

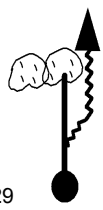

1.28

V 27 00.45.28

T43

130

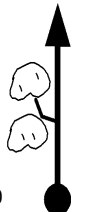

1.38

N 2' 00.45.41

T44

131



1.38
V 35 00.47.41
T45 132

Perigo ponte estreita !!!!!

2.65
V 35 00.49.52
T45 133

4.29
V 35 00.52.41
T45 134

Bamp

4.70
V 36 00.53.23
T46 135

4.88
V 36 00.53.41
T46 136

4.93
V 36 00.53.46
T46 137

4.99	
V 36 00.53.52	
T46	138

5.09	
V 36 00.54.02	
T46	139





trafego de caminhões



5.15	
V 33 00.54.08	
T47	140

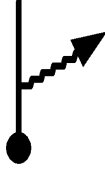

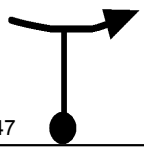

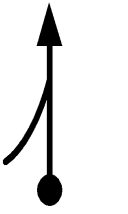
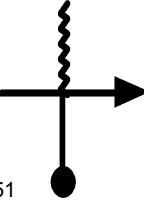
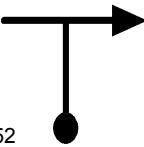
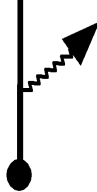
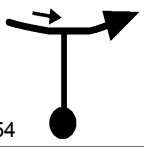

5.55	
V 33 00.54.52	
T47	141

5.60	
V 33 00.54.57	
T47	142

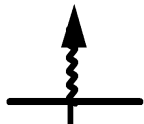
5.65	
V 33 00.55.02	
T47	143

5.71	
V 33 00.55.09	
T47	144
6.13	
V 33 00.55.55	
T47	145
6.15	
N 1' 00.55.57	
T48	146
6.15	
V 36 00.56.57	
T49	147
6.41	
V 36 00.57.23	
T49	148
6.62	
V 36 00.57.44	
T49	149

6.88	
V 36 00.58.10	
T49	150
6.97	
V 36 00.58.19	
T49	151
7.03	
V 20 00.58.25	
T50	152
7.36	
V 36 00.59.24	
T51	153
7.40	
V 36 00.59.28	
T51	154
7.66	
V 36 00.59.54	
T51	155

7.75	
V 36 01.00.03 T51	156
8.08	
N 2' 01.00.36 T52	157
8.08	
V 35 01.02.36 T53	158
8.15	
V 35 01.02.44 T53	159
8.96	
V 35 01.04.07 T53	160
9.39	
V 35 01.04.51 T53	161

9.67	
V 35 01.05.20	
T53	162
10.02	
0.00	
V 39 01.05.56	
T54	163
0.32	
V 39 01.06.25	
T54	164
0.41	
V 39 01.06.34	
T54	165
0.52	
V 39 01.06.44	
T54	166
0.56	
V 39 01.06.48	
T54	167

Erosões!!!!!!!

0.68

V 36 01.06.59

T55

168

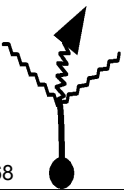

1.33

V 25 01.08.04

T56

169



Escolha o melhor lugar!!!

Perigo!!

1.36

V 25 01.08.08

T56

170



1.51

V 36 01.08.30

T57

171



1.90

V 36 01.09.09

T57

172



Bamp!

2.29

V 36 01.09.48

T57

173

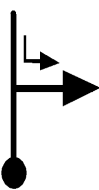

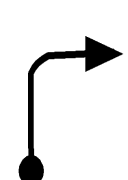

2.47	
V 36 01.10.06	
T57	174

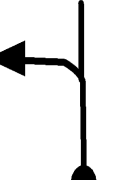
2.52	
V 36 01.10.11	
T57	175

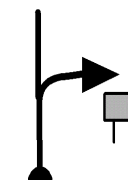
2.58	
V 36 01.10.17	
T57	176

2.68	
V 36 01.10.27	
T57	177

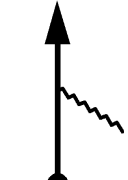
trafego de caminhões

2.74	
V 27 01.10.33	
 T58	178

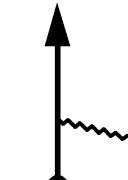
3.06	
V 27 01.11.15	
T58	179



liso!

Acelere

3.14

V 33 01.11.26

T59 180

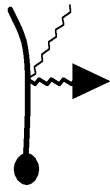

liso

3.25

V 33 01.11.38

 **T59** 181



3.39

V 36 01.11.53

T60 182

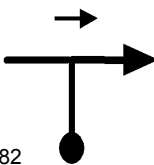







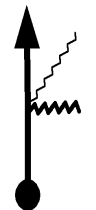

3.46



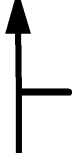

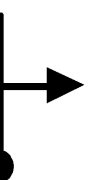
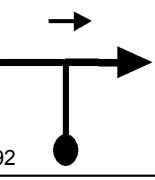
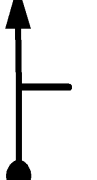

V 36 01.12.00



T60 183







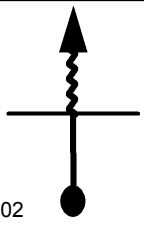

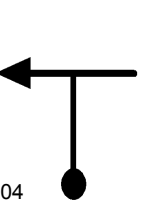
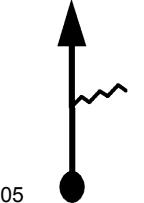
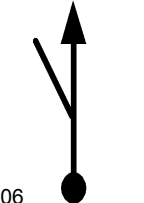
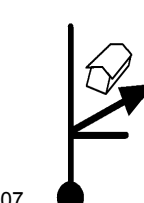

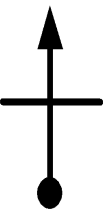

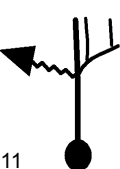
3.53	
V 36 01.12.07 T60	184
3.58	
V 36 01.12.12 T60	185
3.65	
V 36 01.12.19 T60	186
3.71	
V 36 01.12.25 T60	187
3.78	
V 36 01.12.32 T60	188
3.81	
V 36 01.12.35 T60	189



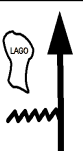

3.88	
V 36 01.12.42	190
T60	
3.94	
V 36 01.12.48	191
T60	
3.98	
V 36 01.12.52	192
T60	
4.05	
V 36 01.12.59	193
T60	
4.15	
V 36 01.13.09	194
T60	
4.46	
V 36 01.13.40	195
T60	

4.53	
N 2' 01.13.47  T61 196	
4.53	
V 35 01.15.47 T62 197	
4.58	
V 35 01.15.52 T62 198	
4.85	
V 36 01.16.20 T63 199	
5.05	
V 36 01.16.40 T63 200	
5.32	
V 36 01.17.07 T63 201	

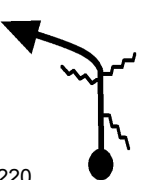
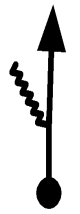

5.42	
V 36 01.17.17	
T63	202
5.73	
N 1' 01.17.48	
T64	203
5.73	
V 35 01.18.48	
T65	204
5.80	
V 35 01.18.55	
T65	205
6.36	
V 35 01.19.53	
T65	206
6.61	
V 35 01.20.19	
T65	207

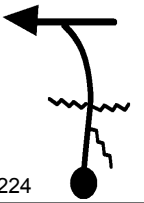
7.05	
V 35 01.21.04	
T65	208
7.32	
V 35 01.21.32	
T65	209
7.68	
V 35 01.22.09	
T65	210
8.18	
V 36 01.23.00	
T66	211
Acelere!	
8.22	
V 36 01.23.04	
T66	212
Atoleiro!!!!!!	
8.82	
V 36 01.24.04	
T66	213

8.98	
V 36 01.24.20	214
9.06	
V 39 01.24.28	215
9.39	
V 39 01.24.59	216
9.52	
V 39 01.25.11	217
9.63	
V 39 01.25.21	218
9.88	
V 39 01.25.44	219

10.04	
V 39 01.25.59	
T67	220
10.10	
V 39 01.26.04	
T67	221
10.26	
V 39 01.26.19	
T67	222
10.39	
N 2' 01.26.31	
T68	223
10.39	
V 35 01.28.31	
 T69	224
10.54	
V 35 01.28.46	
T69	225

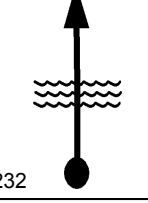
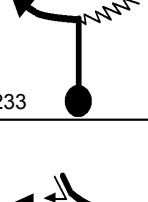
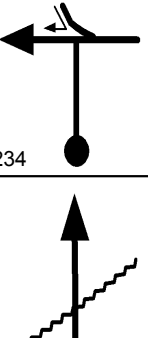
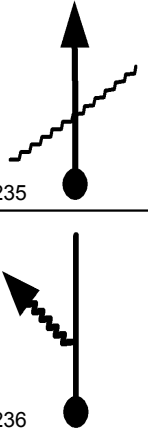
10.57	
V 35 01.28.49	
T69	226
10.70	
V 35 01.29.03	
T69	227
10.74	
0.00	
N 20' 01.29.07	
T70	228
Inicio 2ª Etapa	
0.00	
V 20 01.49.07	
T71	229
Cavalo velho!!	
0.03	
V 20 01.49.12	
T71	230

0.10	
V 39 01.49.25	231
T72	
0.44	
V 39 01.49.56	232
T72	
0.57	
V 39 01.50.08	233
T72	
0.68	
V 39 01.50.18	234
T72	
0.90	
V 39 01.50.39	235
T72	
0.92	
V 39 01.50.41	236
T72	

0.98	
V 39 01.50.46	
T72	237







1.07	
V 39 01.50.54	
T72	238



1.10	
V 39 01.50.57	
T72	239







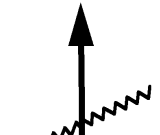
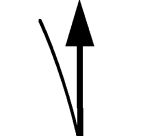
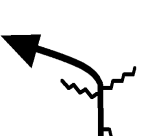
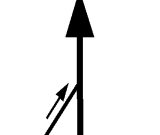
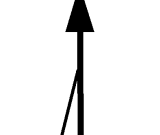

1.14	
V 39 01.51.01	
T72	240

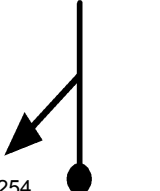
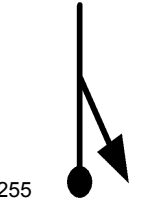
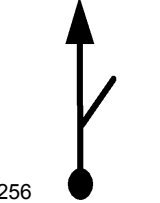
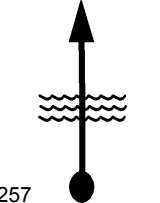
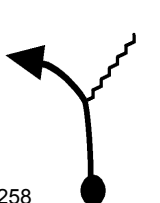
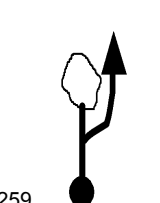

1.21	
V 39 01.51.07	
T72	241

1.27	
V 39 01.51.13	242
T72	
1.36	
V 39 01.51.21	243
T72	
1.51	
V 39 01.51.35	244
T72	
1.70	
V 39 01.51.53	245
T72	
1.94	
V 39 01.52.15	246
T72	
2.07	
V 39 01.52.27	247
T72	

2.30	
V 39 01.52.48 T72	248
2.32	
V 39 01.52.50 T72	249
2.49	
V 39 01.53.06 T72	250
2.66	
V 39 01.53.21 T72	251
2.71	
V 39 01.53.26 T72	252
2.82	
V 39 01.53.36 T72	253

2.96	
V 36 01.53.49	254
T73	
3.10	
V 36 01.54.03	255
T73	
3.45	
V 36 01.54.38	256
T73	
3.65	
V 36 01.54.58	257
T73	
3.67	
V 36 01.55.00	258
T73	
3.81	
V 36 01.55.14	259
T73	

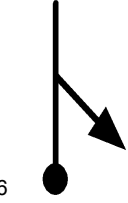
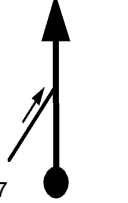
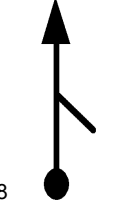
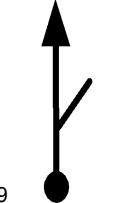
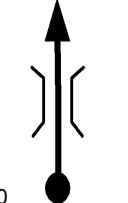
3.83	
V 36 01.55.16	260
T73	
3.87	
V 36 01.55.20	261
T73	
3.95	
V 36 01.55.28	262
T73	
3.97	
V 36 01.55.30	263
T73	
4.10	
V 36 01.55.43	264
T73	
4.12	
V 36 01.55.45	265
T73	

4.22	
V 36 01.55.55 T73	266
4.31	
V 36 01.56.04 T73	267
4.33	
V 36 01.56.06 T73	268
4.38	
V 36 01.56.11 T73	269
4.44	
V 36 01.56.17 T73	270
4.74	
N 4' 01.56.47 T74	271

Por Favor Respeite

a Propriedade!!!

4.74



V 12 02.00.47

T75

272

4.83



V 12 02.01.14

T75

273

4.92

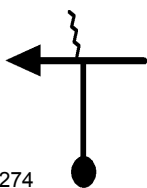

V 12 02.01.41

T75

274

4.94

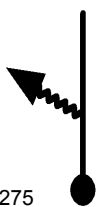

V 36 02.01.47

T76

275

5.02

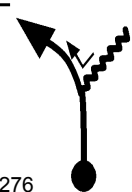

V 36 02.01.55

T76

276



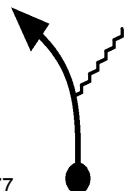



5.36

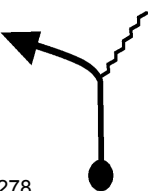

V 36 02.02.29

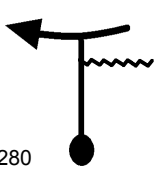
T76

277

5.59	
V 36 02.02.52 T76	278
5.72	
V 36 02.03.05 T76	279
5.79	
V 36 02.03.12 T76	280
5.86	
V 36 02.03.19 T76	281
6.04	
V 36 02.03.37 T76	282
6.08	
V 36 02.03.41 T76	283

6.52	
V 36 02.04.25	
T76	284
6.57	
V 36 02.04.30	
T76	285
6.62	
V 36 02.04.35	
T76	286
Cuidado Trilha com pedras e degraus!!	
Risco de morte!!	
6.76	
V 21 02.04.49	
☠☠☠ T77	287
7.13	
V 33 02.05.52	
T78	288
7.33	
V 33 02.06.14	
T78	289

7.47	
V 33 02.06.29	
T78	290
7.68	
V 33 02.06.52	
T78	291
7.74	
N 2' 02.06.59	
T79	292
Bamp!!	
Respeite o Gado !!	
Gado arisco!!!!	
7.74	
V 15 02.08.59	
T80	293
Costear o Gravata	
7.94	
V 15 02.09.47	
T80	294

8.05	
V 15 02.10.13 T80	295

Respeite os moradores!!

8.10	
V 15 02.10.25 T80	296

8.16	
V 15 02.10.40 T80	297

8.31	
V 35 02.11.16 T81	298

9.23	
0.00 V 35 02.12.50 T82	299

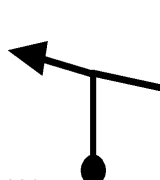

2.32	
V 35 02.16.49 T82	300

3.04	
V 35 02.18.03	
T82	301

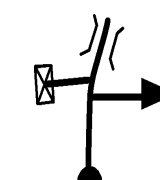
3.35	
V 35 02.18.35	
T82	302

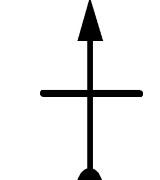
5.02	
V 35 02.21.27	
T82	303

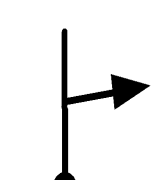
5.57	
V 35 02.22.23	
T82	304

Costear muro!!

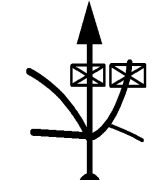
6.53	
V 15 02.24.02	
T83	305

6.62	
V 15 02.24.24	
T83	306

em direção ao mato

6.67



V 30 02.24.36

T84

307

6.80

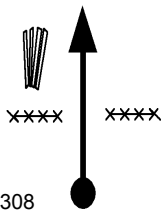

V 36 02.24.51

T85

308

7.02



V 36 02.25.13

T85

309

costear mato!!

7.40

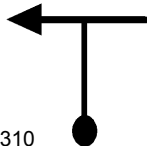

V 36 02.25.51

T85

310

7.45



V 36 02.25.56

T85

311

7.54







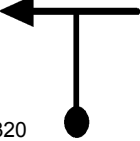

V 36 02.26.05

T85

312

7.64	
V 36 02.26.15 T85	
7.82	
N 1' 02.26.33 T86	
7.82	
V 36 02.27.33 T87	
7.88	
V 36 02.27.39 T87	
8.14	
V 36 02.28.05 T87	
8.29	
V 36 02.28.20 T87	

8.47	
0.00	
N 1' 02.28.38	
T88	319
0.00	
V 35 02.29.38	
 T89	320
0.23	
V 35 02.30.02	
T89	321
0.74	
V 25 02.30.54	
T90	322
0.87	
V 25 02.31.13	
T90	323
Bamp	
1.13	
V 36 02.31.50	
T91	324

Costear matol!!

1.30

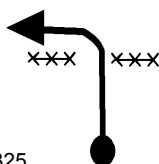

V 36 02.32.07

T91 325

Costear Mato!!

1.35



V 36 02.32.12

T91 326

costear mato..

1.44

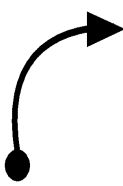

V 36 02.32.21

T91 327

1.60



V 36 02.32.37

T91 328

1.83



V 33 02.33.00

T92 329

2.19

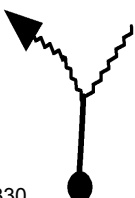

V 33 02.33.40

T92 330

Costear mato!!

2.29

V 39 02.33.51

T93 331



costear bananeira!!!

2.49

V 39 02.34.09

T93 332

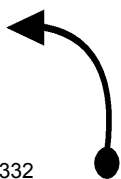

costear mato

2.87

V 39 02.34.44

T93 333

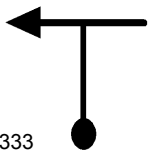

2.94

V 33 02.34.51

T94 334



3.28

V 36 02.35.28

T95 335

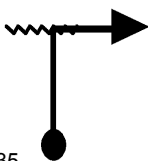

costear mato!!

3.52

V 36 02.35.52

T95 336

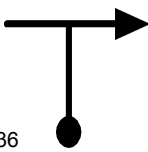

costear bananeira !!!

3.63

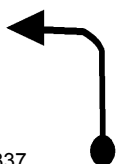

V 36 02.36.03

T95

337

3.72

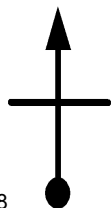

V 36 02.36.12

T95

338

3.76



V 36 02.36.16

T95

339

cuidado descidaõ !!

3.96



V 27 02.36.36

☠☠☠ T96

340

4.05



V 27 02.36.48

T96

341



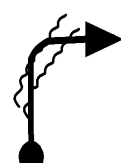

4.22





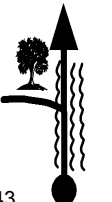

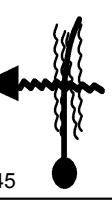
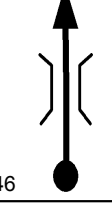
V 18 02.37.10

T97

342

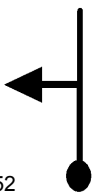
4.24	
V 18 02.37.14 T97	343
4.26	
V 18 02.37.18 T97	344
4.34	
V 18 02.37.34 T97	345
4.38	
V 18 02.37.42 T97	346
4.41	
V 18 02.37.48 T97	347
4.43	
V 18 02.37.52 T97	348

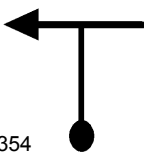
4.52	
V 18 02.38.10	
T97	349
4.63	
V 36 02.38.32	
T98	350
4.94	
N 4' 02.39.03	
T99	351
4.94	
V 33 02.43.03	
T100	352
no mato!!	
5.00	
V 33 02.43.10	
T100	353
5.33	
V 33 02.43.46	
T100	354

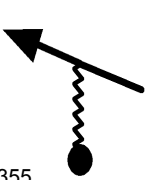
5.72	
V 33 02.44.28	
T100	355

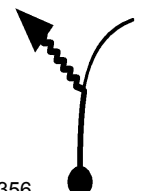

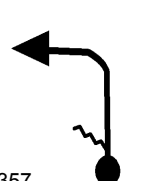
5.75	
V 33 02.44.32	
T100	356

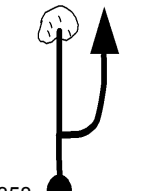
6.30	
V 33 02.45.32	
T100	357

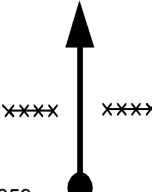

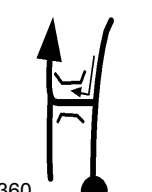

6.52	
V 33 02.45.56	
T100	358

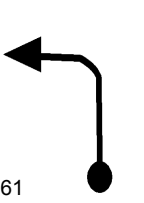
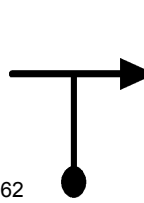
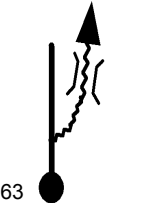
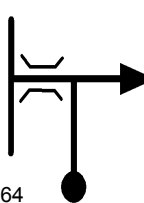
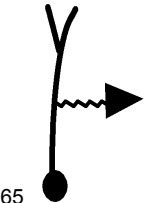
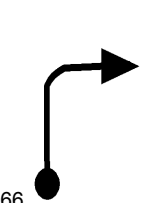

6.59	
V 33 02.46.03	
T100	359

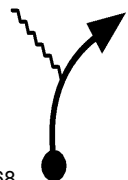

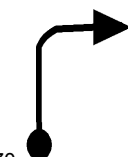
6.72	
V 39 02.46.18	
 T101	360

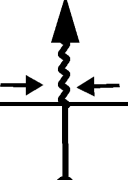
6.85	
V 39 02.46.30	
T101	361
7.02	
V 30 02.46.45	
T102	362
7.03	
V 30 02.46.46	
T102	363
7.40	
V 30 02.47.31	
T102	364
7.56	
V 30 02.47.50	
T102	365
7.83	
V 30 02.48.22	
T102	366

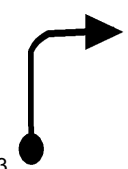
7.91	
V 36 02.48.32	367
T103	
7.94	
V 36 02.48.35	368
T103	
8.17	
V 36 02.48.58	369
T103	
8.40	
V 36 02.49.21	370
T103	
Cuidado estrada geral!!	
8.72	
N 1' 02.49.53	371
T104	
8.72	
V 36 02.50.53	372
T105	

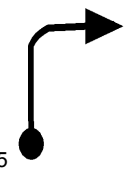
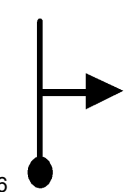
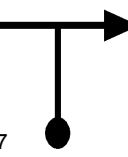
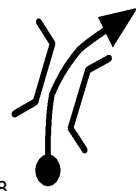
8.85	
V 36 02.51.06	T105 373
Perigo de Morte!!	
ponte estreita !!!	
8.94	
V 36 02.51.15	T105 374
☠☠☠	
9.19	
V 36 02.51.40	T105 375
9.34	
V 36 02.51.55	T105 376
9.83	
V 30 02.52.44	T106 377
10.32	
V 35 02.53.43	T107 378
☠☠☠	

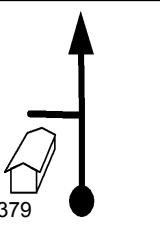
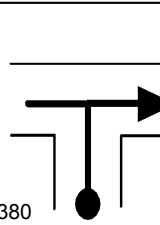
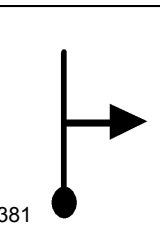
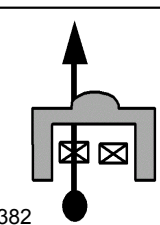
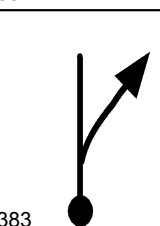
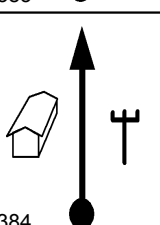
10.68	
V 35 02.54.20	379
T107	
11.49	
V 35 02.55.43	380
T107	
13.13	
V 25 02.58.32	381
T108	
13.15	
V 25 02.58.35	382
T108	
13.26	
V 25 02.58.51	383
T108	
13.43	
V 25 02.59.15	384
T108	

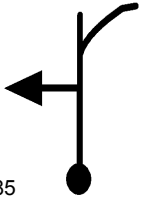
13.57	
V 25 02.59.35	
T108 ³⁸⁵	

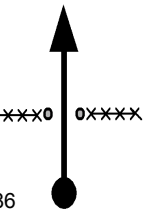
13.63	
V 25 02.59.44	
T108 ³⁸⁶	

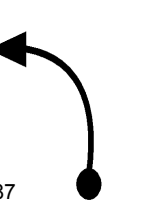
13.65	
V 25 02.59.47	
T108 ³⁸⁷	

Fim! Parabéns !!

Entregue seu colete!!

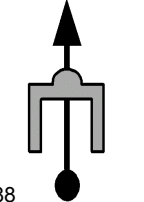
13.67	
V 25 02.59.50	
T108 ³⁸⁸	

FIM DE PROVA !!



www.t15.com.br

Tempo de Prova

MÉDIA A 02:59:50

FIM
