



# INICIO

## MÉDIA C







6 ENDURO AMIGOS NA TRILHA  
01 e 02 de Janeiro / 2015



## IMPORTANTE

PLANILHA TERMICA  
FITA ADESIVA DO LADO DE  
TRÁS. NÃO USE CANETA  
MARCA TEXTO,  
USE CANETA ESFEROGRÁFICA  
OU HIDROGRÁFICA

-----  
DIRETORES DE PROVA:  
DIOGES OSELLAME  
CLEBSON OSELLAME  
REALIZAÇÃO: AMIGOS NA TRILHA  
NOS TRECHOS URBANOS  
PREVALECEM AS LEIS  
DO CÓDIGO NACIONAL  
DETRANSPITO. É OBRIGAÇÃO  
RESPEITAR AS  
PROPRIEDADES  
ALHEIAS E OS MORADORES.  
A ORGANIZAÇÃO NÃO SE  
RESPONSABILIZA POR PASSAR  
PROGRAMAÇÃO DE NAVEGAÇÃO.  
É OBRIGAÇÃO DO PILOTO  
CONFERIR A PROGRAMAÇÃO DO  
NAVEGADOR.  
LARGADA - 14:00 HS  
CTG TIO MILLO  
NEUTRO PRINCIPAL  
LOCAL DA LARGADA  
CHEGADA NO MESMO  
LOCAL DA LARGADA  
1 ETAPA KM  
2 ETAPA KM  
TOTAL KM  
LEVANTAMENTO DA PROVA  
COM MOTO CRF 230 COM  
PNEU DIANTEIRO NOVO  
E 12 LIBRAS

 **CUIDADO**  
  **ATENÇÃO**  
   **MUITA ATENÇÃO**





**Tempo de Prova**



MÉDIA C 03:00:02







**AFERIÇÃO**

AFERIR

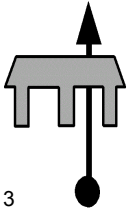
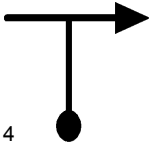
0.00	
<b>AFER</b>	1 

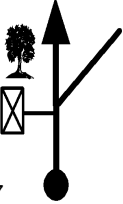
0.24	
<b>AFER</b>	2 

0.35	
AFER	3
0.37	
AFER	4
LOMBADA	
0.63	
AFER	5
1.46	
AFER	6
1.76	
AFER	7
AFERIR!!	
2.220	
<b>0.00</b>	
AFER	8



**INICIO DE PROVA**

BOA SORTE!!

0.00 V 25 00.00.00 T1	
0.24 V 25 T1	
0.41 V 25 T1	
0.54 V 25 T1	
0.58 V 21 00.01.24 T2	

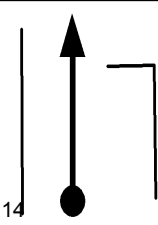
0.74	
V 21	
T2	14

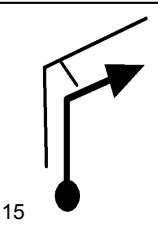
0.76	
V 21	
T2	15

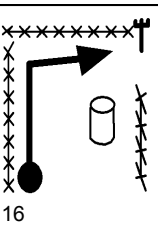
0.78	
V 21	
T2	16

por baixo da casinha

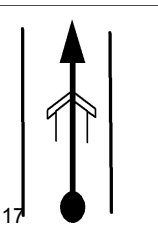
0.91	
V 21	
T2	17

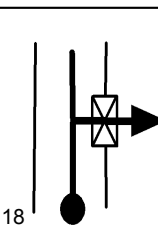
0.94	
V 21	
T2	18

costear cerca

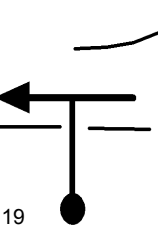
0.95	
V 15 00.02.27	
T3	19

0.99	
V 15	20
T3	
bamp	
1.01	
V 15	21
T3	
1.03	
V 30 00.02.46	22
T4	
1.05	
V 30	23
T4	
PONTE!!	
PERIGO!	
1.14	
V 30	24
☠ T4	
BAMP	
1.58	
V 30	25
T4	

COSTEAR MATO!!

1.67

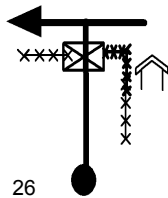

V 30

T4

26

COSTEAR MATO!!

1.85

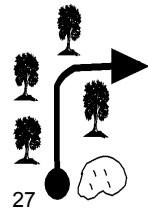

V 30

T4

27

COSTEAR MATO!!

1.96

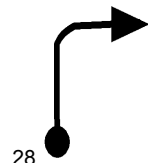

V 30

T4

28

2.20



V 30

T4

29

BAMP

2.24



V 30

T4

30



BAMP

2.26

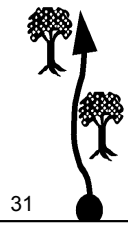

V 30

T4

2.31

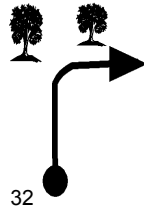

V 27 00.05.20

T5

VALO

2.34

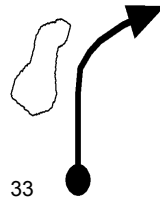

V 27

T5

VALO

2.37



V 27

T5

VALO

2.39

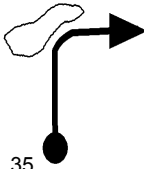

V 27

T5

2.43	
V 27	
T5	36
2.52	
N 1' 00.05.48	
T6	37
2.52	
0.00	
V 20 00.06.48	
T7	38
0.04	
V 20	
T7	39
0.13	
V 20	
T7	40
0.18	
V 20	
T7	41

<h1>0.20</h1>	
<b>V 30</b>	<b>00.07.24</b>
<b>T8</b>	42

COSTEAR CERCA

<h1>0.36</h1>	
<b>V 30</b>	<b>00.07.24</b>
<b>T8</b>	43

COSTEAR CERCA

<h1>0.72</h1>	
<b>V 30</b>	<b>00.07.24</b>
<b>T8</b>	44

<h1>0.83</h1>	
<b>V 30</b>	<b>00.07.24</b>
<b>T8</b>	45

<h1>1.16</h1>	
<b>V 30</b>	<b>00.07.24</b>
<b>T8</b>	46

COSTEAR CERCA

<h1>1.26</h1>	
<b>V 30</b>	<b>00.07.24</b>
<b>T8</b>	47

1.61	
V 27 00.10.13	
T9	48
PELO	
TRILHO	
DO	
GADO!!	
1.64	
V 27	
T9	49
1.68	
V 27	
T9	50
BAMP	
1.70	
V 27	
T9	51
DENTRO DO RIO	
BAMP	
1.74	
V 33 00.10.30	
T10	52

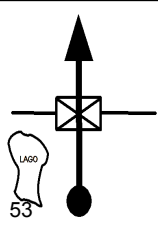
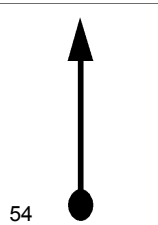
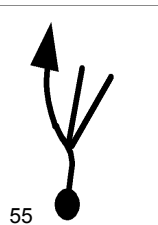
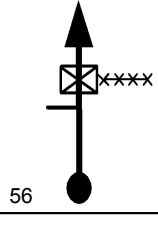
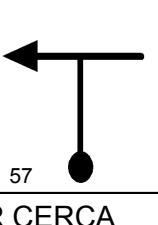
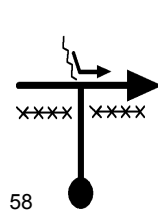
1.80	
V 33	
T10	53
BAMP	
1.96	
V 33	
T10	54
ENTRE NO MATO	
2.06	
V 27 00.11.05	
T11	55
2.12	
V 27	
T11	56
2.16	
V 27	
T11	57
COSTEAR CERCA	
2.31	
V 30 00.11.38	
T12	58

2.46

V 30

T12

59

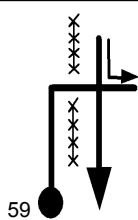

BAMP

2.52

V 30

T12

60



BAMP

2.58

V 30

T12

61

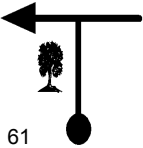

2.61

V 30

T12

62

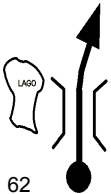

COSTEAR CERCA



2.65

V 30

T12

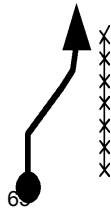
63

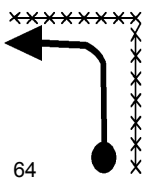
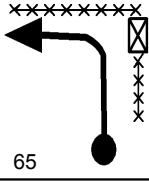

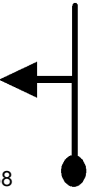
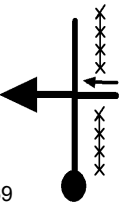
2.71	
V 30	
T12	64
COSTEAR CERCA	
2.73	
V 30	
T12	65
2.83	
NI'30s 00.12.41	
T13	66
2.83	
V 27 00.14.11	
T14	67
2.89	
V 27	
T14	68
2.90	
V 27	
T14	69

NAO ERRE

2.95



V 27



T14

70

3.01

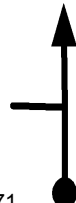

V 30 00.14.35

T15

71

3.09

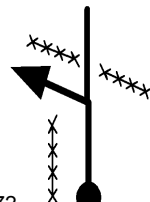

V 30

T15

72

BAMP

3.16

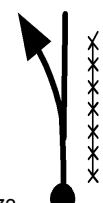

V 30

T15

73

COSTEAR CERCA

3.26

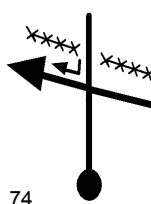

V 30

T15

74

3.43

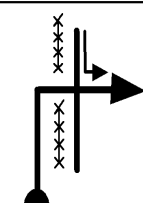

V 27 00.15.25

T16

75



NAO ERRE

3.49

V 27

T16



76

3.54

V 30 00.15.40

T17



77

COSTEAR CERCA

3.63

V 30

T17

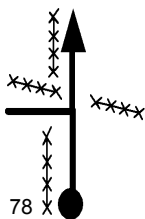

78

COSTEAR CERCA

3.69

V 30

T17

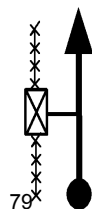

79

COSTEAR CALIPO

DA ESQUERDA

3.78

V 30

T17

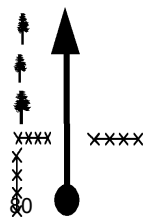

80

ATENÇÃO

3.92

V 30



T17

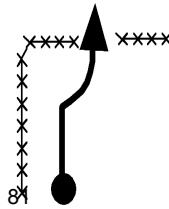

COESTEAR EUCALIPTO

4.06

V 30

T17

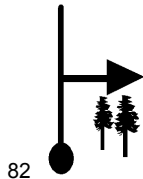

CUIDADO CEPO

4.11

V 24 00.16.48

T18

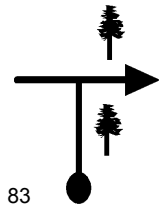

BAMP

4.18

V 24

T18



BAMP

4.25

V 24

T18

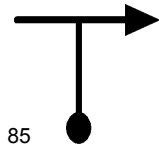

BAMP

4.30

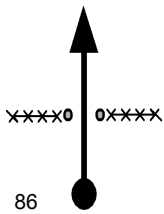

V 24

T18

86

4.34

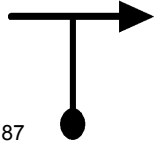

V 24

T18

87

4.37

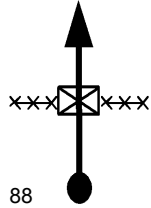

V 24

T18

88

4.38



V 24

T18

89

4.47

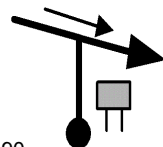

V 30 00.17.42

T19

90

PERIGO!!

4.54

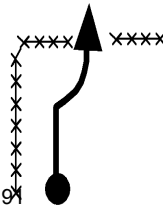

V 30

T19

91



BAMP

4.68

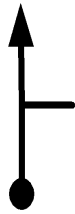

V 21 00.18.08

T20 92

4.73



V 21

T20 93

4.79



V 21

T20 94

4.92

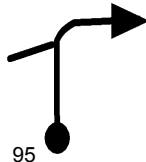

V 33 00.18.49

T21 95

5.06



V 33





T21 96



5.18

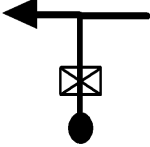
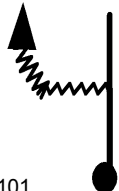
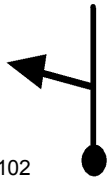
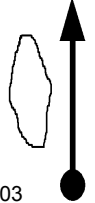

V 33

T21 97

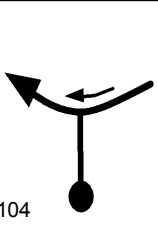
5.30	
V 33	
T21	98
5.61	
N 2' 00.20.04	
T22	99
5.61	
0.00	
V 30 00.22.04	
T23	100
0.12	
V 27 00.22.18	
T24	101
0.29	
V 27	
T24	102
BURACO	
PELA DIREITA	
0.31	
V 27	
 T24	103

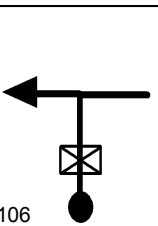
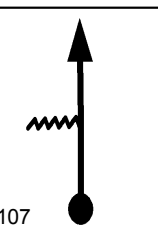
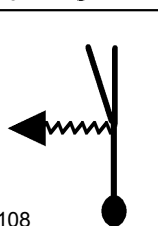
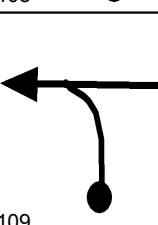
0.35	
V 33 00.22.49	
T25	104
0.66	
N 1' 00.23.23	
T26	105
0.66	
V 30 00.24.23	
T27	106
0.78	
V 30	
T27	107
1.08	
V 27 00.25.13	
T28	108
1.31	
V 27	
T28	109

POSTE TBG

1.34	
V 27	
T28	110

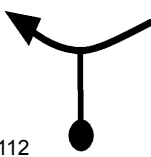

1.58	
V 27	
T28	111

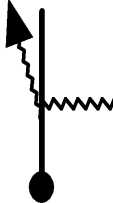
1.76	
V 30 00.26.44	
T29	112

2.01	
V 39 00.27.14	
T30	113

2.05	
V 39	
T30	114

EROSÕES

2.27	
V 27 00.27.38	
 T31	115

2.51	
V 30 00.28.10	
T32	116

BAMP

2.64	
V 30	
T32	117

2.71	
V 30	
T32	118

2.82	
V 30	
T32	119



2.87	
V 33 00.28.53	
T33	120



3.14	
V 33	
T33 121	

3.16	
V 33	
T33 122	

3.21	
V 33	
T33 123	

3.26	
V 33	
T33 124	

EROSÕES

3.36	
V 30 00.29.47	
T34	
T34 125	

3.42	
V 30	
T34 126	

BAMP

3.54

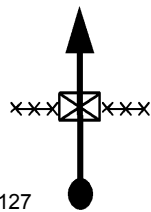

V 30

T34 127

3.63

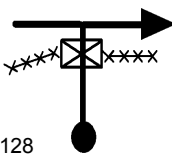

V 30

T34 128

3.77

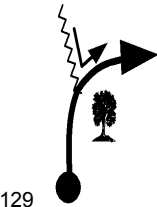

V 33 00.30.36

T35 129

4.04



V 33

T35 130

COSTEAR CERCA

4.25



V 27 00.31.28

T36 131

BAMP

4.43

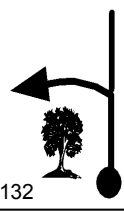

V 30 00.31.52

T37 132

4.52

V 30

T37 133

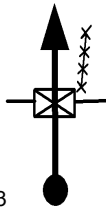

4.63

V 30

T37 134



4.77

V 30

T37 135



4.99

V 30

T37 136



COSTEAR CERCA

5.04

V 30

T37 137

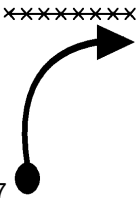





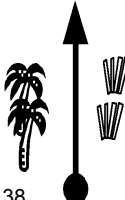

BAMP

5.10

V 21 00.33.13

T38 138

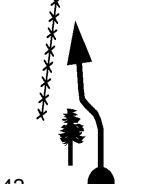
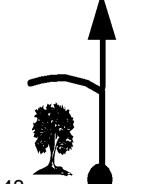

5.20	
NI'30s 00.33.30	
<b>T39</b>	139
ATENÇÃO	
5.20	
V 33 00.35.00	
<b>T40</b>	140
5.47	
V 33	
<b>T40</b>	141
5.68	
V 30 00.35.52	
<b>T41</b>	142
5.86	
V 30	
<b>T41</b>	143
5.90	
N 1' 00.36.18	
<b>T42</b>	144

5.90	
V 27 00.37.18	
<b>T43</b>	145
6.13	
<b>0.00</b>	
V 30 00.37.49	
<b>T44</b>	146
0.15	
V 30	
<b>T44</b>	147
0.26	
V 33 00.38.20	
<b>T45</b>	148
0.36	
V 33	
<b>T45</b>	149
0.51	
V 33	
<b>T45</b>	150

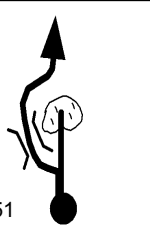
0.60	
V 21 00.38.57	
T46	151

0.63	
V 21	
T46	152

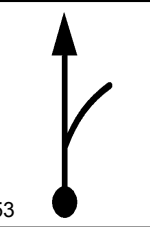

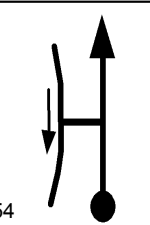
0.66	
V 33 00.39.08	
T47	153



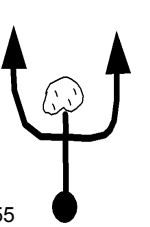

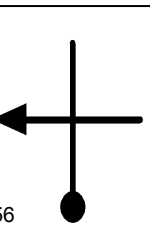
0.82	
V 33	
T47	154

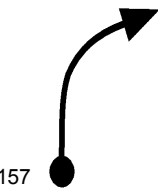
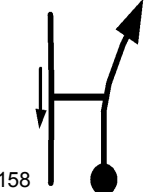
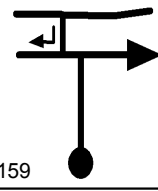
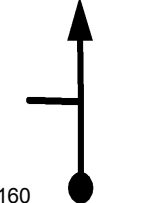
ESCOLHA!

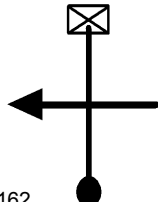
0.93	
V 27 00.39.37	
T48	155

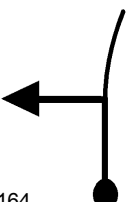
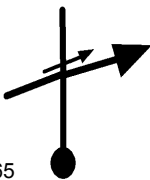
0.96	
V 33 00.39.41	
T49	156

1.25	
V 33	
T49	157
ATENÇÃO!!	
1.29	
V 33	
T49	158
ATENÇÃO!!	
1.48	
V 33	
T49	159
1.66	
V 33	
T49	160
1.89	
NI'30s 00.41.23	
T50	161
1.89	
V 30 00.42.53	
T51	162

2.00	
V 30 00.43.06	
T52	163
2.20	
V 30	
T52	164
ATENÇÃO	
2.35	
V 33 00.43.48	
 T53	165
2.43	
V 21 00.43.56	
T54	166
2.46	
V 21	
T54	167
2.50	
V 33 00.44.08	
T55	168

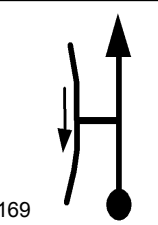

2.67	
V 33	
T55	169

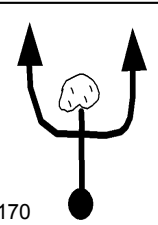
2.78	
V 27 00.44.39	
T56	170

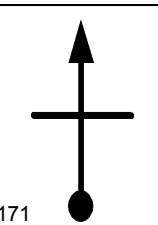
2.81	
V 30 00.44.43	
T57	171

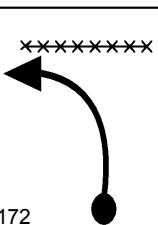
3.04	
V 30	
T57	172

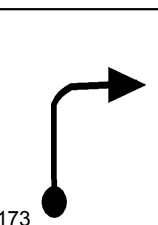
3.15	
V 30	
T57	173

COSTEAR CERCA

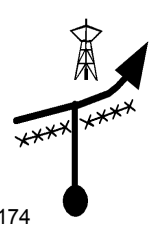
3.20	
V 33 00.45.30	
T58	174

COSTEAR MATO

3.25

V 33

T58 175

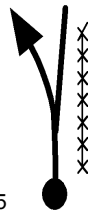

3.43

V 27 00.45.55

T59 176



3.50

V 27

T59 177

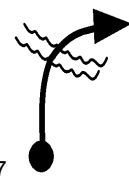

ACELERE!!

3.64

V 27

T59 178

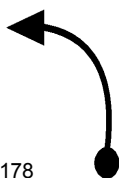

BAMP

3.72

V 24 00.46.34

T60 179



3.84

N 2' 00.46.52

T61 180



NÃO ERRE

3.84

V 33 00.48.52

T62

181



4.03

V 33

T62

182



4.16

V 21 00.49.26

T63

183



NAO ERRE!

POSTE TBG

4.27

V 30 00.49.45



T64

184



4.50

V 30

T64

185

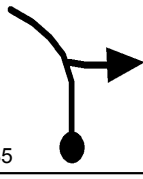

4.54

V 30

T64

186

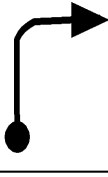

ENTRE NO

CALIPAL

4.57

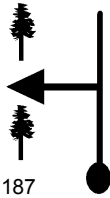

V 30

T64

187

4.77

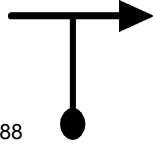

V 30 00.50.45

T65

188

4.80



V 30

T65

189

4.83

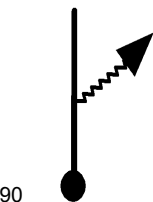

V 30 00.50.52

T66

190

4.99

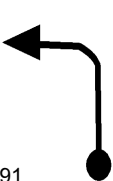

V 30

T66

191

5.09

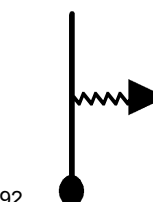

V 27 00.51.24

T67

192

ATOLEIRO!

5.64

V 27

T67

193



5.79

N 1' 00.52.57

T68

194



5.79

0.00

V 30 00.53.57

T69

195

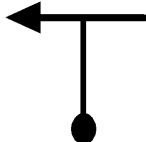

0.23

V 30

T69

196



0.32

V 30

T69

197

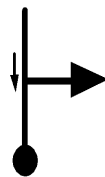

0.64

V 30 00.55.14

T70

198



CUIDADO ESTRADA!

0.79

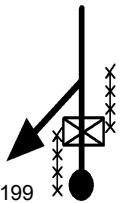

V 36 00.55.32



T71

199

1.29

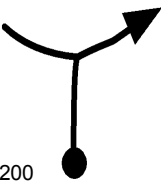

V 36

T71

200

2.00

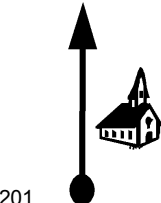

V 36

T71

201

2.15

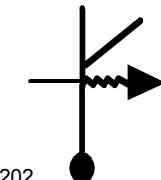

V 39 00.57.48

T72

202

2.46

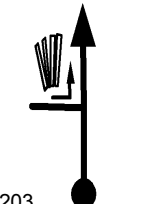

V 39

T72

203

COSTEAR CALIPO

2.56

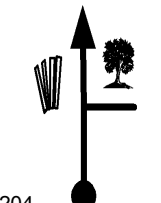

V 39

T72

204

COSTEAR ROÇA

2.69



V 30 00.58.38

T73 205

COSTEAR ROÇA

2.73

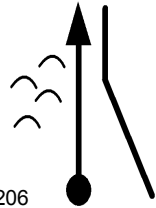

V 30

T73 206

2.75

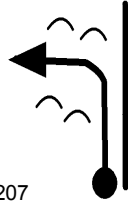

V 30

T73 207

2.95

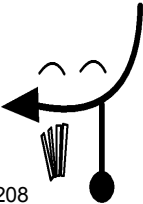

V 30

T73 208

3.02

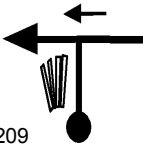

V 39 00.59.17

T74 209

COSTEAR CALIPO

3.10



V 39

T74 210

COSTEAR ROÇA

3.23



V 30 00.59.37

T75 211

COSTEAR ROÇA

3.26

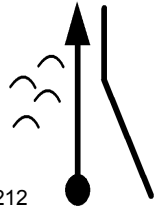

V 30

T75 212

3.29

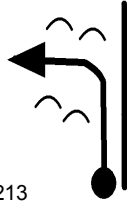

V 30

T75 213

3.45

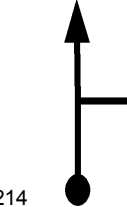

V 30

T75 214

3.48



V 27 01.00.07

T76 215

COSTEAR MATO

3.50



V 27

T76 216



COSTEAR MATO

NA DIREITA!

3.57

V 27

T76 217

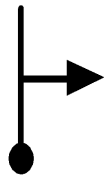

3.68

NI'30s 01.00.33

T77 218



3.68

V 30 01.02.03

T78 219

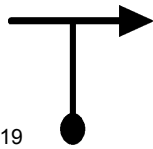

3.72

V 30

T78 220



4.09

V 30 01.02.53

T79 221



4.12

V 30

T79 222



4.14

V 30

T79 223



4.26

V 30

T79 224

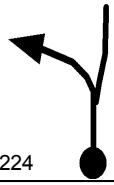

4.33

V 30

T79 225

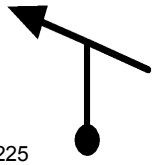

4.35

V 30

T79 226

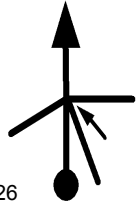

4.38

V 30

T79 227

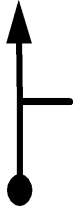



4.41

V 30

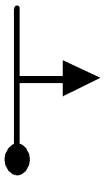
T79 228

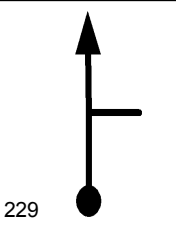
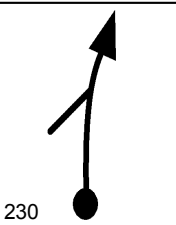
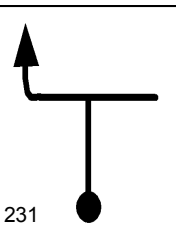
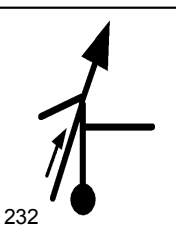
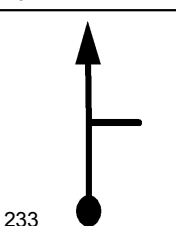
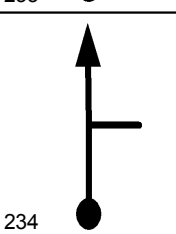

4.49	
V 30	
T79	229
4.51	
V 30	
T79	230
4.59	
V 30	
T79	231
4.88	
V 30	
T79	232
4.91	
V 30	
T79	233
4.94	
V 30	
T79	234

5.01	
NI'30s 01.04.43	
T80 235	

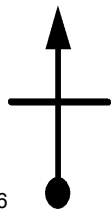
5.01	
V 30 01.06.13	
T81 236	

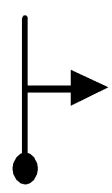
5.04	
V 30	
T81 237	

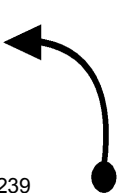

5.09	
V 30	
T81 238	

5.18	
V 30	
T81 239	



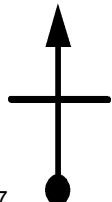
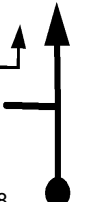
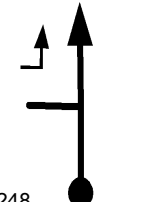
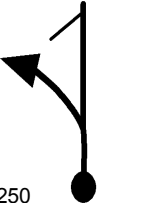

5.23	
V 30	
T81 240	

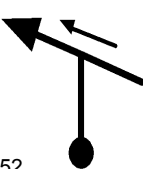
5.33	
V 30	
T81 241	
5.40	
V 30	
T81 242	
5.54	
V 30	
T81 243	
ATENCAO ABISMO	
5.58	
V 30	
T81 244	
5.73	
V 30 01.07.39	
T82 245	
5.75	
V 30 01.07.42	
T83 246	

5.83	
V 30	
T83	247
5.88	
V 30	
T83	248
5.94	
V 30	
T83	249
1	
6.01	
V 30	
T83	250
6.04	
V 30	
T83	251
6.09	
V 30	
T83	252

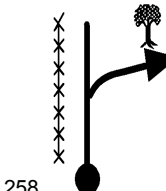
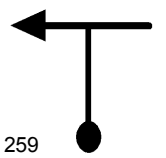
6.14	
V 30	
T83	253
ENTRE NO MATO	
6.25	
V 27 01.08.42	
T84	254
6.41	
V 27	
T84	255
COSTEAR MATO	
6.51	
V 27	
T84	256
COSTEAR CERCA	
DESCIDA	
6.75	
V 33 01.09.48	
T85	257

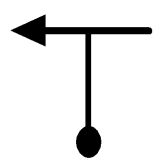
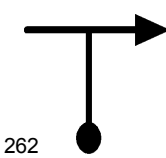
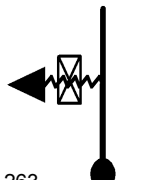
6.94	
V 36 01.10.09	
<b>T86</b>	258
7.00	
V 36	
<b>T86</b>	259
7.10	
NI'30s 01.10.25	
<b>T87</b>	260
7.10	
<b>0.00</b>	
V 36 01.11.55	
<b>T88</b>	261
0.70	
V 36	
<b>T88</b>	262
1.24	
V 33 01.13.59	
<b>T89</b>	263

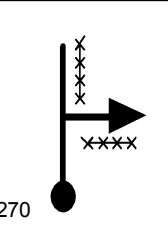

1.32	
V 33	
T89 264	
COSTEAR CERCA	
1.36	***** 
V 33	
T89 265	
Bamp	
1.57	
V 33	
T89 266	
1.67	
V 30 01.14.46	
T90 267	
PONTE PERIGOSA	
2.10	
V 30	
☠☠☠ T90 268	
2.21	
V 15 01.15.51	
T91 269	

2.22	
V 15	
T91 270	

2.26	
N 16' 01.16.03	
T92 271	

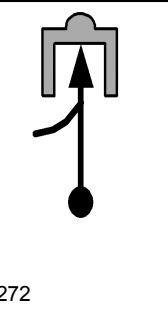
2.26	
0.00	
V 36 01.32.03	
T93 272	

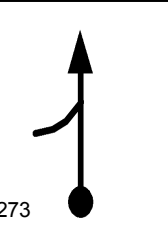
0.24	
V 36	
T93 273	

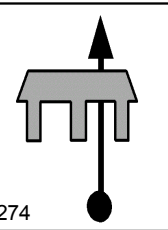
0.35	
V 36	
T93 274	

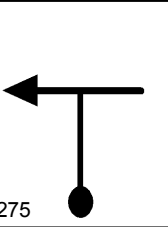
0.38	
V 36	
T93 275	

INICIO ASFALTO

1.88	
V 36	
T93	276

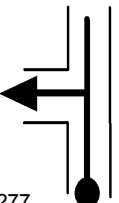
1.98	
V 36	
T93	277

2.31	
V 36	
T93	278

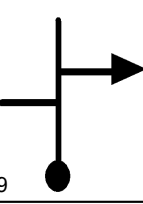
2.60	
V 30 01.36.23	
T94	279

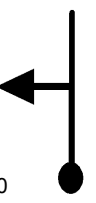
2.73	
V 30	
T94	280

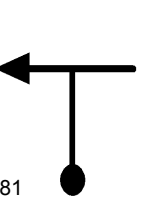
2.88	
V 30	
T94	281

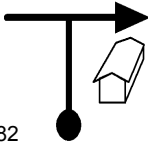
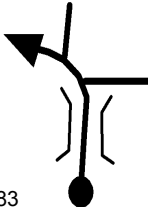
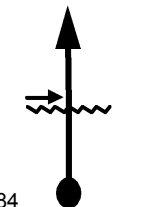
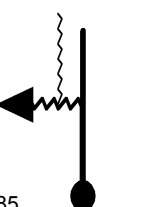
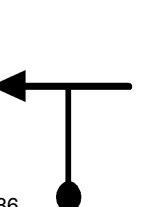
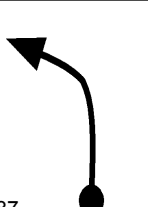
2.99	
V 36 01.37.10	
T95	282
3.35	
V 36	
T95	283
3.57	
V 36	
T95	284
3.84	
V 39 01.38.35	
T96	285
4.33	
V 39	
T96	286
4.46	
V 30 01.39.32	
T97	287

ATENÇÃO

4.72



V 30



T97

288

4.80



V 30

T97

289

4.93



N 1' 01.40.28

T98

290

4.93

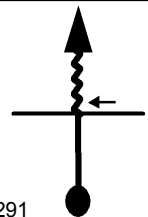

V 30 01.41.28

T99

291

5.23

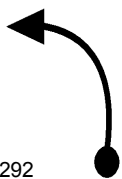

V 30

T99

292

5.45



V 30

T99

293

5.60	
V 30	
T99	294
5.69	
V 30	
T99	295
5.72	
V 30	
T99	296
5.80	
V 27 01.43.13	
T100	297
6.06	
V 30 01.43.47	
T101	298
6.23	
0.00	
V 30 01.44.08	
T102	299



0.36	
V 27 01.44.51	
<b>T103</b> 300	

0.53	
V 27	
<b>T103</b> 301	

0.64	
N 1' 01.45.28	
<b>T104</b> 302	

NÃO ERRE

0.64	
V 30 01.46.28	
<b>T105</b> 303	

0.78	
V 30	
<b>T105</b> 304	

0.87	
V 27 01.46.56	
T106	305

1.08	
V 27	
T106	306

1.17	
V 27	
T106	307

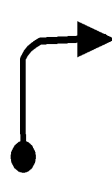

1.52	
V 27	
T106	308

1.60	
V 27	
T106	309

PELO TRILHO  
DO GADO

1.69	
V 27	
T106	310

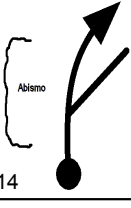
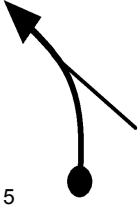
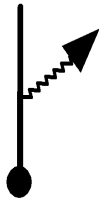

1.79	
N 2' 01.48.58	
T107	311
1.79	
V 30 01.50.58	
T108	312
1.81	
V 30	
T108	313
1.94	
V 30	
T108	314
2.03	
V 30	
T108	315
2.06	
V 27 01.51.31	
T109	316

2.44	
V 27	
T109	
2.45	
V 27	
T109	
2.76	
V 30 01.53.04	
T110	
2.80	
V 30	
T110	
2.90	
V 30 01.53.21	
T111	
3.09	
V 30	
T111	

BAMP

3.14

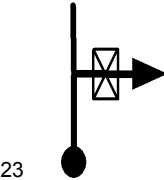

V 39 01.53.50

T112 323

COSTEAR CERCA

3.32

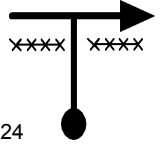

V 33 01.54.06

T113 324

COSTEAR MATO

3.44



V 33

T113 325

COSTEAR MATO

3.58

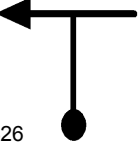

V 33

T113 326

COSTEAR MATO

3.80



V 33

T113 327

COSTEAR CERCA

3.89

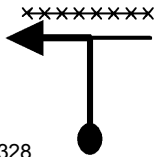

V 33

T113 328

3.97

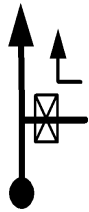

V 33

T113 329

COSTEAR MATO

4.09

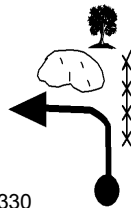

V 33

T113 330

4.23

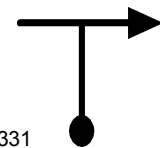

V 24 01.55.46

T114 331

4.27



N 2' 01.55.52

T115 332

4.27

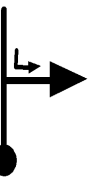

V 30 01.57.52

T116 333

4.55



N 30s 01.58.25

T117 334

ATENÇÃO

4.55

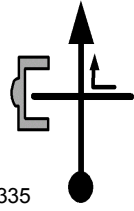

V 30 01.58.55

T118 335

4.59

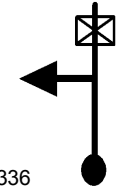

V 30 01.59.00

T119 336

5.06

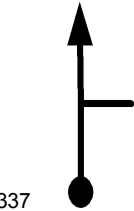

V 33 01.59.56

T120 337

COSTEAR BANANEIRA

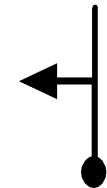

5.24



0.00

V 33 02.00.16

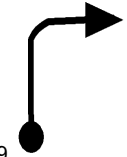
T121 338

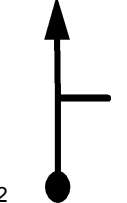
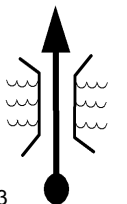
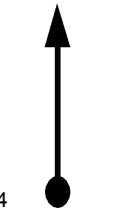
0.36	
V 33	
T121	339
0.40	
V 27 02.01.00	
T122	340
0.52	
V 27	
T122	341
0.70	
V 24 02.01.40	
T123	342
0.74	
V 27 02.01.46	
T124	343
COSTEAR MATO	
0.96	
V 27	
T124	344

NÃO ERRE

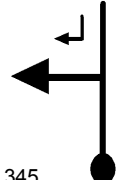
1.07	
V 30 02.02.30	
<b>T125</b>	345

1.34	
NI'30s 02.03.02	
<b>T126</b>	346

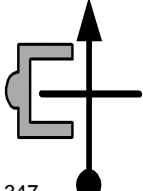
1.34	
V 30 02.04.32	
<b>T127</b>	347

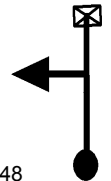
1.37	
V 30 02.04.36	
<b>T128</b>	348

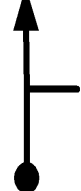
1.86	
V 33 02.05.35	
<b>T129</b>	349

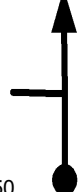
2.04	
V 33	
<b>T129</b>	350

ENTRE NO MATO

2.10	
V 33	
T129 351	

2.12	
V 24 02.06.03	
T130 352	

2.44	
V 27 02.06.51	
T131 353	

COSTEAR MATO





2.69	
V 30 02.07.24	
T132 354	

2.78	
V 30	
T132 355	

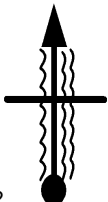

2.90	
V 30	
T132 356	

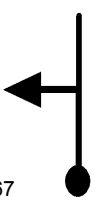

2.94	
V 30	
T132	357
CUIDADO DESCIDA	
3.13	
V 24 02.08.17	
T133	358
SE PREPARA !!	
3.39	
V 9 02.08.56	
T134	359
3.42	
V 9	
T134	360
3.44	
V 9	
T134	361

3.52	
V 9	
T134 362	
ARVORE	
POR BAIXO	
3.61	
V 9	
T134 363	
3.63	
V 30 02.10.32	
T135 364	
3.85	
V 9 02.10.58	
T136 365	
3.94	
N 4' 02.11.34	
T137 366	
3.94	
V 30 02.15.34	
T138 367	

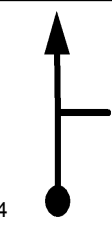
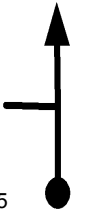
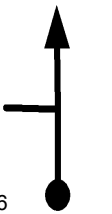
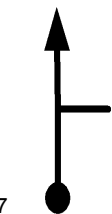
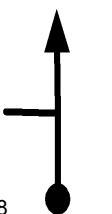
4.00	
V 30	
T138	368
4.04	
V 30	
T138	369
4.14	
V 30 02.15.58	
T139	370
4.33	
V 30	
T139	371
4.42	
V 30	
T139	372
4.46	
V 30 02.16.37	
T140	373

4.94	
V 33 02.17.34	
T141	374
5.12	
V 33	
T141	375
5.17	
V 33	
T141	376
5.19	
V 30 02.18.02	
T142	377
5.31	
V 30	
T142	378
5.42	
V 30	
T142	379

COSTEAR MATO

5.53

V 30

T142 380

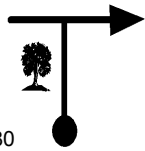

5.68

V 30

T142 381

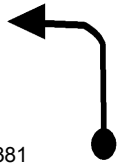

5.77

V 27 02.19.11

T143 382



5.80

V 39 02.19.15

T144 383

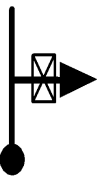

5.95

V 39

T144 384

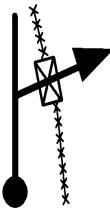

6.00

V 30 02.19.34

T145 385

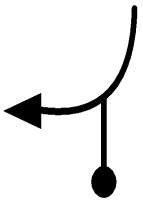

6.34	
NI'30s 02.20.15	
<b>T146</b>	386

6.34	
<b>0.00</b>	
V 30 02.21.45	
<b>T147</b>	387

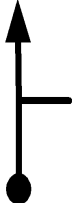
0.72	
V 30	
<b>T147</b>	388

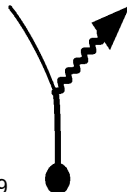
0.78	
V 30 02.23.18	
<b>T148</b>	389

COSTEAR CALIPO

0.84	
V 30	
<b>T148</b>	390

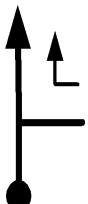
1.04	
V 30	
<b>T148</b>	391

<h1>1.09</h1>	
<b>V 30</b>	
<b>T148</b>	<small>392</small>

<h1>1.15</h1>	
<b>V 30</b>	
<b>T148</b>	<small>393</small>

COSTEAR MATO

<h1>1.23</h1>	
<b>V 30</b>	
<b>T148</b>	<small>394</small>

<h1>1.33</h1>	
<b>V 30</b>	
<b>T148</b>	<small>395</small>

COSTEAR MATO

<h1>1.38</h1>	
<b>V 30</b>	
<b>T148</b>	<small>396</small>

<h1>1.47</h1>	
<b>V 30</b>	
<b>T148</b>	<small>397</small>

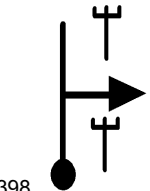
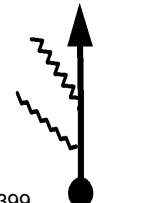
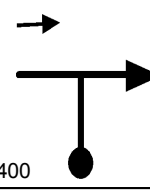
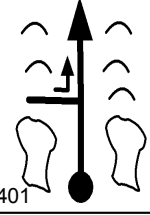
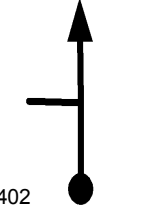
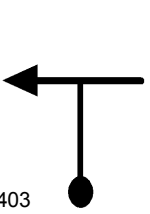
1.57	
V 30	
T148	398
COSTEAR BANANEIRA	
1.63	
V 30	
T148	399
1.70	
V 30	
T148	400
1.73	
V 30	
T148	401
1.81	
V 30	
T148	402
1.89	
V 30	
T148	403



BAMP

1.90

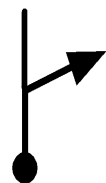

V 27 02.25.33

T149 404

1.96

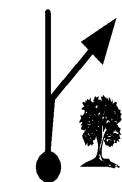

V 27

T149 405

BAMP

2.00

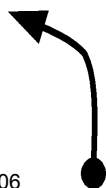

V 27

T149 406

ENTRE NO MATO

2.13



V 30 02.26.03

T150 407

2.39



V 30

T150 408

2.64

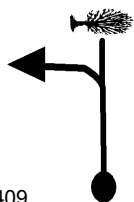

V 21 02.27.04

T151 409

2.67	
V 30 02.27.10	
T152	410
2.79	
N 1' 02.27.24	
T153	411
COSTEAR MATO	
2.79	
V 30 02.28.24	
T154	412
2.84	
V 30	
T154	413
2.93	
V 30	
T154	414
3.03	
V 30	
T154	415

3.09	
V 30	
T154	416

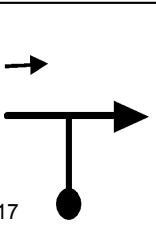
3.16	
V 30	
T154	417

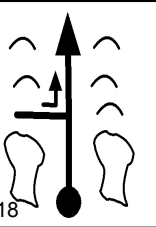
3.20	
V 30	
T154	418

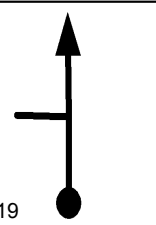
3.27	
V 30	
T154	419

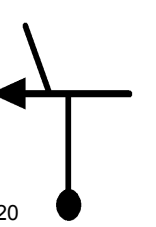

COSTEAR PARREIRA DE UVA

3.35	
V 30	
T154	420

CEPOS

3.42

V 30

T154<sup>421</sup>



COSTEAR MATO

3.48

V 27 02.29.47

T155<sup>422</sup>



COSTEAR MATO

3.59

V 27

T155<sup>423</sup>



COSTEAR MATO

3.62

V 27

T155<sup>424</sup>









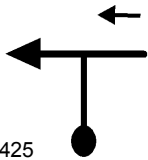

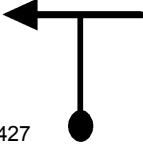

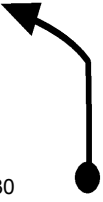
3.73

V 30 02.30.20

T156<sup>425</sup>

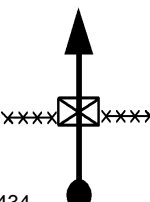

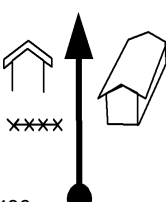
3.79	
V 30	
T156	426
3.87	
V 30	
T156	427
BAMP	
3.88	
V 27 02.30.38	
T157	428
BAMP	
3.94	
V 27	
T157	429
3.99	
V 27	
T157	430
ENTRE NO MATO	
4.12	
V 30 02.31.10	
T158	431

4.38	
V 21 02.31.41	
<b>T159</b>	432
4.59	
V 21	
<b>T159</b>	433
4.70	
V 21 02.32.36	
<b>T160</b>	434
4.73	
N 1' 02.32.41	
<b>T161</b>	435
4.73	
V 21 02.33.41	
<b>T162</b>	436
4.77	
V 21	
<b>T162</b>	437

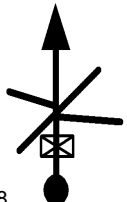
4.86	
V 33 02.34.04	
<b>T163</b>	438

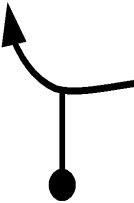
5.80	
<b>0.00</b>	
V 33 02.35.46	
<b>T164</b>	439

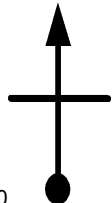
0.53	
V 33	
<b>T164</b>	440

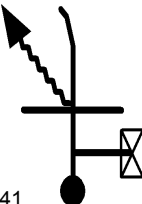
1.64	
V 30 02.38.45	
<b>T165</b>	441

COSTEAR MATO

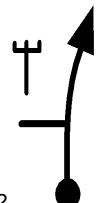

2.14	
V 30	
<b>T165</b>	442

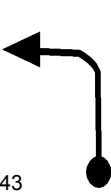

COSTEAR MATO

2.67	
V 30	
<b>T165</b>	443



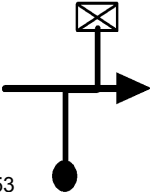
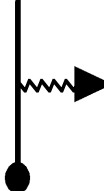
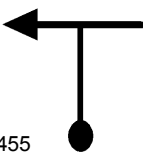

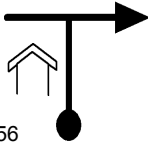
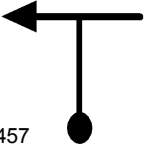
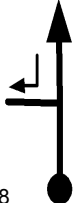
2.77	
V 30	
T165	444
3.00	
V 30	
T165	445
3.07	
V 30	
T165	446
3.25	
V 30	
T165	447
3.70	
V 30	
T165	448
3.73	
V 27 02.42.56	
T166	449

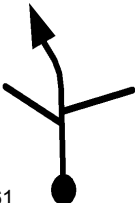

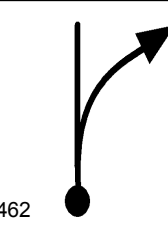
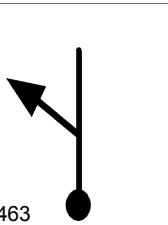
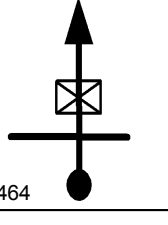
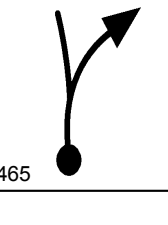
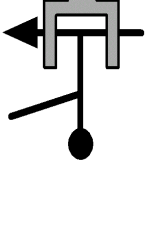
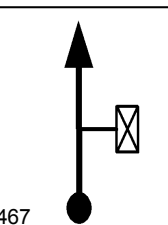

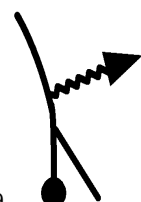
3.78	
N 1' 02.43.02	
<b>T167</b>	450
3.78	
V 27 02.44.02	
<b>T168</b>	451
MATA BURRO	
3.83	
V 33 02.44.09	
<b>T169</b>	452
4.06	
V 30 02.44.34	
<b>T170</b>	453
4.30	
V 27 02.45.03	
<b>T171</b>	454
4.47	
V 27	
<b>T171</b>	455

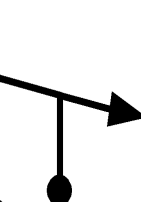
4.50	
V 30 02.45.30	
T172	456
4.64	
V 30	
T172	457
4.74	
V 30	
T172	458
4.83	
V 36 02.46.09	
T173	459
5.03	
V 36	
T173	460
5.69	
V 36	
T173	461

5.83	
V 36	
T173 462	
ENTRE NO CALIPAL	
5.89	
V 33 02.47.55	
T174 463	
5.91	
V 33	
T174 464	
6.17	
V 33	
T174 465	
6.39	
0.00	
V 33 02.48.50	
T175 466	
0.08	
V 33	
T175 467	

0.65	
V 33	
T175	468
0.70	
V 30 02.50.06	
T176	469
0.93	
V 30	
T176	470
0.99	
V 30	
T176	471
1.09	
V 30	
T176	472
1.21	
V 30	
T176	473

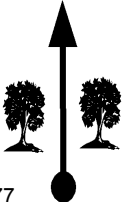
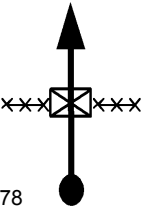
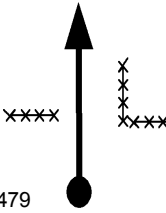
1.34	
V 30	
T176 <sup>474</sup>	
BAMP	
1.47	
V 30	
T176 <sup>475</sup>	
1.53	
V 30	
T176 <sup>476</sup>	
1.57	
V 30	
T176 <sup>477</sup>	
1.72	
V 30	
T176 <sup>478</sup>	
COSTEAR CERCA	
1.87	
V 30	
T176 <sup>479</sup>	



COSTEAR CERCA

1.95	
V 30	
T176 480	

2.02	
V 30	
T176 481	





BAMP

2.08	
V 30	
T176 482	

2.20	
V 27 02.53.06	
T177 483	

2.35	
V 27	
T177 484	

2.39	
V 27	
T177	485
BAMP	
2.44	
V 33 02.53.38	
T178	486
BAMP	
2.71	
V 33	
T178	487
BAMP	
2.78	
V 21 02.54.15	
T179	488
TRILHO DO GADO	
2.82	
V 24 02.54.22	
T180	489
COSTEAR CERCA	
2.89	
V 33 02.54.33	
T181	490

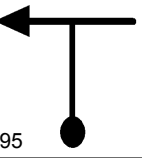
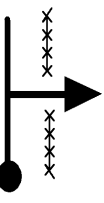
3.25	
V 30 02.55.12	
<b>T182</b>	491
3.42	
NI'30s 02.55.32	
<b>T183</b>	492
3.42	
V 15 02.57.02	
<b>T184</b>	493
3.49	
V 15	
<b>T184</b>	494
3.58	
V 30 02.57.41	
<b>T185</b>	495
BAMP	
3.61	
V 30 02.57.44	
<b>T186</b>	496



3.71	
V 30	
T186 497	
COSTEAR CERCA	
3.74	
V 30	
T186 498	
BAMP	
3.95	
V 30	
T186 499	
4.06	
V 27 02.58.38	
T187 500	
PONTE PERIGOSA	
4.48	
V 27	
T187 501	
4.58	
V 15 02.59.48	
T188 502	

4.60

V 15

T188

503

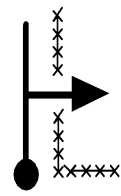

4.64

V 15 03.00.02

T188

504



**FIM DE PROVA !!**



[www.t15.com.br](http://www.t15.com.br)

**Tempo de Prova**

MÉDIA C 03:00:02

**FIM**