

INICIO

MÉDIA A







6 ENDURO AMIGOS NA TRILHA
01 e 02 de Janeiro / 2015



IMPORTANTE

PLANILHA TERMICA
FITA ADESIVA DO LADO DE
TRÁS. NÃO USE CANETA
MARCA TEXTO,
USE CANETA ESFEROGRÁFICA
OU HIDROGRÁFICA

DIRETORES DE PROVA:
DIOGES OSELLAME
CLEBSON OSELLAME
REALIZAÇÃO: AMIGOS NA TRILHA
NOS TRECHOS URBANOS
PREVALECEM AS LEIS
DO CÓDIGO NACIONAL
DE TRANSITO. É OBRIGAÇÃO
RESPEITAR AS
PROPRIEDADES
ALHEIAS E OS MORADORES.
A ORGANIZAÇÃO NÃO SE
RESPONSABILIZA POR PASSAR
PROGRAMAÇÃO DE NAVEGAÇÃO.
É OBRIGAÇÃO DO PILOTO
CONFERIR A PROGRAMAÇÃO DO
NAVEGADOR.
LARGADA - 14:00 HS
CTG TIO MILLO
NEUTRO PRINCIPAL
LOCAL DA LARGADA
CHEGADA NO MESMO
LOCAL DA LARGADA
1 ETAPA KM
2 ETAPA KM
TOTAL KM
LEVANTAMENTO DA PROVA
COM MOTO CRF 230 COM
PNEU DIANTEIRO NOVO
E 12 LIBRAS

 **CUIDADO**
  **ATENÇÃO**
   **MUITA ATENÇÃO**



Tempo de Prova

MÉDIA A 02:50:46







AFERIÇÃO

AFERIR

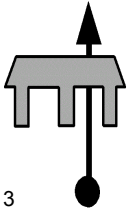
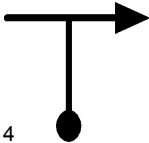
0.00	
AFER	1

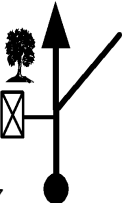
0.24	
AFER	2

0.35	
AFER	3
0.37	
AFER	4
LOMBADA	
0.63	
AFER	5
1.46	
AFER	6
1.76	
AFER	7
AFERIR!!	
2.220	
0.00	
AFER	8



INICIO DE PROVA

BOA SORTE!!

0.00 V 25 00.00.00 T1	
0.24 V 25 T1	
0.41 V 25 T1	
0.54 V 25 T1	
0.58 V 21 00.01.24 T2	

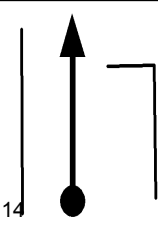
0.74	
V 21	
T2	14

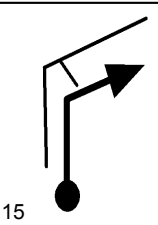
0.76	
V 21	
T2	15

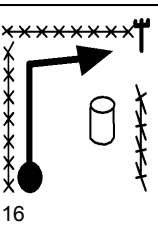
0.78	
V 21	
T2	16

por baixo da casinha

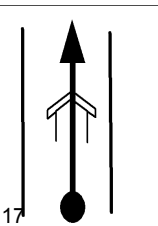
0.91	
V 21	
T2	17

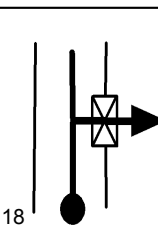
0.94	
V 21	
T2	18

costear cerca

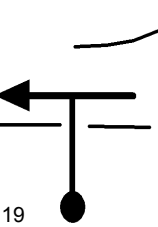
0.95	
V 21 00.02.27	
T3	19

0.99	
V 21	
T3	20

bamp

1.01	
V 21	
T3	21

1.03	
V 36 00.02.41	
T4	22

1.05	
V 36	
T4	23

PONTE!!

PERIGO!

1.14	
V 36	
T4	24

BAMP

1.58	
V 36	
T4	25

COSTEAR MATO!!

1.67

V 36

T4

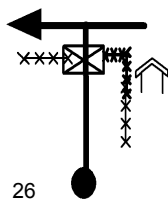

26

COSTEAR MATO!!

1.85

V 36

T4

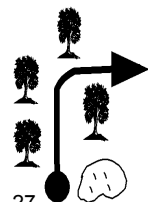

27

COSTEAR MATO!!

1.96

V 36

T4

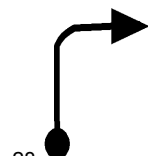

28

2.20

V 36

T4



29

BAMP

2.24

V 36

T4



30

BAMP

2.26

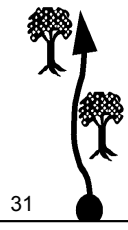

V 36

T4

2.31

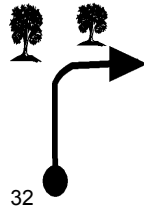

V 33 00.04.49

T5

VALO

2.34

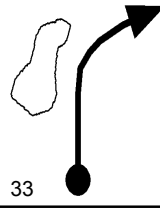

V 33

T5

VALO

2.37



V 33

T5





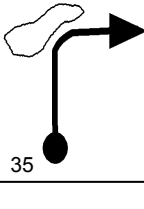

VALO

2.39

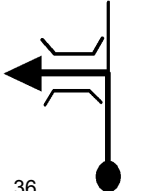

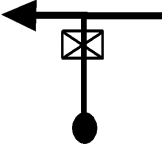
V 33

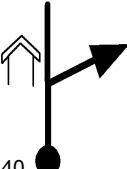
T5

2.43	
V 33	
T5	36
2.52	
NI'30s 00.05.12	
T6	37
2.52	
0.00	
V 20 00.06.42	
T7	38
0.04	
V 20	
T7	39
0.13	
V 20	
T7	40
0.18	
V 20	
T7	41

<h1>0.20</h1>	
V 36 00.07.18	42
T8	

COSTEAR CERCA

<h1>0.36</h1>	
V 36	43
T8	

COSTEAR CERCA

<h1>0.72</h1>	
V 36	44
T8	

<h1>0.83</h1>	
V 36	45
T8	

<h1>1.16</h1>	
V 36	46
T8	

COSTEAR CERCA

<h1>1.26</h1>	
V 36	47
T8	

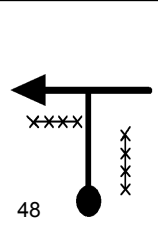
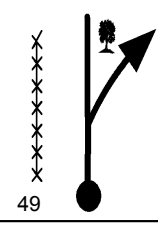
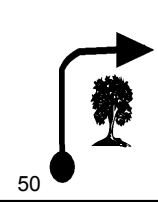
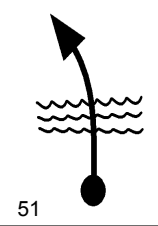
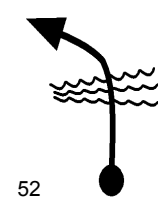
1.61	
V 33 00.09.39	
T9	48
PELO	
TRILHO	
DO	
GADO!!	
1.64	
V 33	
T9	49
1.68	
V 33	
T9	50
BAMP	
1.70	
V 33	
T9	51
DENTRO DO RIO	
BAMP	
1.74	
V 39 00.09.53	
T10	52

1.80	
V 39	
T10	53
BAMP	
1.96	
V 39	
T10	54
ENTRE NO MATO	
2.06	
V 33 00.10.22	
T11	55
2.12	
V 33	
T11	56
2.16	
V 33	
T11	57
COSTEAR CERCA	
2.31	
V 36 00.10.50	
T12	58

2.46

V 36

T12

59

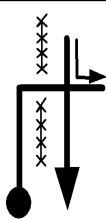

BAMP

2.52

V 36

T12

60



BAMP

2.58

V 36

T12

61

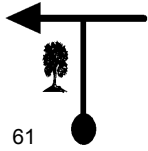

2.61

V 36

T12

62

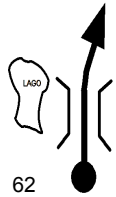

COSTEAR CERCA

2.65

V 36

T12

63

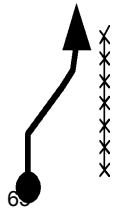

2.71	
V 36	
T12	64

COSTEAR CERCA

2.73	
V 36	
T12	65

2.83	
N 2' 00.11.42	
T13	66

2.83	
V 33 00.13.42	
T14	67

2.89	
V 33	
T14	68

2.90	
V 33	
T14	69

NAO ERRE

2.95



V 33



T14

70

3.01



V 36 00.14.01

T15

71

3.09

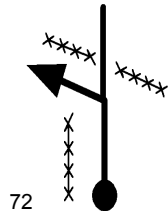

V 36

T15

72

BAMP

3.16



V 36

T15

73

COSTEAR CERCA

3.26

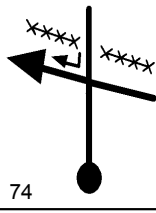

V 36

T15

74

3.43

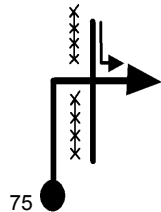

V 33 00.14.43

T16

75

NAO ERRE

3.49

V 33

T16



3.54

V 36 00.14.55

T17



COSTEAR CERCA

3.63

V 36

T17

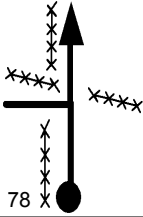

COSTEAR CERCA

3.69

V 36

T17

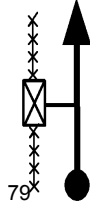

COSTEAR CALIPO

DA ESQUERDA

3.78

V 36

T17

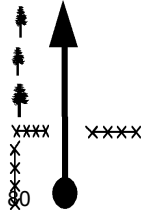

ATENÇÃO

3.92

V 36



T17

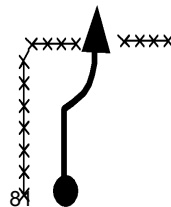

COESTEAR EUCALIPTO

4.06

V 36

T17

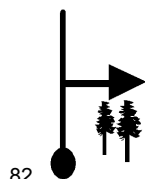

CUIDADO CEPO

4.11

V 30 00.15.52

T18

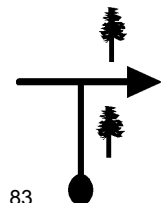

BAMP

4.18

V 30

T18



BAMP

4.25

V 30

T18

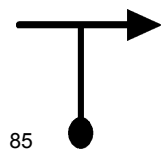

BAMP

4.30

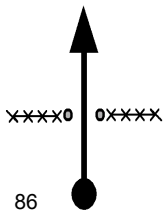

V 30

T18

86

4.34

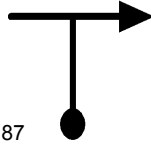

V 30

T18

87

4.37

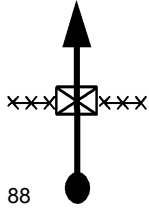

V 30

T18

88

4.38



V 30

T18

89

4.47

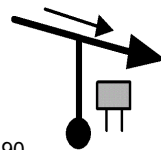

V 36 00.16.35

T19

90

PERIGO!!

4.54

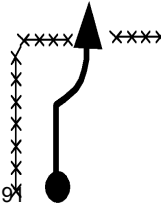

V 36

T19

91



BAMP

4.68

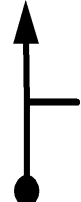

V 27 00.16.56

T20

92

4.73

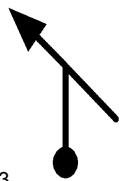

V 27

T20

93

4.79

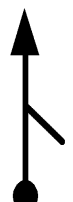

V 27

T20

94

4.92

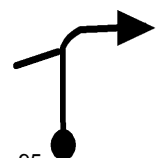

V 39 00.17.28

T21

95

5.06



V 39

T21

96

5.18





V 39

T21

97

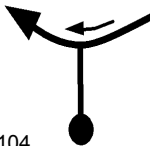
5.30	
V 39	
T21	98
5.61	
N 2' 00.18.32	
T22	99
5.61	
0.00	
V 30 00.20.32	100
T23	
0.12	
V 33 00.20.46	
T24	101
0.29	
V 33	
T24	102
BURACO	
PELA DIREITA	
0.31	
V 33	
	T24
	103

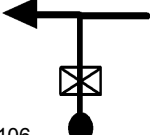
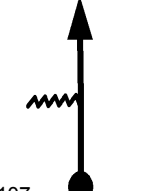
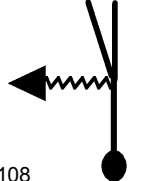
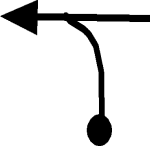
0.35	
V 39 00.21.12	
T25	104
0.66	
N 1' 00.21.40	
T26	105
0.66	
V 30 00.22.40	
T27	106
0.78	
V 30	
T27	107
1.08	
V 33 00.23.31	
T28	108
1.31	
V 33	
T28	109

POSTE TBG

1.34	
V 33	
T28 110	

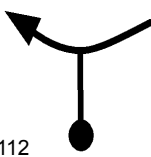

1.58	
V 33	
T28 111	

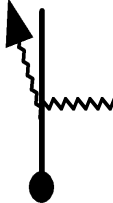
1.76	
V 30 00.24.45	
T29 112	

2.01	
V 45 00.25.15	
T30 113	

2.05	
V 45	
T30 114	

EROSÕES

2.27	
V 33 00.25.36	
 T31 115	

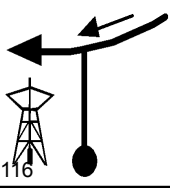
2.51	
V 36 00.26.02	
T32	116

BAMP

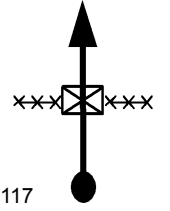
2.64	
V 36	
T32	117

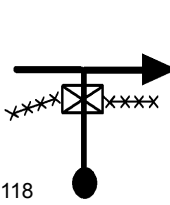
2.71	
V 36	
T32	118

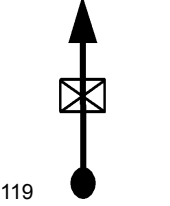
2.82	
V 36	
T32	119

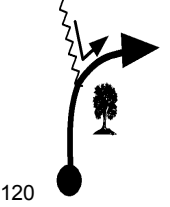

2.87	
V 39 00.26.38	
T33	120

3.14	
V 39	
T33 121	

3.16	
V 39	
T33 122	

3.21	
V 39	
T33 123	

3.26	
V 39	
T33 124	

EROSÕES

3.36	
V 36 00.27.23	
T34 125	

3.42	
V 36	
T34 126	

BAMP

3.54

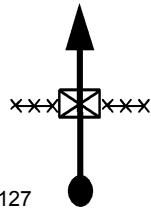

V 36

T34 127

3.63

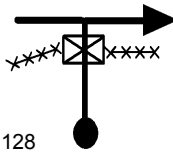

V 36

T34 128

3.77

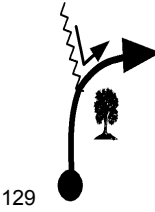

V 39 00.28.04

T35 129

4.04



V 39

T35 130

COSTEAR CERCA

4.25



V 33 00.28.48

T36 131

BAMP

4.43

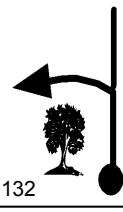

V 36 00.29.08

T37 132

4.52	
V 36	
T37	133

4.63	
V 36	
T37	134

4.77	
V 36	
T37	135

4.99	
V 36	
T37	136

COSTEAR CERCA

5.04	
V 36	
T37	137

BAMP

5.10	
V 27 00.30.15	
T38	138

5.20



N 2' 00.30.28

T39 139

ATENÇÃO

5.20

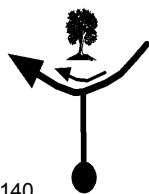

V 39 00.32.28

T40 140

5.47



V 39

T40 141

5.68



V 36 00.33.12

T41 142

5.86



V 36

T41 143

5.90



N 1' 00.33.34

T42 144

5.90	
V 27 00.34.34	
T43	145
6.13	
0.00	
V 30 00.35.05	
T44	146
0.15	
V 30	
T44	147
0.26	
V 39 00.35.36	
T45	148
0.36	
V 39	
T45	149
0.51	
V 39	
T45	150

0.60	
V 27 00.36.08	
T46	151

0.63	
V 27	
T46	152

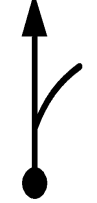
0.66	
V 39 00.36.16	
T47	153



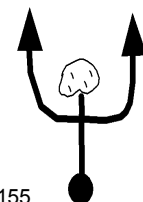

0.82	
V 39	
T47	154

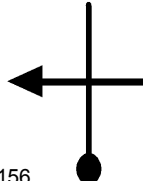
ESCOLHA!

0.93	
V 33 00.36.41	
T48	155

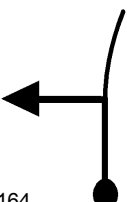
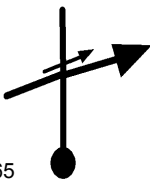
0.96	
V 39 00.36.44	
T49	156

1.25	
V 39	
T49	157
ATENÇÃO!!	
1.29	
V 39	
T49	158
ATENÇÃO!!	
1.48	
V 39	
T49	159
1.66	
V 39	
T49	160
1.89	
NI'30s 00.38.10	
T50	161
1.89	
V 30 00.39.40	
T51	162

2.00	
V 36 00.39.53	
T52	163
2.20	
V 36	
T52	164
ATENÇÃO	
2.35	
V 39 00.40.28	
 T53	165
2.43	
V 27 00.40.35	
T54	166
2.46	
V 27	
T54	167
2.50	
V 39 00.40.45	
T55	168

2.67	
V 39	
T55	169

2.78	
V 33 00.41.11	
T56	170

2.81	
V 36 00.41.14	
T57	171

3.04	
V 36	
T57	172

3.15	
V 36	
T57	173

COSTEAR CERCA

3.20	
V 39 00.41.53	
T58	174

COSTEAR MATO

3.25

V 39

T58 175



3.43

V 33 00.42.14

T59 176



3.50

V 33

T59 177

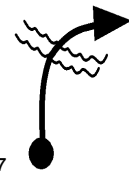

ACELERE!!

3.64

V 33

T59 178

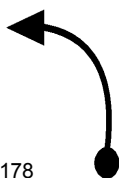

BAMP

3.72

V 30 00.42.46

T60 179



3.84

N 2' 00.43.00

T61 180



NÃO ERRE

3.84

V 39 00.45.00

T62

181



4.03

V 39

T62

182



4.16

V 27 00.45.30

T63

183



NAO ERRE!

POSTE TBG

4.27

V 36 00.45.44



T64

184



4.50

V 36

T64

185

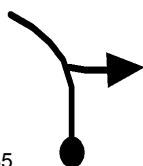

4.54

V 36

T64

186



ENTRE NO

CALIPAL

4.57

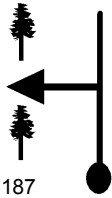

V 36

T64

187

4.77

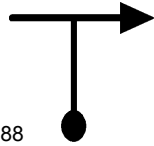

V 30 00.46.34

T65

188

4.80



V 30

T65

189

4.83

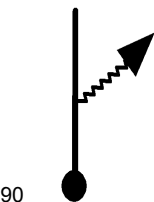

V 36 00.46.41

T66

190

4.99

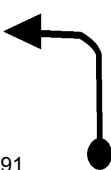

V 36

T66

191

5.09

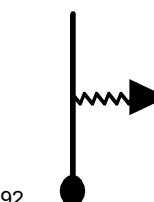

V 33 00.47.07

T67

192

ATOLEIRO!

5.64

V 33

T67

193



5.79

N 1' 00.48.24

T68

194



5.79

0.00

V 30 00.49.24

T69

195

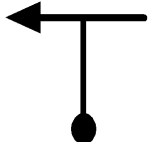

0.23

V 30

T69

196



0.32

V 30

T69

197

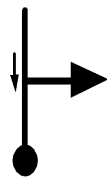

0.64

V 36 00.50.41

T70

198



CUIDADO ESTRADA!

0.79

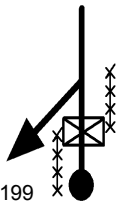

V 36 00.50.56



T71

199

1.29

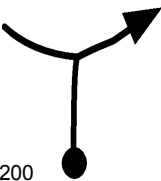

V 36

T71

200

2.00

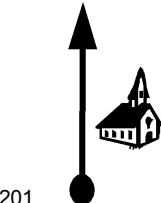

V 36

T71

201

2.15

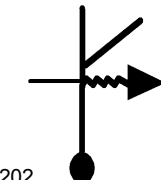

V 45 00.53.12

T72

202

2.46

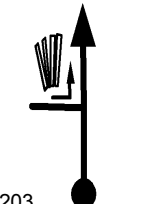

V 45

T72

203

COSTEAR CALIPO

2.56

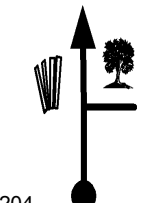

V 45

T72

204

COSTEAR ROÇA

2.69



V 36 00.53.55

T73 205

COSTEAR ROÇA

2.73

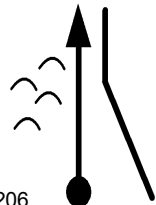

V 36

T73 206

2.75

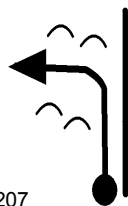

V 36

T73 207

2.95

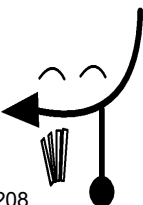

V 36

T73 208

3.02

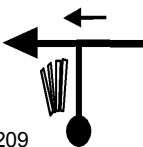

V 45 00.54.28

T74 209

COSTEAR CALIPO

3.10

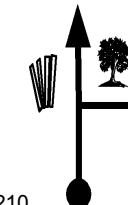

V 45

T74 210

COSTEAR ROÇA

3.23



V 36 00.54.45

T75 211

COSTEAR ROÇA

3.26

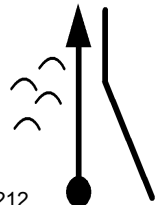

V 36

T75 212

3.29

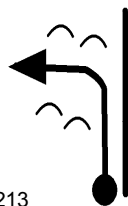

V 36

T75 213

3.45

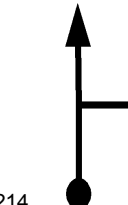

V 36

T75 214

3.48

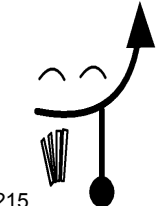

V 33 00.55.10

T76 215

COSTEAR MATO

3.50



V 33

T76 216

COSTEAR MATO

NA DIREITA!

3.57

V 33

T76 217

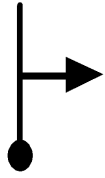

3.68

N 2' 00.55.31

T77 218



3.68

V 30 00.57.31

T78 219

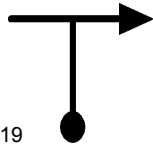

3.72

V 30

T78 220



4.09

V 36 00.58.21

T79 221



4.12

V 36

T79 222



4.14

V 36

T79 223

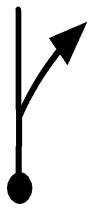

4.26

V 36

T79 224

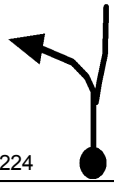

4.33

V 36

T79 225

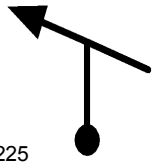

4.35

V 36

T79 226

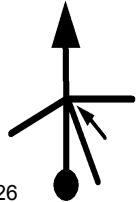

4.38

V 36

T79 227

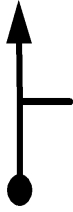



4.41

V 36

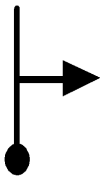
T79 228

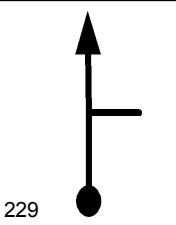
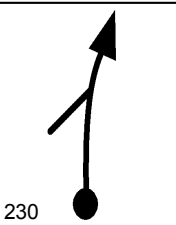
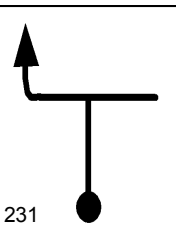
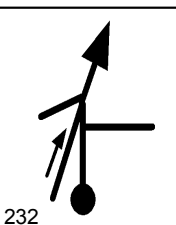
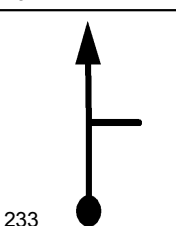
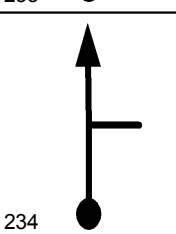

4.49	
V 36	
T79	229
4.51	
V 36	
T79	230
4.59	
V 36	
T79	231
4.88	
V 36	
T79	232
4.91	
V 36	
T79	233
4.94	
V 36	
T79	234

5.01	
NI'30s 00.59.53	
T80 235	

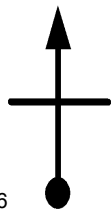
5.01	
V 36 01.01.23	
T81 236	

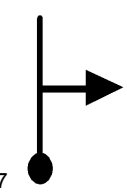
5.04	
V 36	
T81 237	

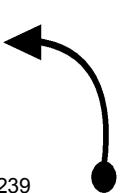

5.09	
V 36	
T81 238	

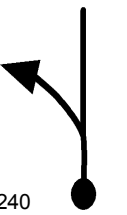

5.18	
V 36	
T81 239	



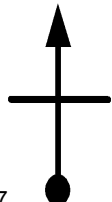
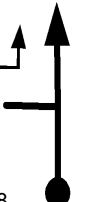
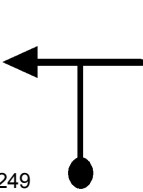
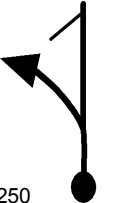

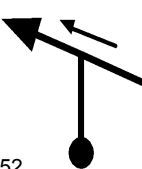
5.23	
V 36	
T81 240	

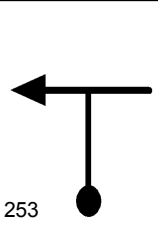
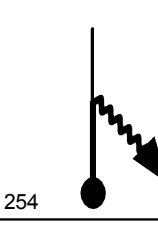
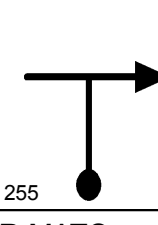
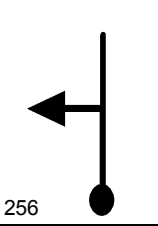
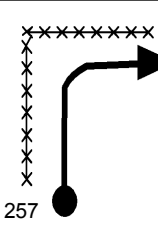
5.33	
V 36	
T81 241	
5.40	
V 36	
T81 242	
5.54	
V 36	
T81 243	
ATENCAO ABISMO	
5.58	
V 36	
☠☠☠ T81 244	
5.73	
V 30 01.02.35	
T82 245	
5.75	
V 36 01.02.37	
T83 246	

5.83	
V 36	
T83	247
5.88	
V 36	
T83	248
5.94	
V 36	
T83	249
1	
6.01	
V 36	
T83	250
6.04	
V 36	
T83	251
6.09	
V 36	
T83	252

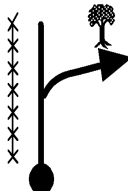
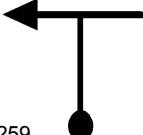
6.14	
V 36	
T83	253
ENTRE NO MATO	
6.25	
V 33 01.03.27	
T84	254
6.41	
V 33	
T84	255
COSTEAR MATO	
6.51	
V 33	
T84	256
COSTEAR CERCA	
DESCIDA	
6.75	
V 39 01.04.22	
 T85	257

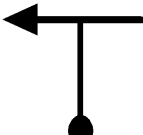
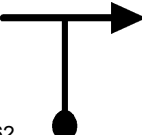
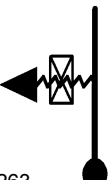
6.94	
V 42 01.04.39	
T86	258
7.00	
V 42	
T86	259
7.10	
NI'30s 01.04.53	
T87	260
7.10	
0.00	
V 36 01.06.23	
T88	261
0.70	
V 36	
T88	262
1.24	
V 39 01.08.27	
T89	263

1.32	
V 39	
T89 264	
COSTEAR CERCA	
1.36	*****
V 39	
T89 265	
Bamp	
1.57	
V 39	
T89 266	
1.67	
V 36 01.09.06	
T90 267	
PONTE PERIGOSA	
2.10	
V 36	
☠☠☠ T90 268	
2.21	
V 15 01.10.00	
T91 269	

2.22	
V 15	
T91	

270

2.26	
N 20' 01.10.12	
T92	

271

2.26	
0.00	
V 36 01.30.12	
T93	

272

0.24	
V 36	
T93	

273

0.35	
V 36	
T93	

274

0.38	
V 36	
T93	

275

INICIO ASFALTO

1.88	
V 36	
T93	276

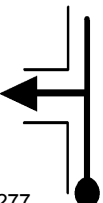

1.98	
V 36	
T93	277

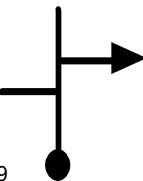
2.31	
V 36	
T93	278

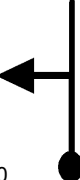
2.60	
V 30 01.34.32	
T94	279

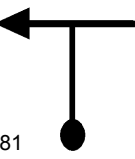
2.73	
V 30	
T94	280

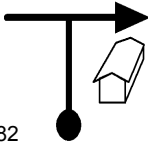
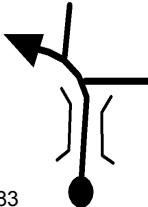
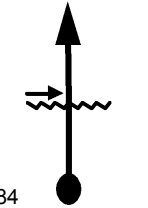
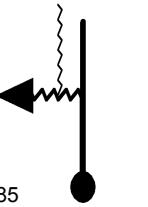
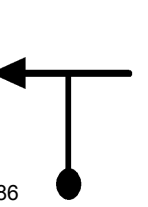
2.88	
V 30	
T94	281

2.99	
V 36 01.35.19	
T95	282
3.35	
V 36	
T95	283
3.57	
V 36	
T95	284
3.84	
V 45 01.36.44	
T96	285
4.33	
V 45	
T96	286
4.46	
V 36 01.37.34	
T97	287

ATENÇÃO

4.72



V 36



T97

288

4.80



V 36

T97

289

4.93



N 1' 01.38.21

T98

290

4.93

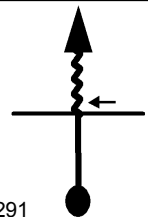

V 36 01.39.21

T99

291

5.23

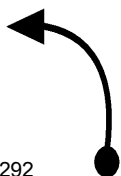

V 36

T99

292

5.45



V 36

T99

293

5.60	
V 36	
T99	294
5.69	
V 36	
T99	295
5.72	
V 36	
T99	296
5.80	
V 33 01.40.48	
T100	297
6.06	
V 30 01.41.16	
T101	298
6.23	
0.00	
V 30 01.41.37	
T102	299



0.36	
V 33 01.42.20	
T103 300	

0.53	
V 33	
T103 301	

0.64	
N 1' 01.42.50	
T104 302	

NÃO ERRE

0.64	
V 36 01.43.50	
T105 303	

0.78	
V 36	
T105 304	

0.87

V 33 01.44.13

T106 305



1.08

V 33

T106 306



1.17

V 33

T106 307



1.52

V 33

T106 308



1.60

V 33

T106 309



PELO TRILHO





DO GADO





1.69

V 33

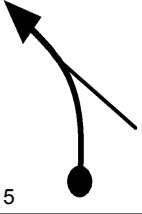
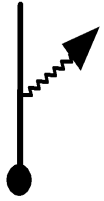
T106 310

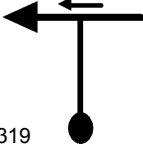

1.79	
N 2' 01.45.54	
T107	311
1.79	
V 36 01.47.54	
T108	312
1.81	
V 36	
T108	313
1.94	
V 36	
T108	314
2.03	
V 36	
T108	315
2.06	
V 33 01.48.21	
T109	316

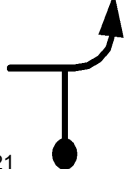
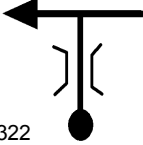
2.44	
V 33	
T109	317
2.45	
V 33	
T109	318
2.76	
V 36 01.49.37	
T110	319
2.80	
V 36	
T110	320
2.90	
V 30 01.49.51	
T111	321
3.09	
V 30	
T111	322

BAMP

3.14

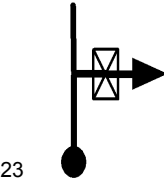

V 45 01.50.20

T112 323

COSTEAR CERCA

3.32

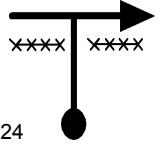

V 39 01.50.34

T113 324

COSTEAR MATO

3.44



V 39

T113 325

COSTEAR MATO

3.58

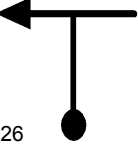

V 39

T113 326

COSTEAR MATO

3.80

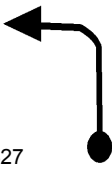

V 39

T113 327

COSTEAR CERCA

3.89

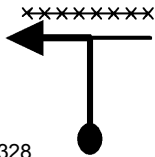

V 39

T113 328

3.97

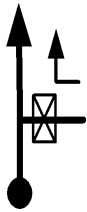

V 39

T113 329

COSTEAR MATO

4.09

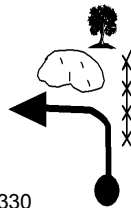

V 39

T113 330

4.23

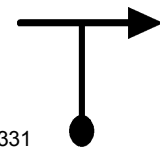

V 30 01.51.58

T114 331

4.27



N 2' 01.52.03

T115 332

4.27

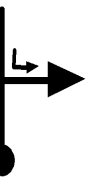

V 30 01.54.03

T116 333

4.55



N 30s 01.54.37

T117 334

ATENÇÃO

4.55

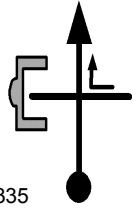

V 30 01.55.07

T118 335

4.59

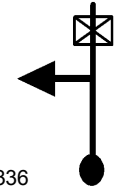

V 36 01.55.12

T119 336

5.06

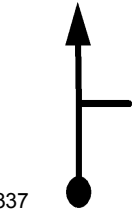

V 39 01.55.58

T120 337

COSTEAR BANANEIRA

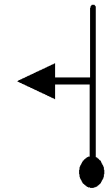

5.24



0.00

V 39 01.56.15

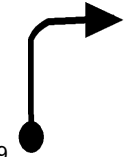
T121 338

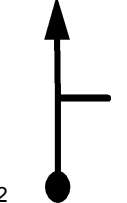
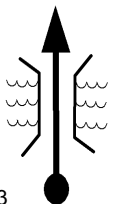
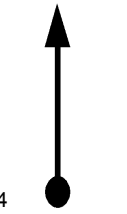
0.36	
V 39	
T121	339
0.40	
V 33 01.56.52	
T122	340
0.52	
V 33	
T122	341
0.70	
V 30 01.57.25	
T123	342
0.74	
V 33 01.57.30	
T124	343
COSTEAR MATO	
0.96	
V 33	
T124	344

NÃO ERRE

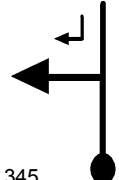
1.07	
V 30 01.58.06	
T125	

1.34	
NI'30s 01.58.38	
T126	

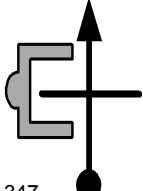
1.34	
V 30 02.00.08	
T127	

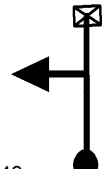
1.37	
V 36 02.00.12	
T128	

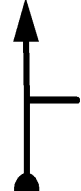
1.86	
V 39 02.01.01	
T129	

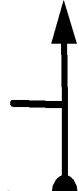
2.04	
V 39	
T129	

ENTRE NO MATO

2.10

V 39

T129 351



2.12

V 30 02.01.25

T130 352



2.44

V 33 02.02.03

T131 353

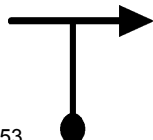

COSTEAR MATO

2.69

V 36 02.02.30

T132 354

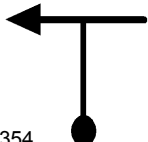

2.78

V 36

T132 355

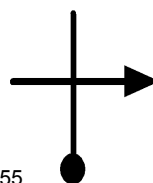

2.90

V 36

T132 356

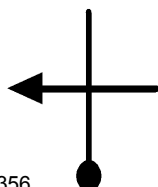

2.94



V 36

T132 357

CUIDADO DESCIDA

3.13



V 30 02.03.14



T133 358

SE PREPARA !!

3.39

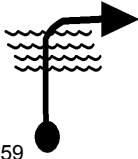

V 15 02.03.45

T134 359



3.42



V 15



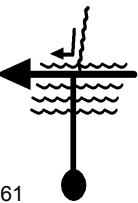

T134 360

3.44



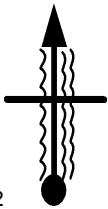

V 15

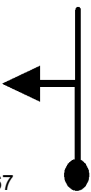
T134 361

3.52	
V 15	
T134	³⁶²
ARVORE	
POR BAIXO	
3.61	
V 15	
T134	³⁶³
3.63	
V 36 02.04.43	
T135	³⁶⁴
3.85	
V 15 02.05.05	
T136	³⁶⁵
3.94	
N 4' 02.05.27	
T137	³⁶⁶
3.94	
V 36 02.09.27	
T138	³⁶⁷

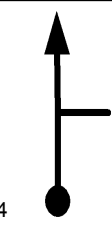
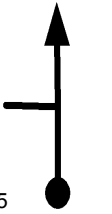
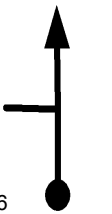
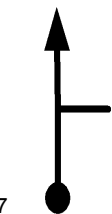
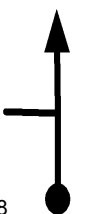
4.00	
V 36	
T138	368
4.04	
V 36	
T138	369
4.14	
V 30 02.09.47	
T139	370
4.33	
V 30	
T139	371
4.42	
V 30	
T139	372
4.46	
V 36 02.10.25	
T140	373

4.94	
V 39 02.11.13	
T141	374
5.12	
V 39	
T141	375
5.17	
V 39	
T141	376
5.19	
V 36 02.11.36	
T142	377
5.31	
V 36	
T142	378
5.42	
V 36	
T142	379

COSTEAR MATO

<h1>5.53</h1>	
V 36	
T142	

<h1>5.68</h1>	
V 36	
T142	

<h1>5.77</h1>	
V 36 02.12.34	
T143	

<h1>5.80</h1>	
V 45 02.12.37	
T144	

<h1>5.95</h1>	
V 45	
T144	

<h1>6.00</h1>	
V 30 02.12.53	
T145	

6.34	
NI'30s 02.13.34	
T146 386	

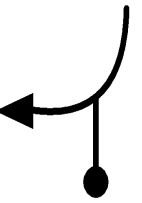
6.34	
0.00	
V 30 02.15.04	
T147 387	

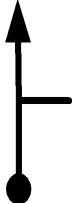
0.72	
V 30	
T147 388	

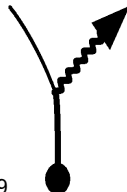
0.78	
V 36 02.16.37	
T148 389	

COSTEAR CALIPO

0.84	
V 36	
T148 390	

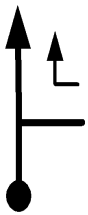
1.04	
V 36	
T148 391	

<h1>1.09</h1>	
V 36	
T148	<small>392</small>

<h1>1.15</h1>	
V 36	
T148	<small>393</small>

COSTEAR MATO

<h1>1.23</h1>	
V 36	
T148	<small>394</small>

<h1>1.33</h1>	
V 36	
T148	<small>395</small>

COSTEAR MATO

<h1>1.38</h1>	
V 36	
T148	<small>396</small>

<h1>1.47</h1>	
V 36	
T148	<small>397</small>

1.57	
V 36	
T148	398
COSTEAR BANANEIRA	
1.63	
V 36	
T148	399
1.70	
V 36	
T148	400
1.73	
V 36	
T148	401
1.81	
V 36	
T148	402
1.89	
V 36	
T148	403

BAMP

1.90

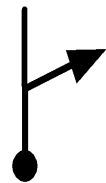

V 33 02.18.29

T149 404

1.96

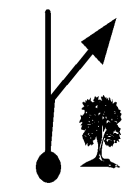

V 33

T149 405

BAMP

2.00



V 33

T149 406

ENTRE NO MATO

2.13



V 36 02.18.55

T150 407

2.39

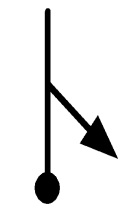

V 36



T150 408

2.64

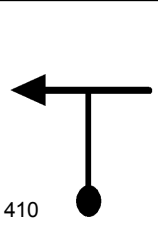

V 27 02.19.46

T151 409

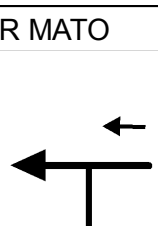
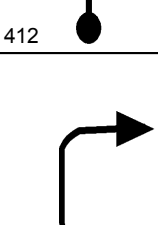
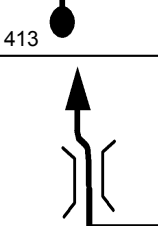
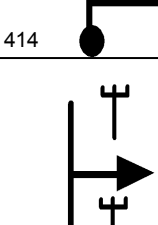
2.67	
V 36 02.19.50	
T152	410
2.79	
NI'30s 02.20.02	
T153	411
COSTEAR MATO	
2.79	
V 36 02.21.32	
T154	412
2.84	
V 36	
T154	413
2.93	
V 36	
T154	414
3.03	
V 36	
T154	415

3.09	
V 36	
T154	416

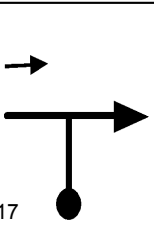
3.16	
V 36	
T154	417

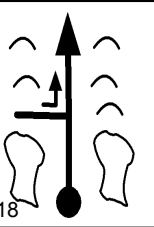
3.20	
V 36	
T154	418

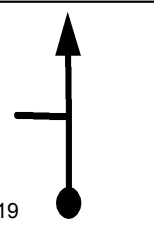
3.27	
V 36	
T154	419

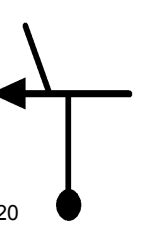

COSTEAR PARREIRA DE UVA

3.35	
V 36	
T154	420

CEPOS

3.42

V 36

T154⁴²¹



COSTEAR MATO

3.48

V 33 02.22.41

T155⁴²²

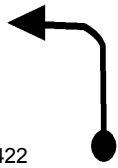

COSTEAR MATO

3.59

V 33

T155⁴²³

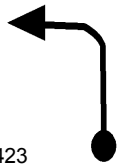

COSTEAR MATO

3.62

V 33

T155⁴²⁴







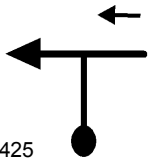

3.73

V 36 02.23.08

T156⁴²⁵

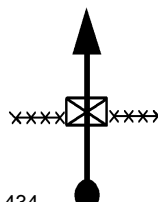

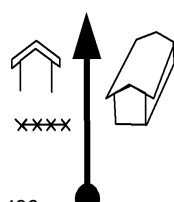
3.79	
V 36	
T156	426
3.87	
V 36	
T156	427
BAMP	
3.88	
V 33 02.23.23	
T157	428
BAMP	
3.94	
V 33	
T157	429
3.99	
V 33	
T157	430
ENTRE NO MATO	
4.12	
V 36 02.23.49	
T158	431

4.38	
V 27 02.24.15	
T159	432
4.59	
V 27	
T159	433
4.70	
V 21 02.24.58	
T160	434
4.73	
N 1' 02.25.03	
T161	435
4.73	
V 21 02.26.03	
T162	436
4.77	
V 21	
T162	437

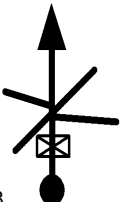
4.86	
V 33 02.26.25	
T163	438

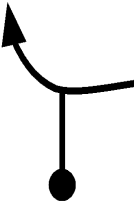
5.80	
0.00	
V 33 02.28.08	
T164	439

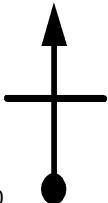
0.53	
V 33	
T164	440

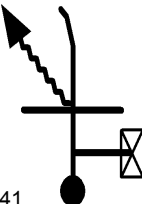
1.64	
V 36 02.31.07	
T165	441

COSTEAR MATO

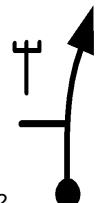
2.14	
V 36	
T165	442

COSTEAR MATO

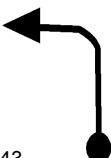
2.67	
V 36	
T165	443

2.77	
V 36	
T165	444
3.00	
V 36	
T165	445
3.07	
V 36	
T165	446
3.25	
V 36	
T165	447
3.70	
V 36	
T165	448
3.73	
V 27 02.34.36	
T166	449

3.78	
NI'30s 02.34.42	
T167	450

3.78	
V 27 02.36.12	
T168	451

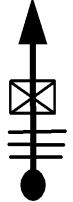

MATA BURRO

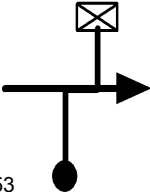
3.83	
V 33 02.36.19	
T169	452

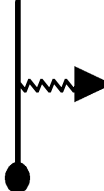

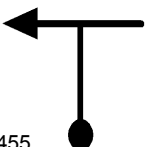
4.06	
V 30 02.36.44	
T170	453

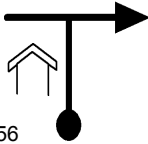
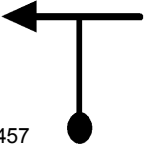
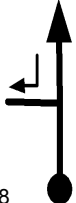

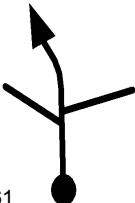
4.30	
V 33 02.37.13	
T171	454

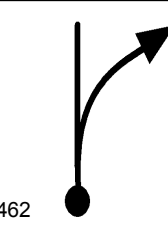
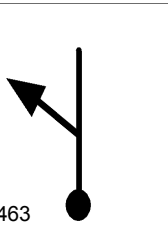
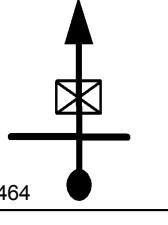
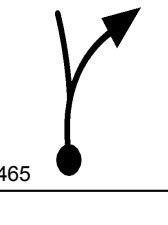
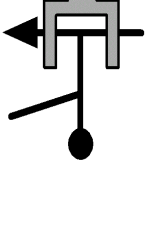
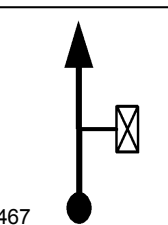
4.47	
V 33	
T171	455

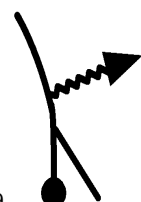
4.50	
V 30 02.37.35	
T172	456
4.64	
V 30	
T172	457
4.74	
V 30	
T172	458
4.83	
V 42 02.38.14	
T173	459
5.03	
V 42	
T173	460
5.69	
V 42	
T173	461

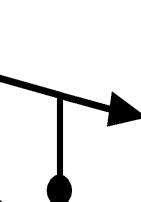
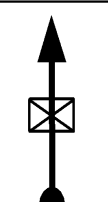
5.83	
V 42	
T173 462	
ENTRE NO CALIPAL	
5.89	
V 39 02.39.45	
T174 463	
5.91	
V 39	
T174 464	
6.17	
V 39	
T174 465	
6.39	
0.00	
V 33 02.40.31	
T175 466	
0.08	
V 33	
T175 467	

0.65	
V 33	
T175	468
0.70	
V 36 02.41.48	
T176	469
0.93	
V 36	
T176	470
0.99	
V 36	
T176	471
1.09	
V 36	
T176	472
1.21	
V 36	
T176	473

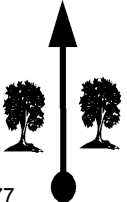
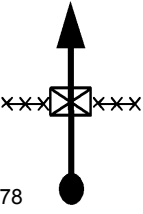
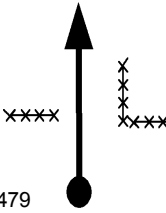
1.34	
V 36	
T176 ⁴⁷⁴	
BAMP	
1.47	
V 36	
T176 ⁴⁷⁵	
1.53	
V 36	
T176 ⁴⁷⁶	
1.57	
V 36	
T176 ⁴⁷⁷	
1.72	
V 36	
T176 ⁴⁷⁸	
COSTEAR CERCA	
1.87	
V 36	
T176 ⁴⁷⁹	



COSTEAR CERCA

1.95	
V 36	
T176 480	

2.02	
V 36	
T176 481	



BAMP

2.08	
V 36	
T176 482	

2.20	
V 33 02.44.18	
T177 483	

2.35	
V 33	
T177 484	

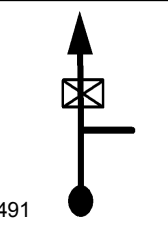
2.39	
V 33	
T177	485
BAMP	
2.44	
V 39 02.44.44	
T178	486
BAMP	
2.71	
V 39	
T178	487
BAMP	
2.78	
V 27 02.45.15	
T179	488
TRILHO DO GADO	
2.82	
V 30 02.45.20	
T180	489
COSTEAR CERCA	
2.89	
V 39 02.45.29	
T181	490

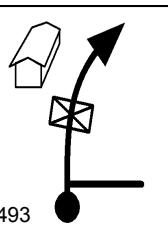
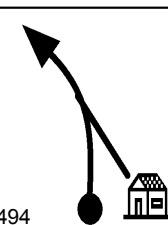
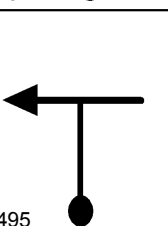
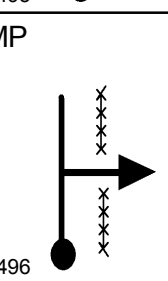
3.25	
V 36 02.46.02	
T182	491
3.42	
N 2' 02.46.19	
T183	492
3.42	
V 21 02.48.19	
T184	493
3.49	
V 21	
T184	494
3.58	
V 30 02.48.46	
T185	495
BAMP	
3.61	
V 36 02.48.50	
T186	496

3.71	
V 36	
T186	497
COSTEAR CERCA	
3.74	*****
V 36	
T186	498
BAMP	
3.95	
V 36	
T186	499
4.06	
V 33 02.49.35	
T187	500
PONTE PERIGOSA	
4.48	
V 33	
T187	501
4.58	
V 15 02.50.32	
T188	502

4.60

V 15

T188

503

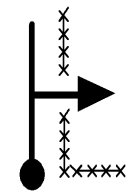

4.64

V 15 02.50.46

T188

504



FIM DE PROVA !!



www.t15.com.br

Tempo de Prova

MÉDIA A 02:50:46

FIM