

INICIO

MÉDIA A

MÉDIA B

MÉDIA C

6 ENDURO AMIGOS NA TRILHA
01 e 02 de Janeiro / 2015



IMPORTANTE

PLANILHA TERMICA
FITA ADESIVA DO LADO DE
TRÁS. NÃO USE CANETA
MARCA TEXTO,
USE CANETA ESFEROGRÁFICA
OU HIDROGRÁFICA

DIRETORES DE PROVA:
DIOGES OSELLAME
CLEBSON OSELLAME
REALIZAÇÃO: AMIGOS NA TRILHA
NOS TRECHOS URBANOS
PREVALECEM AS LEIS
DO CÓDIGO NACIONAL
DETRANSPITO. É OBRIGAÇÃO
RESPEITAR AS
PROPRIEDADES
ALHEIAS E OS MORADORES.
A ORGANIZAÇÃO NÃO SE
RESPONSABILIZA POR PASSAR
PROGRAMAÇÃO DE NAVEGAÇÃO.
É OBRIGAÇÃO DO PILOTO
CONFERIR A PROGRAMAÇÃO DO
NAVEGADOR.
LARGADA - 14:00 HS
CTG TIO MILLO
NEUTRO PRINCIPAL
LOCAL DA LARGADA
CHEGADA NO MESMO
LOCAL DA LARGADA
1 ETAPA KM
2 ETAPA KM
TOTAL KM
LEVANTAMENTO DA PROVA
COM MOTO CRF 230 COM
PNEU DIANTEIRO NOVO
E 12 LIBRAS

CUIDADO

ATENÇÃO

MUITA ATENÇÃO



Tempo de Prova

MÉDIA A 02:50:46

MÉDIA B 02:54:47

MÉDIA C 03:00:02



AFERIÇÃO

AFERIR

0.00		1	AFER
0.24		2	AFER
0.35		3	AFER
0.37		4	AFER
LOMBADA			
0.63		5	AFER

1.46

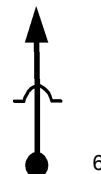

AFER

1.76

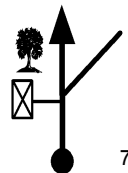

AFER

AFERIR!!

2.220

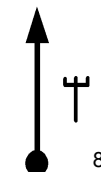

AFER

0.000



INÍCIO DE PROVA

BOA SORTE!!

0.00		25	00.00.00
		25	00.00.00
		25	00.00.00
		V	T1
0.24		25	
		25	
		25	
		V	T1
0.41		25	
		25	
		25	
		V	T1
0.54		25	
		25	
		25	
		V	T1
0.58		21	00.01.24
		21	00.01.24
		21	00.01.24
		V	T2

01 e 02 de Janeiro / 2015		Pág: 004	
0.74		21	
		21	
		21	
V	T2		
0.76		21	
		21	
		21	
V	T2		
0.78		21	
		21	
		21	
V	T2		
por baixo da casinha			
0.91		21	
		21	
		21	
V	T2		
0.94		21	
		21	
		21	
V	T2		
costear cerca			
0.95		21 00.02.27	
		18 00.02.27	
		15 00.02.27	
V	T3		
0.99		21	
		18	
		15	
V	T3		
bamp			
1.01		21	
		18	
		15	
V	T3		
1.03		36 00.02.41	
		33 00.02.43	
		30 00.02.46	
V	T4		
1.05		36	
		33	
		30	
V	T4		

01 e 02 de Janeiro / 2015		Pág: 005	
PONTE!!			
1.14		36	
		33	
		30	
V	T4		
BAMP			
1.58		36	
		33	
		30	
V	T4		
COSTEAR MATO!!			
1.67		36	
		33	
		30	
V	T4		
COSTEAR MATO!!			
1.85		36	
		33	
		30	
V	T4		
COSTEAR MATO!!			
1.96		36	
		33	
		30	
V	T4		
2.20		36	
		33	
		30	
V	T4		
BAMP			
2.24		36	
		33	
		30	
V	T4		
BAMP			
2.26		36	
		33	
		30	
V	T4		
2.31		33 00.04.49	
		30 00.05.03	
		27 00.05.20	
V	T5		

01 e 02 de Janeiro / 2015		Pág: 006	
VALO			
2.34		33	
		30	
		27	
V	T5		
VALO			
2.37		33	
		30	
		27	
V	T5		
VALO			
2.39		33	
		30	
		27	
V	T5		
2.43		33	
		30	
		27	
V	T5		
2.52		1'30s 00.05.12	
		1'30s 00.05.28	
		1' 00.05.48	
N	T6		
2.52		20 00.06.42	
		20 00.06.58	
		20 00.06.48	
0.00	V	T7	
0.04		20	
		20	
		20	
V	T7		
0.13		20	
		20	
		20	
V	T7		
0.18		20	
		20	
		20	
V	T7		
0.20		36 00.07.18	
		33 00.07.34	
		30 00.07.24	
V	T8		

COSTEAR CERCA

0.36		36	
		33	
		30	
		V	T8

COSTEAR CERCA

0.72		36	
		33	
		30	
		V	T8

0.83		36	
		33	
		30	
		V	T8

1.16		36	
		33	
		30	
		V	T8

COSTEAR CERCA

1.26		36	
		33	
		30	
		V	T8

1.61		33	00.09.39
		30	00.10.08
		27	00.10.13
		V	T9

PELO

TRILHO

DO

GADO!!

1.64		33	
		30	
		27	
		V	T9

1.68		33	
		30	
		27	
		V	T9

BAMP

1.70		33	
		30	
		27	
		V	T9

DENTRO DO RIO

1.74		39	00.09.53
		36	00.10.23
		33	00.10.30
		V	T10

1.80		39	
		36	
		33	
		V	T10

1.96		39	
		36	
		33	
		V	T10

2.06		33	00.10.22
		30	00.10.55
		27	00.11.05
		V	T11

2.12		33	
		30	
		27	
		V	T11

2.16		33	
		30	
		27	
		V	T11

2.31		36	00.10.50
		33	00.11.25
		30	00.11.38
		V	T12

2.46		36	
		33	
		30	
		V	T12



BAMP

2.52		36	
		33	
		30	
		V	T12

2.58		36	
		33	
		30	
		V	T12

2.61		36	
		33	
		30	
		V	T12

2.65		36	
		33	
		30	
		V	T12

2.71		36	
		33	
		30	
		V	T12

2.73		36	
		33	
		30	
		V	T12







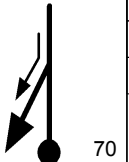
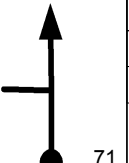
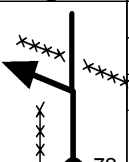
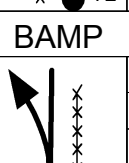
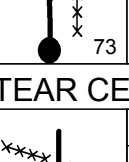
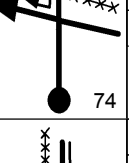
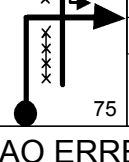
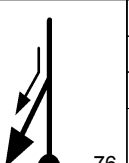
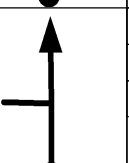

2.83		2'	00.11.42
		2'	00.12.22
		30s	00.12.41
		N	T13

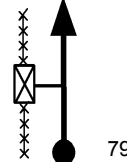

2.83		33	00.13.42
		30	00.14.22
		27	00.14.11
		V	T14

2.89		33	
		30	
		27	
		V	T14

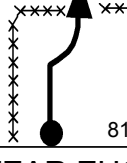
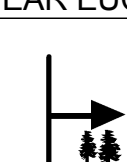
2.90		33	
		30	
		27	
		V	T14

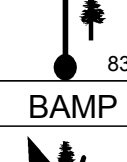
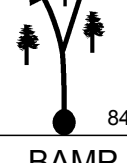
 NAO ERRE			
2.95		33	
		30	
		27	
		V	T14
3.01		36	00.14.01
		33	00.14.44
		30	00.14.35
		V	T15
3.09		36	
		33	
		30	
		V	T15
BAMP			
3.16		36	
		33	
		30	
		V	T15
COSTEAR CERCA			
3.26		36	
		33	
		30	
		V	T15
3.43		33	00.14.43
		30	00.15.29
		27	00.15.25
		V	T16
NAO ERRE			
3.49		33	
		30	
		27	
		V	T16
3.54		36	00.14.55
		33	00.15.43
		30	00.15.40
		V	T17
COSTEAR CERCA			
3.63		36	
		33	
		30	
		V	T17

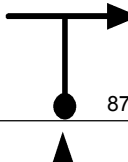
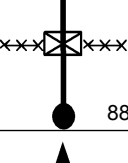
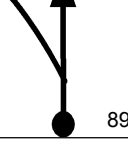
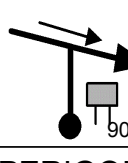

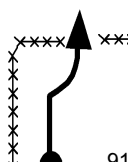
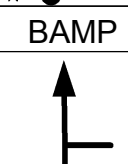
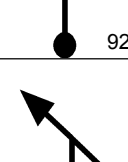
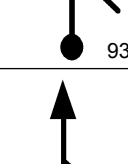
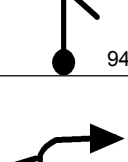
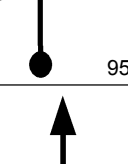

COSTEAR CERCA			
3.69		36	
		33	
		30	
		V	T17
COSTEAR CALIPO DA ESQUERDA			
3.78		36	
		33	
		30	
		V	T17
   ATENÇÃO			
3.92		36	
		33	
		30	
		V	T17
COESTEAR EUCALIPTO			
4.06		36	
		33	
		30	
		V	T17
CUIDADO CEPO			
4.11		30	00.15.52
		27	00.16.45
		24	00.16.48
		V	T18
BAMP			
4.18		30	
		27	
		24	
		V	T18
BAMP			
4.25		30	
		27	
		24	
		V	T18
BAMP			
4.30		30	
		27	
		24	
		V	T18



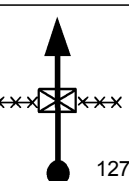
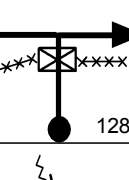
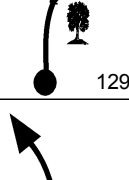

4.34		30	
		27	
		24	
		V	T18
4.37		30	
		27	
		24	
		V	T18
4.38		30	
		27	
		24	
		V	T18
4.47		36	00.16.35
		33	00.17.33
		30	00.17.42
		V	T19
  PERIGO!!			
4.54		36	
		33	
		30	
		V	T19
BAMP			
4.68		27	00.16.56
		24	00.17.56
		21	00.18.08
		V	T20
4.73		27	
		24	
		21	
		V	T20
4.79		27	
		24	
		21	
		V	T20
4.92		39	00.17.28
		36	00.18.32
		33	00.18.49
		V	T21
5.06		39	
		36	
		33	
		V	T21

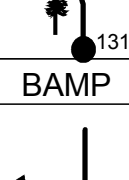
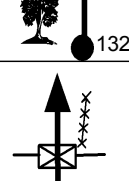
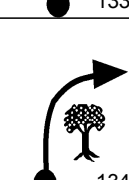



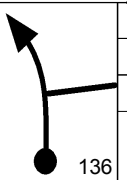
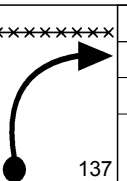
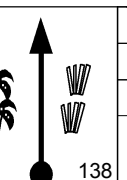

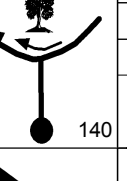
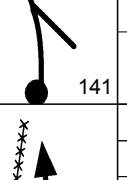
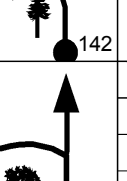
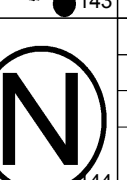
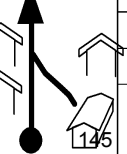
01 e 02 de Janeiro / 2015		Pág: 013	
5.18		39 36 33	V T21
5.30		39 36 33	V T21
5.61		2' 00.18.32 2' 00.19.41 2' 00.20.04	N T22
5.61 0.00		30 00.20.32 30 00.21.41 30 00.22.04	V T23
0.12		33 00.20.46 30 00.21.55 27 00.22.18	V T24
0.29		33 30 27	V T24
BURACO			
☠☠ PELA DIREITA			
0.31		33 30 27	V T24
0.35		39 00.21.12 36 00.22.23 33 00.22.49	V T25
0.66		1' 00.21.40 1' 00.22.54 1' 00.23.23	N T26
0.66		30 00.22.40 30 00.23.54 30 00.24.23	V T27



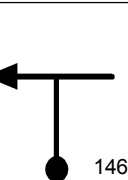
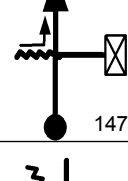
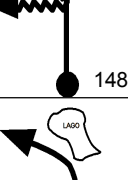
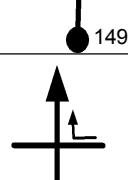

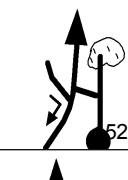
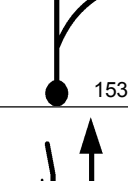

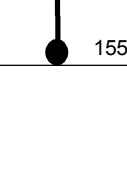
01 e 02 de Janeiro / 2015		Pág: 014	
0.78		30 30 30	V T27
1.08		33 00.23.31 30 00.24.44 27 00.25.13	V T28
1.31		33 30 27	V T28
POSTE TBG			
1.34		33 30 27	V T28
1.58		33 30 27	V T28
1.76		30 00.24.45 30 00.26.06 30 00.26.44	V T29
2.01		45 00.25.15 42 00.26.36 39 00.27.14	V T30
2.05		45 42 39	V T30
☠☠☠ EROSÕES			
2.27		33 00.25.36 30 00.26.58 27 00.27.38	V T31
2.51		36 00.26.02 33 00.27.27 30 00.28.10	V T32



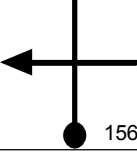

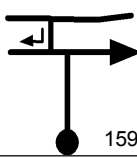
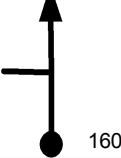

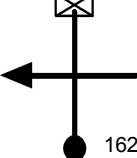
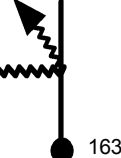
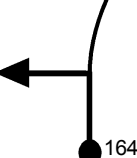
01 e 02 de Janeiro / 2015		Pág: 015	
BAMP			
2.64		36 33 30	V T32
2.71		36 33 30	V T32
2.82		36 33 30	V T32
2.87		39 00.26.38 36 00.28.06 33 00.28.53	V T33
3.14		39 36 33	V T33
3.16		39 36 33	V T33
3.21		39 36 33	V T33
3.26		39 36 33	V T33
☠ EROSÕES			
3.36		36 00.27.23 33 00.28.55 30 00.29.47	V T34



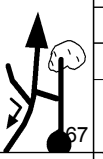
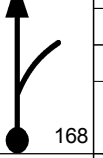

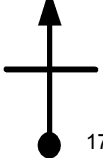

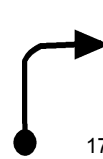
01 e 02 de Janeiro / 2015		Pág: 016	
3.42		36	
		33	
		30	
V T34			
BAMP			
3.54		36	
		33	
		30	
V T34			
3.63		36	
		33	
		30	
V T34			
3.77		39 00.28.04	
		36 00.29.40	
		33 00.30.36	
V T35			
4.04		39	
		36	
		33	
V T35			
COSTEAR CERCA			
4.25		33 00.28.48	
		30 00.30.28	
		27 00.31.28	
V T36			
BAMP			
4.43		36 00.29.08	
		33 00.30.49	
		30 00.31.52	
V T37			
4.52		36	
		33	
		30	
V T37			
4.63		36	
		33	
		30	
V T37			
4.77		36	
		33	
		30	
V T37			







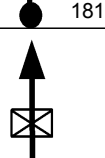
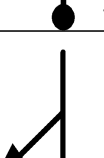

01 e 02 de Janeiro / 2015		Pág: 017	
4.99		36	
		33	
		30	
V T37			
COSTEAR CERCA			
5.04		36	
		33	
		30	
V T37			
BAMP			
5.10		27 00.30.15	
		24 00.32.02	
		21 00.33.13	
V T38			
5.20		2' 00.30.28	
		1'30s 00.32.17	
		1'30s 00.33.30	
N T39			
ATENÇÃO			
5.20		39 00.32.28	
		36 00.33.47	
		33 00.35.00	
V T40			
5.47		39	
		36	
		33	
V T40			
5.68		36 00.33.12	
		33 00.34.35	
		30 00.35.52	
V T41			
5.86		36	
		33	
		30	
V T41			
5.90		1' 00.33.34	
		1' 00.34.59	
		1' 00.36.18	
N T42			
5.90		27 00.34.34	
		27 00.35.59	
		27 00.37.18	
V T43			



01 e 02 de Janeiro / 2015		Pág: 018	
6.13		30 00.35.05	
		30 00.36.30	
		30 00.37.49	
0.00 V T44			
0.15		30	
		30	
		30	
V T44			
0.26		39 00.35.36	
		36 00.37.01	
		33 00.38.20	
V T45			
0.36		39	
		36	
		33	
V T45			
0.51		39	
		36	
		33	
V T45			
0.60		27 00.36.08	
		24 00.37.35	
		21 00.38.57	
V T46			
0.63		27	
		24	
		21	
V T46			
0.66		39 00.36.16	
		36 00.37.44	
		33 00.39.08	
V T47			
0.82		39	
		36	
		33	
V T47			
ESCOLHA!			
0.93		33 00.36.41	
		30 00.38.11	
		27 00.39.37	
V T48			





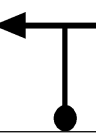
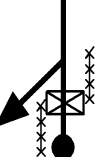

01 e 02 de Janeiro / 2015		Pág: 019	
0.96		39	00.36.44
		36	00.38.15
		33	00.39.41
		V	T49
1.25		39	
		36	
		33	
		V	T49
ATENÇÃO!!			
1.29		39	
		36	
		33	
		V	T49
ATENÇÃO!!			
1.48		39	
		36	
		33	
		V	T49
1.66		39	
		36	
		33	
		V	T49
1.89		1'30s	00.38.10
		1'30s	00.39.48
		1'30s	00.41.23
		N	T50
1.89		30	00.39.40
		30	00.41.18
		30	00.42.53
		V	T51
2.00		36	00.39.53
		33	00.41.31
		30	00.43.06
		V	T52
2.20		36	
		33	
		30	
		V	T52
ATENÇÃO			
2.35		39	00.40.28
		36	00.42.09
		33	00.43.48
		V	T53

01 e 02 de Janeiro / 2015		Pág: 020	
2.43		27	00.40.35
		24	00.42.17
		21	00.43.56
		V	T54
2.46		27	
		24	
		21	
		V	T54
2.50		39	00.40.45
		36	00.42.28
		33	00.44.08
		V	T55
2.67		39	
		36	
		33	
		V	T55
2.78		33	00.41.11
		30	00.42.56
		27	00.44.39
		V	T56
2.81		36	00.41.14
		33	00.42.59
		30	00.44.43
		V	T57
3.04		36	
		33	
		30	
		V	T57
3.15		36	
		33	
		30	
		V	T57
COSTEAR CERCA			
3.20		39	00.41.53
		36	00.43.42
		33	00.45.30
		V	T58
COSTEAR MATO			
3.25		39	
		36	
		33	
		V	T58

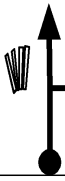
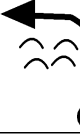

01 e 02 de Janeiro / 2015		Pág: 021	
3.43		33	00.42.14
		30	00.44.05
		27	00.45.55
		V	T59
3.50		33	
		30	
		27	
		V	T59
ACELERE!!			
3.64		33	
		30	
		27	
		V	T59
BAMP			
3.72		30	00.42.46
		27	00.44.40
		24	00.46.34
		V	T60
			
3.84		2'	00.43.00
		2'	00.44.56
		2'	00.46.52
		N	T61
NÃO ERRE			
3.84		39	00.45.00
		36	00.46.56
		33	00.48.52
		V	T62
4.03		39	
		36	
		33	
		V	T62
4.16		27	00.45.30
		24	00.47.28
		21	00.49.26
		V	T63

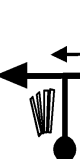
01 e 02 de Janeiro / 2015		Pág: 022	
NAO ERRE!			
☠☠ POSTE TBG			
4.27		36 00.45.44	V T64
		33 00.47.44	
		30 00.49.45	
4.50		36	V T64
		33	
		30	
		185	
4.54		36	V T64
		33	
		30	
		186	
ENTRE NO CALIPAL			
4.57		36	V T64
		33	
		30	
		187	
4.77		30 00.46.34	V T65
		30 00.48.39	
		30 00.50.45	
		188	
4.80		30	V T65
		30	
		30	
		189	
4.83		36 00.46.41	V T66
		33 00.48.46	
		30 00.50.52	
		190	
4.99		36	V T66
		33	
		30	
		191	
5.09		33 00.47.07	V T67
		30 00.49.14	
		27 00.51.24	
		192	
ATOLEIRO!			

01 e 02 de Janeiro / 2015		Pág: 023	
5.64		33	V T67
		30	
		27	
		193	
5.79		1' 00.48.24	V T68
		1' 00.50.38	
		1' 00.52.57	
		194	
5.79		30 00.49.24	V T69
		30 00.51.38	
		30 00.53.57	
		195	
0.23		30	V T69
		30	
		30	
		196	
0.32		30	V T69
		30	
		30	
		197	
0.64		36 00.50.41	V T70
		33 00.52.55	
		30 00.55.14	
		198	
☠☠ CUIDADO ESTRADA!			
0.79		36 00.50.56	V T71
		36 00.53.11	
		36 00.55.32	
		199	
1.29		36	V T71
		36	
		36	
		200	
2.00		36	V T71
		36	
		36	
		201	
2.15		45 00.53.12	V T72
		42 00.55.27	
		39 00.57.48	
		202	

01 e 02 de Janeiro / 2015		Pág: 024	
2.46		45	V T72
		42	
		39	
		203	
COSTEAR CALIPO			
2.56		45	V T72
		42	
		39	
		204	
COSTEAR ROÇA			
2.69		36 00.53.55	V T73
		33 00.56.14	
		30 00.58.38	
		205	
COSTEAR ROÇA			
2.73		36	V T73
		33	
		30	
		206	
2.75		36	V T73
		33	
		30	
		207	
2.95		36	V T73
		33	
		30	
		208	
3.02		45 00.54.28	V T74
		42 00.56.50	
		39 00.59.17	
		209	
COSTEAR CALIPO			
3.10		45	V T74
		42	
		39	
		210	
COSTEAR ROÇA			
3.23		36 00.54.45	V T75
		33 00.57.08	
		30 00.59.37	
		211	

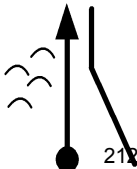
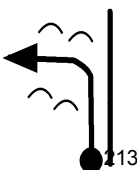
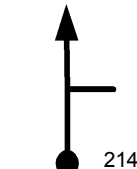
COSTEAR ROÇA



3.26		36	V	T75
		33		
		30		
		218		
3.29		36	V	T75
		33		
		30		
		213		
3.45		36	V	T75
		33		
		30		
		214		
3.48		33 00.55.10	V	T76
		30 00.57.35		
		27 01.00.07		
		215		

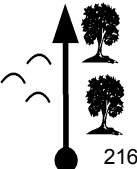

COSTEAR MATO



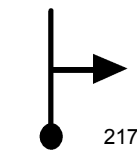

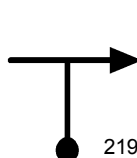
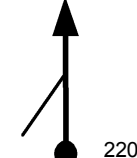
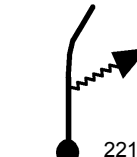
3.50		33	V	T76
		30		
		27		
		216		

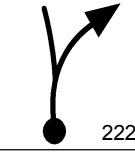
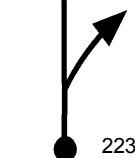

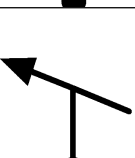
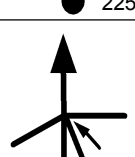
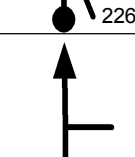
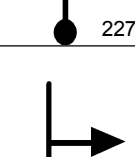
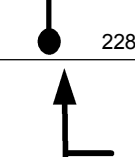
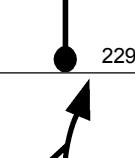
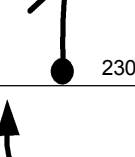
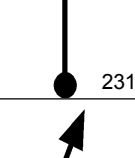
COSTEAR MATO

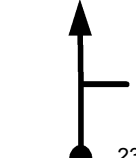
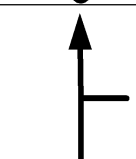

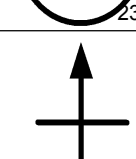
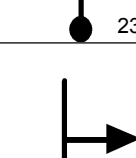
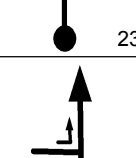
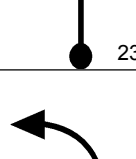

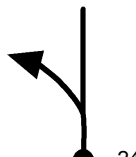
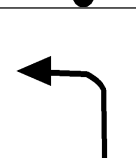
NA DIREITA!

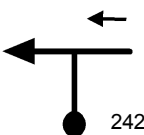
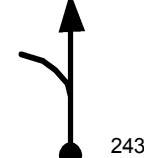

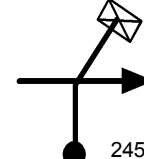
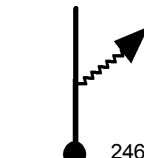
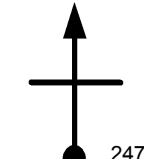
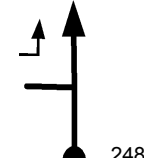
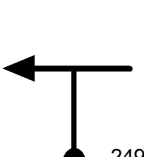
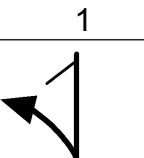
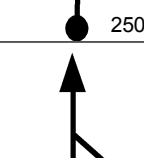

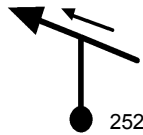
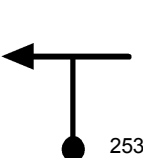
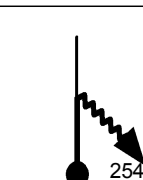
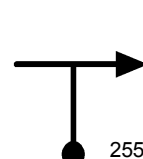
3.57		33	V	T76
		30		
		27		
		217		
3.68		2' 00.55.31	N	T77
		2' 00.57.59		
		1'30s 01.00.33		
		218		
3.68		30 00.57.31	V	T78
		30 00.59.59		
		30 01.02.03		
		219		
3.72		30	V	T78
		30		
		30		
		220		
4.09		36 00.58.21	V	T79
		33 01.00.48		
		30 01.02.53		
		221		

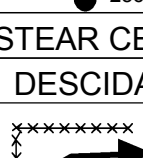
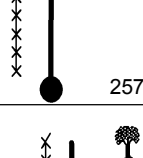
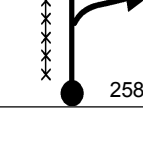
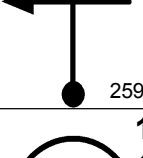

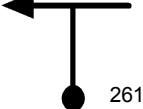
4.12		36	V	T79
		33		
		30		
		222		
4.14		36	V	T79
		33		
		30		
		223		
4.26		36	V	T79
		33		
		30		
		224		
4.33		36	V	T79
		33		
		30		
		225		
4.35		36	V	T79
		33		
		30		
		226		
4.38		36	V	T79
		33		
		30		
		227		
4.41		36	V	T79
		33		
		30		
		228		
4.49		36	V	T79
		33		
		30		
		229		
4.51		36	V	T79
		33		
		30		
		230		
4.59		36	V	T79
		33		
		30		
		231		
4.88		36	V	T79
		33		
		30		
		232		

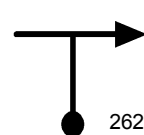
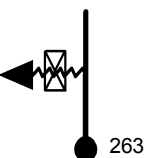
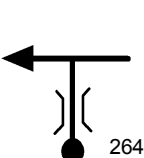

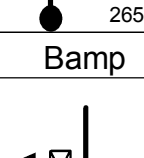
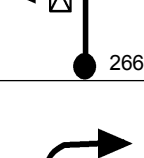

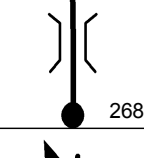
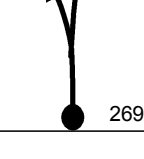
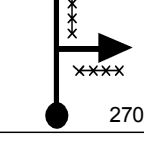

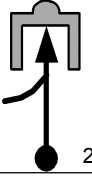
4.91		36	V	T79
		33		
		30		
		233		
4.94		36	V	T79
		33		
		30		
		234		
5.01		1'30s 00.59.53	N	T80
		1'30s 01.02.28		
		1'30s 01.04.43		
		235		
5.01		36 01.01.23	V	T81
		33 01.03.58		
		30 01.06.13		
		236		
5.04		36	V	T81
		33		
		30		
		237		
5.09		36	V	T81
		33		
		30		
		238		
5.18		36	V	T81
		33		
		30		
		239		
				
5.23		36	V	T81
		33		
		30		
		240		
5.33		36	V	T81
		33		
		30		
		241		

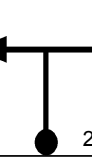
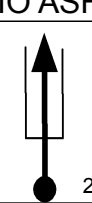
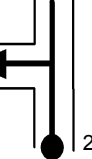
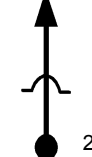
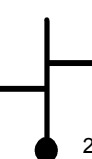
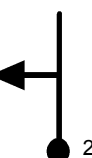
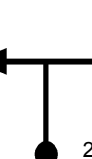

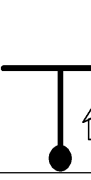

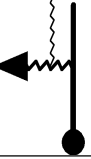
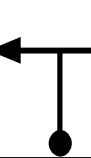

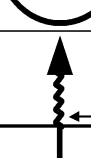

01 e 02 de Janeiro / 2015		Pág: 028	
5.40		36 33 30	V T81
5.54		36 33 30	V T81
☠☠☠TENCAO ABISMO			
5.58		36 33 30	V T81
5.73		30 01.02.35 30 01.05.17 30 01.07.39	V T82
5.75		36 01.02.37 33 01.05.19 30 01.07.42	V T83
5.83		36 33 30	V T83
5.88		36 33 30	V T83
5.94		36 33 30	V T83
1			
6.01		36 33 30	V T83
6.04		36 33 30	V T83







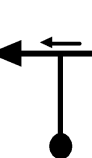
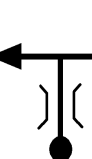

01 e 02 de Janeiro / 2015		Pág: 029	
6.09		36 33 30	V T83
6.14		36 33 30	V T83
ENTRE NO MATO			
6.25		33 01.03.27 30 01.06.14 27 01.08.42	V T84
6.41		33 30 27	V T84
COSTEAR MATO			
6.51		33 30 27	V T84
COSTEAR CERCA			
☠☠☠DESCIDA			
6.75		39 01.04.22 36 01.07.14 33 01.09.48	V T85
6.94		42 01.04.39 39 01.07.33 36 01.10.09	V T86
7.00		42 39 36	V T86
7.10		1'30s 01.04.53 1'30s 01.07.48 1'30s 01.10.25	N T87
7.10		36 01.06.23 36 01.09.18 36 01.11.55	V T88
0.00			V T88



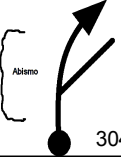



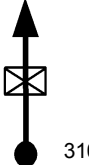

01 e 02 de Janeiro / 2015		Pág: 030	
0.70		36 36 36	V T88
1.24		39 01.08.27 36 01.11.22 33 01.13.59	V T89
1.32		39 36 33	V T89
COSTEAR CERCA			
1.36		39 36 33	V T89
Bamp			
1.57		39 36 33	V T89
1.67		36 01.09.06 33 01.12.05 30 01.14.46	V T90
☠☠☠ONTE PERIGOSA			
2.10		36 33 30	V T90
2.21		15 01.10.00 15 01.13.04 15 01.15.51	V T91
2.22		15 15 15	V T91
2.26		20' 01.10.12 18' 01.13.16 16' 01.16.03	N T92

01 e 02 de Janeiro / 2015		Pág: 031	
2.26 0.00		36 01.30.12 36 01.31.16 36 01.32.03	V T93
0.24		36 36 36	V T93
0.35		36 36 36	V T93
0.38		36 36 36	V T93
INICIO ASFALTO			
1.88		36 36 36	V T93
1.98		36 36 36	V T93
2.31		36 36 36	V T93
2.60		30 01.34.32 30 01.35.36 30 01.36.23	V T94
2.73		30 30 30	V T94
2.88		30 30 30	V T94

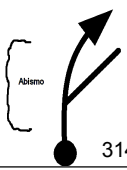



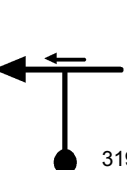

01 e 02 de Janeiro / 2015		Pág: 032	
2.99		36 01.35.19 36 01.36.22 36 01.37.10	V T95
3.35		36 36 36	V T95
3.57		36 36 36	V T95
3.84		45 01.36.44 42 01.37.47 39 01.38.35	V T96
4.33		45 42 39	V T96
4.46		36 01.37.34 33 01.38.41 30 01.39.32	V T97
☠☠☠ ATENÇÃO			
4.72		36 33 30	V T97
4.80		36 33 30	V T97
4.93		1' 01.38.21 1' 01.39.32 1' 01.40.28	N T98
4.93		36 01.39.21 33 01.40.32 30 01.41.28	V T99

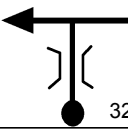
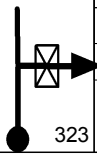
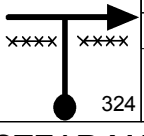
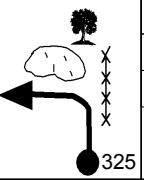
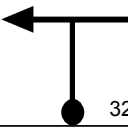
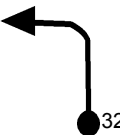
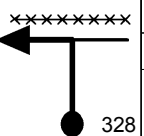
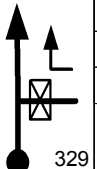
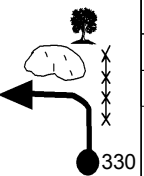

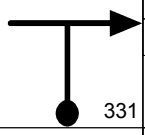
01 e 02 de Janeiro / 2015		Pág: 033	
5.23		36 33 30	V T99
5.45		36 33 30	V T99
5.60		36 33 30	V T99
5.69		36 33 30	V T99
5.72		36 33 30	V T99
5.80		33 01.40.48 30 01.42.07 27 01.43.13	V T100
6.06		30 01.41.16 30 01.42.38 30 01.43.47	V T101
6.23 0.00		30 01.41.37 30 01.42.58 30 01.44.08	V T102
			
0.36		33 01.42.20 30 01.43.42 27 01.44.51	V T103

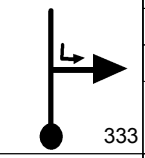

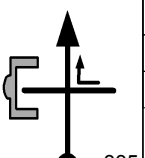
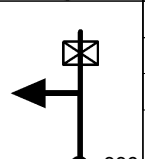
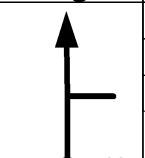

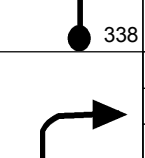
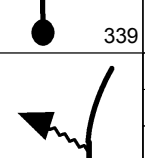

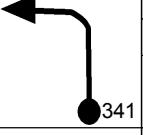
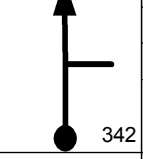
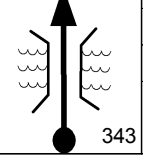
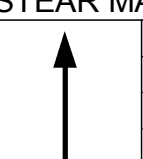
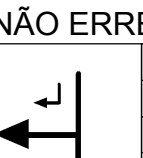
01 e 02 de Janeiro / 2015		Pág: 034	
0.53		33	
		30	
		27	
	V	T103	
0.64		1'	01.42.50
		1'	01.44.15
		1'	01.45.28
		N	T104
NÃO ERRE			
0.64		36	01.43.50
		33	01.45.15
		30	01.46.28
		V	T105
0.78		36	
		33	
		30	
		V	T105
0.87		33	01.44.13
		30	01.45.40
		27	01.46.56
		V	T106
1.08		33	
		30	
		27	
		V	T106
1.17		33	
		30	
		27	
		V	T106
1.52		33	
		30	
		27	
		V	T106
1.60		33	
		30	
		27	
		V	T106
PELO TRILHO			
DO GADO			
1.69		33	
		30	
		27	
		V	T106

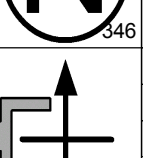
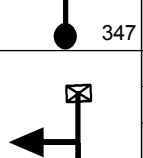
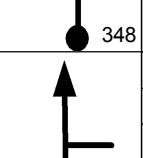
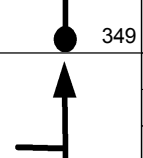

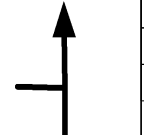
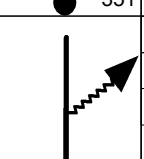
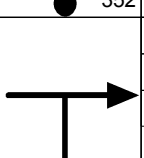
01 e 02 de Janeiro / 2015		Pág: 035	
1.79		2'	01.45.54
		2'	01.47.31
		2'	01.48.58
		N	T107
1.79		36	01.47.54
		33	01.49.31
		30	01.50.58
		V	T108
1.81		36	
		33	
		30	
		V	T108
1.94		36	
		33	
		30	
		V	T108
2.03		36	
		33	
		30	
		V	T108
2.06		33	01.48.21
		30	01.50.00
		27	01.51.31
		V	T109
2.44		33	
		30	
		27	
		V	T109
2.45		33	
		30	
		27	
		V	T109
2.76		36	01.49.37
		33	01.51.24
		30	01.53.04
		V	T110
2.80		36	
		33	
		30	
		V	T110
2.90		30	01.49.51
		30	01.51.39
		30	01.53.21
		V	T111

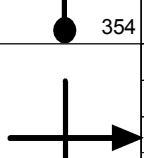
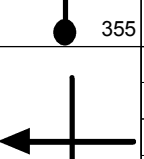
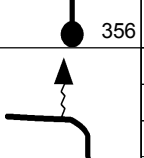

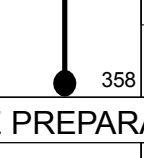
01 e 02 de Janeiro / 2015		Pág: 036	
3.09		30	
		30	
		30	
	V	T111	
BAMP			
3.14		45	01.50.20
		42	01.52.08
		39	01.53.50
		V	T112
COSTEAR CERCA			
3.32		39	01.50.34
		36	01.52.24
		33	01.54.06
		V	T113
COSTEAR MATO			
3.44		39	
		36	
		33	
		V	T113
COSTEAR MATO			
3.58		39	
		36	
		33	
		V	T113
COSTEAR MATO			
3.80		39	
		36	
		33	
		V	T113
COSTEAR CERCA			
3.89		39	
		36	
		33	
		V	T113
3.97		39	
		36	
		33	
		V	T113
COSTEAR MATO			
4.09		39	
		36	
		33	
		V	T113

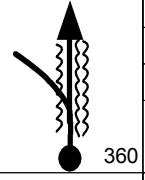
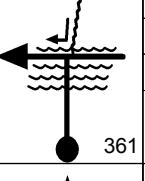
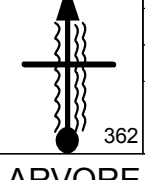

01 e 02 de Janeiro / 2015		Pág: 037	
4.23		30	01.51.58
		27	01.53.55
		24	01.55.46
		V	T114
4.27		2'	01.52.03
		2'	01.54.00
		2'	01.55.52
		N	T115
4.27		30	01.54.03
		30	01.56.00
		30	01.57.52
		V	T116
4.55		30s	01.54.37
		30s	01.56.34
		30s	01.58.25
		N	T117
ATENÇÃO			
4.55		30	01.55.07
		30	01.57.04
		30	01.58.55
		V	T118
4.59		36	01.55.12
		33	01.57.08
		30	01.59.00
		V	T119
5.06		39	01.55.58
		36	01.58.00
		33	01.59.56
		V	T120
COSTEAR BANANEIRA			
5.24 0.00		39	01.56.15
		36	01.58.18
		33	02.00.16
		V	T121
0.36		39	
		36	
		33	
		V	T121
0.40		33	01.56.52
		30	01.58.58
		27	02.01.00
		V	T122

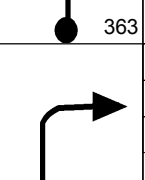
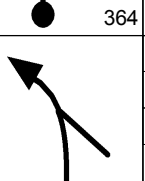
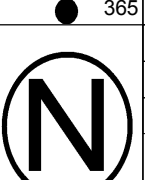
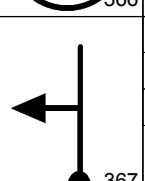
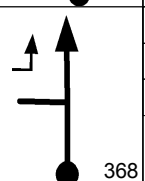
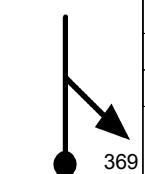
01 e 02 de Janeiro / 2015		Pág: 038	
0.52		33	
		30	
		27	
		V	T122
0.70		30	01.57.25
		27	01.59.34
		24	02.01.40
		V	T123
0.74		33	01.57.30
		30	01.59.39
		27	02.01.46
		V	T124
COSTEAR MATO			
0.96		33	
		30	
		27	
		V	T124
NÃO ERRE			
1.07		30	01.58.06
		30	02.00.19
		30	02.02.30
		V	T125
1.34		1'30s	01.58.38
		1'30s	02.00.51
		1'30s	02.03.02
		N	T126
1.34		30	02.00.08
		30	02.02.21
		30	02.04.32
		V	T127
1.37		36	02.00.12
		33	02.02.25
		30	02.04.36
		V	T128
1.86		39	02.01.01
		36	02.03.18
		33	02.05.35
		V	T129
2.04		39	
		36	
		33	
		V	T129

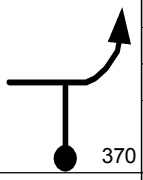
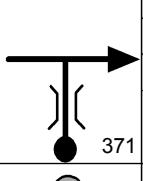
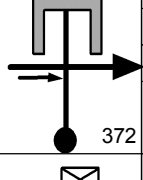
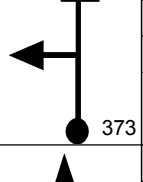
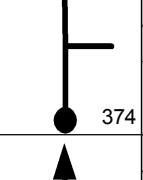
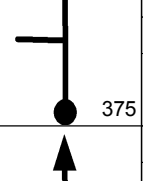
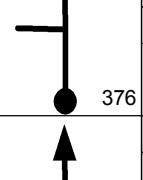
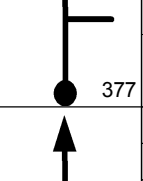
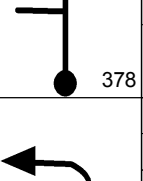
01 e 02 de Janeiro / 2015		Pág: 039	
ENTRE NO MATO			
2.10		39	
		36	
		33	
		V	T129
2.12		30	02.01.25
		27	02.03.44
		24	02.06.03
		V	T130
2.44		33	02.02.03
		30	02.04.27
		27	02.06.51
		V	T131
COSTEAR MATO			
2.69		36	02.02.30
		33	02.04.57
		30	02.07.24
		V	T132
2.78		36	
		33	
		30	
		V	T132
2.90		36	
		33	
		30	
		V	T132
2.94		36	
		33	
		30	
		V	T132
🦠🦠 CUIDADO DESCIDA			
3.13		30	02.03.14
		27	02.05.45
		24	02.08.17
		V	T133
SE PREPARA !!			
3.39		15	02.03.45
		12	02.06.19
		9	02.08.56
		V	T134
			

01 e 02 de Janeiro / 2015		Pág: 040	
3.42		15 12 9	V T134
3.44		15 12 9	V T134
3.52		15 12 9	V T134
ARVORE			
POR BAIXO			
3.61		15 12 9	V T134
3.63		36 02.04.43 33 02.07.31 30 02.10.32	V T135
3.85		15 02.05.05 12 02.07.55 9 02.10.58	V T136
3.94		4' 02.05.27 4' 02.08.22 4' 02.11.34	N T137
3.94		36 02.09.27 33 02.12.22 30 02.15.34	V T138
4.00		36 33 30	V T138
4.04		36 33 30	V T138

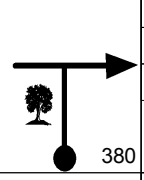
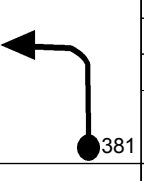
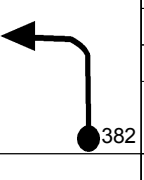
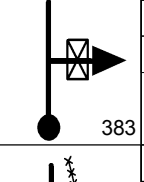
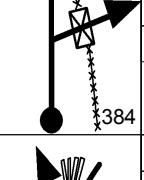
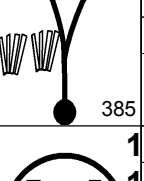
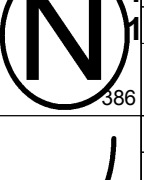
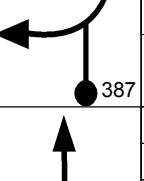
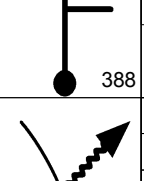
01 e 02 de Janeiro / 2015		Pág: 041	
4.14		30 02.09.47 30 02.12.44 30 02.15.58	V T139
4.33		30 30 30	V T139
4.42		30 30 30	V T139
4.46		36 02.10.25 33 02.13.22 30 02.16.37	V T140
4.94		39 02.11.13 36 02.14.15 33 02.17.34	V T141
5.12		39 36 33	V T141
5.17		39 36 33	V T141
5.19		36 02.11.36 33 02.14.40 30 02.18.02	V T142
5.31		36 33 30	V T142
5.42		36 33 30	V T142
COSTEAR MATO			

01 e 02 de Janeiro / 2015		Pág: 042	
5.53		36 33 30	V T142
5.68		36 33 30	V T142
5.77		36 02.12.34 33 02.15.43 27 02.19.11	V T143
5.80		45 02.12.37 42 02.15.46 39 02.19.15	V T144
5.95		45 42 39	V T144
6.00		30 02.12.53 30 02.16.04 30 02.19.34	V T145
6.34		1'30s 02.13.34 1'30s 02.16.44 1'30s 02.20.15	N T146
6.34		30 02.15.04 30 02.18.14 30 02.21.45	V T147
0.72		30 30 30	V T147
0.78		36 02.16.37 33 02.19.48 30 02.23.18	V T148
COSTEAR CALIPO			

0.84		36	V T148
		33	
		30	

1.04		36	V T148
		33	
		30	

1.09		36	V T148
		33	
		30	

1.15		36	V T148
		33	
		30	

COSTEAR MATO

1.23		36	V T148
		33	
		30	

1.33		36	V T148
		33	
		30	

COSTEAR MATO

1.38		36	V T148
		33	
		30	

1.47		36	V T148
		33	
		30	

1.57		36	V T148
		33	
		30	

COSTEAR BANANEIRA

1.63		36	V T148
		33	
		30	

1.70		36	V T148
		33	
		30	

1.73		36	V T148
		33	
		30	

1.81		36	V T148
		33	
		30	

1.89		36	V T148
		33	
		30	

BAMP

1.90		33 02.18.29	V T149
		30 02.21.50	
		27 02.25.33	

1.96		33	V T149
		30	
		27	

BAMP

2.00		33	V T149
		30	
		27	

ENTRE NO MATO

2.13		36 02.18.55	V T150
		33 02.22.18	
		30 02.26.03	

2.39		36	V T150
		33	
		30	

2.64		27 02.19.46	V T151
		24 02.23.13	
		21 02.27.04	

2.67		36 02.19.50	V T152
		33 02.23.18	
		30 02.27.10	

2.79		1'30 02.20.02	N T153
		1' 02.23.31	
		1' 02.27.24	

COSTEAR MATO

2.79		36 02.21.32	V T154
		33 02.24.31	
		30 02.28.24	

2.84		36	V T154
		33	
		30	

2.93		36	V T154
		33	
		30	

3.03		36	V T154
		33	
		30	

3.09		36	V T154
		33	
		30	

3.16		36	V T154
		33	
		30	

3.20		36	V T154
		33	
		30	

3.27		36	V T154
		33	
		30	



COSTEAR PARREIRA DE UVA

3.35		36	
		33	
		30	
		V	T154

CEPOS

3.42		36	
		33	
		30	
		V	T154

COSTEAR MATO

3.48		33	02.22.41
		30	02.25.46
		27	02.29.47
		V	T155

COSTEAR MATO

3.59		33	
		30	
		27	
		V	T155

COSTEAR MATO

3.62		33	
		30	
		27	
		V	T155

3.73		36	02.23.08
		33	02.26.16
		30	02.30.20
		V	T156

3.79		36	
		33	
		30	
		V	T156

3.87		36	
		33	
		30	
		V	T156

BAMP

3.88		33	02.23.23
		30	02.26.33
		27	02.30.38
		V	T157

BAMP

3.94		33	
		30	
		27	
		V	T157

3.99		33	
		30	
		27	
		V	T157

ENTRE NO MATO

4.12		36	02.23.49
		33	02.27.01
		30	02.31.10
		V	T158

4.38		27	02.24.15
		24	02.27.30
		21	02.31.41
		V	T159

4.59		27	
		24	
		21	
		V	T159

4.70		21	02.24.58
		21	02.28.18
		21	02.32.36
		V	T160

4.73		1'	02.25.03
		1'	02.28.23
		1'	02.32.41
		N	T161

4.73		21	02.26.03
		21	02.29.23
		21	02.33.41
		V	T162

4.77		21	
		21	
		21	
		V	T162

4.86		33	02.26.25
		33	02.29.45
		33	02.34.04
		V	T163

5.80 0.00		33	02.28.08
		33	02.31.28
		33	02.35.46
		V	T164

0.53		33	
		33	
		33	
		V	T164

1.64		36	02.31.07
		33	02.34.27
		30	02.38.45
		V	T165

COSTEAR MATO

2.14		36	
		33	
		30	
		V	T165

COSTEAR MATO







2.67		36	
		33	
		30	
		V	T165



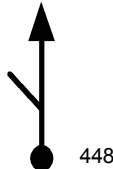
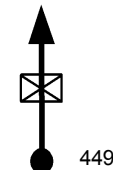

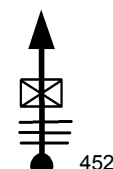
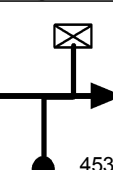
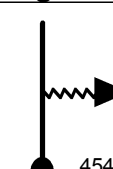

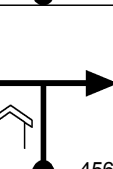
2.77		36	
		33	
		30	
		V	T165



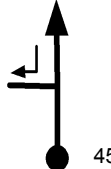

3.00		36	
		33	
		30	
		V	T165

3.07		36	
		33	
		30	
		V	T165

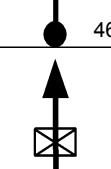
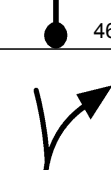
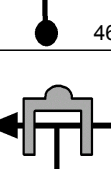
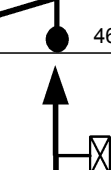
3.25		36	
		33	
		30	
		V	T165

01 e 02 de Janeiro / 2015		Pág: 049	
3.70		36 33 30	V T165
3.73		27 02.34.36 27 02.38.15 27 02.42.56	V T166
3.78		1' 30s 02.34.42 1' 02.38.21 1' 02.43.02	N T167
3.78		27 02.36.12 27 02.39.21 27 02.44.02	V T168
MATA BURRO			
3.83		33 02.36.19 33 02.39.28 33 02.44.09	V T169
4.06		30 02.36.44 30 02.39.53 30 02.44.34	V T170
4.30		33 02.37.13 30 02.40.22 27 02.45.03	V T171
4.47		33 30 27	V T171
4.50		30 02.37.35 30 02.40.46 30 02.45.30	V T172
4.64		30 30 30	V T172

01 e 02 de Janeiro / 2015		Pág: 050	
4.74		30 30 30	V T172
4.83		42 02.38.14 39 02.41.25 36 02.46.09	V T173
5.03		42 39 36	V T173
5.69		42 39 36	V T173
5.83		42 39 36	V T173
ENTRE NO CALIPAL			
5.89		39 02.39.45 36 02.43.03 33 02.47.55	V T174
5.91		39 36 33	V T174
6.17		39 36 33	V T174
6.39		33 02.40.31 33 02.43.53 33 02.48.50	V T175
0.00			
0.08		33 33 33	V T175

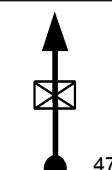
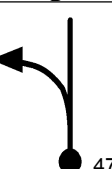
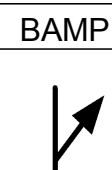
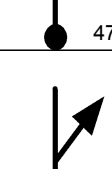
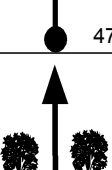
01 e 02 de Janeiro / 2015		Pág: 051	
0.65		33 33 33	V T175
0.70		36 02.41.48 33 02.45.10 30 02.50.06	V T176
0.93		36 33 30	V T176
0.99		36 33 30	V T176
1.09		36 33 30	V T176
1.21		36 33 30	V T176
1.34		36 33 30	V T176
BAMP			
1.47		36 33 30	V T176
1.53		36 33 30	V T176
1.57		36 33 30	V T176

1.72

36
33
30
V
T176

COSTEAR CERCA

1.87

36
33
30
V
T176



COSTEAR CERCA

1.95

36
33
30
V
T176

2.02

36
33
30
V
T176

BAMP

2.08

36
33
30
V
T176

2.20

33
30
27
V
T177

2.35

33
30
27
V
T177

2.39

33
30
27
V
T177

2.44

BAMP

39	02.44.44
36	02.48.22
33	02.53.38
V	T178

2.71

39
36
33
V
T178

2.78

BAMP

27	02.45.15
24	02.48.56
21	02.54.15
V	T179

TRILHO DO GADO

2.82

30	02.45.20
27	02.49.02
24	02.54.22
V	T180

COSTEAR CERCA

2.89

39	02.45.29
36	02.49.11
33	02.54.33
V	T181

3.25

36	02.46.02
33	02.49.47
30	02.55.12
V	T182

3.42

2'	02.46.19
2'	02.50.06
1'30s	02.55.32
N	T183

3.42

21	02.48.19
18	02.52.06
15	02.57.02
V	T184

3.49

21	
18	
15	
V	T184

3.58

30	02.48.46
30	02.52.38
30	02.57.41
V	T185

3.61

BAMP

36	02.48.50
33	02.52.41
30	02.57.44
V	T186

3.71

36
33
30
V
T186

COSTEAR CERCA

3.74

36
33
30
V
T186

BAMP

3.95

36
33
30
V
T186

4.06

33	02.49.35
30	02.53.31
27	02.58.38
V	T187

PONTE PERIGOSA

4.48

33
30
27
V
T187

4.58

15	02.50.32
15	02.54.33
15	02.59.48
V	T188

4.60

15
15
15
V
T188

4.64

15	02.50.46
15	02.54.47
15	03.00.02
V	T188

FIM DE PROVA !!



www.t15.com.br

Tempo de Prova

MÉDIA A 02:50:46

MÉDIA B 02:54:47

MÉDIA C 03:00:02

FIM